

Intrinsic universality and the computational power of self-assembly

Damien Woods



Caltech

Computation and geometry

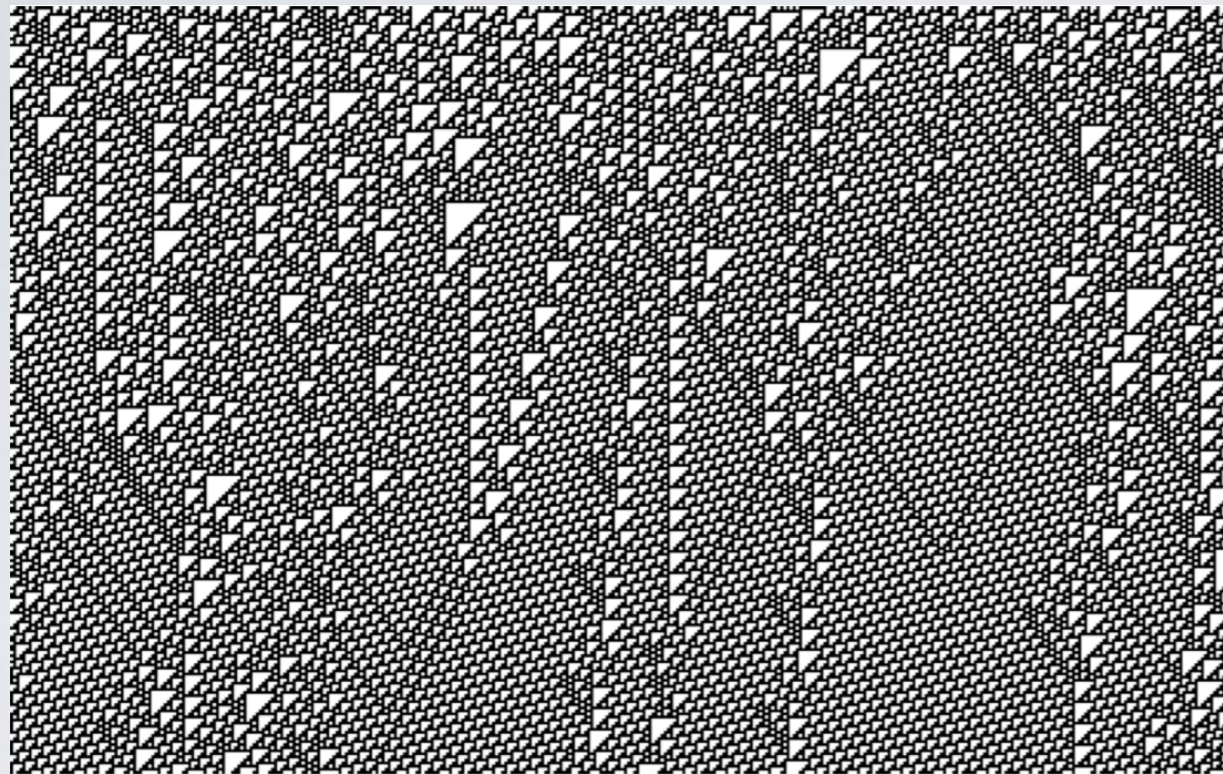

Rule 110 - from Cook. Complex Sys 2004.

Time

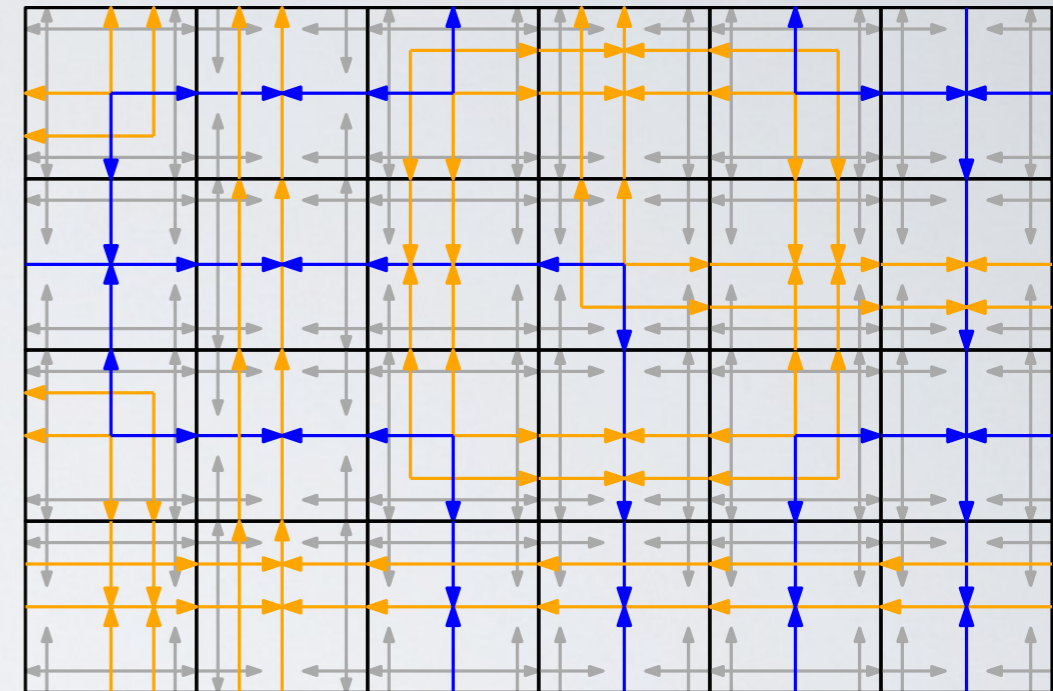

Rotatable Wang tiles
Portion of a tiling of Robinson's
10-tile aperiodic square tile set

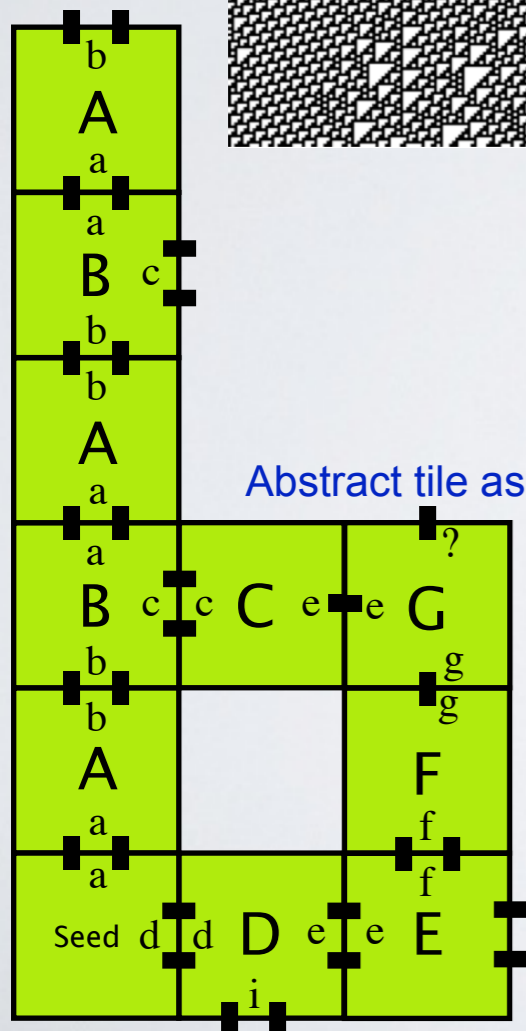

Abstract tile assembly model.
Winfree 1998

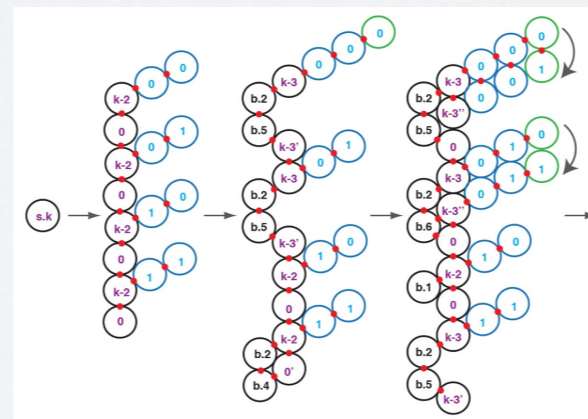

Nubots - From Woods, Chen, Goodfriend, Dabby, Winfree, Yin. ITCS 2013

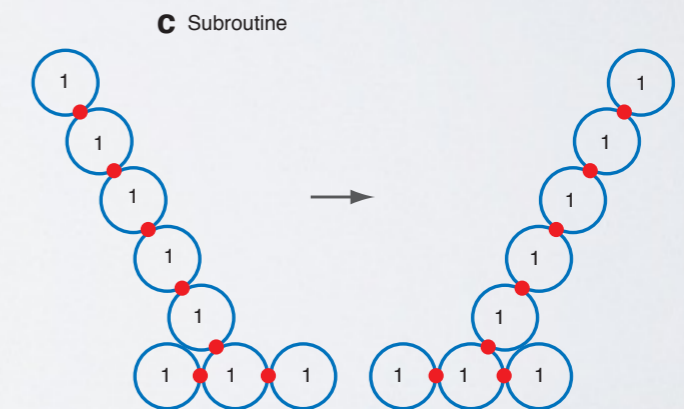

Nature as engineer

- Biological organisms *organise matter*
 - Structure and dynamics

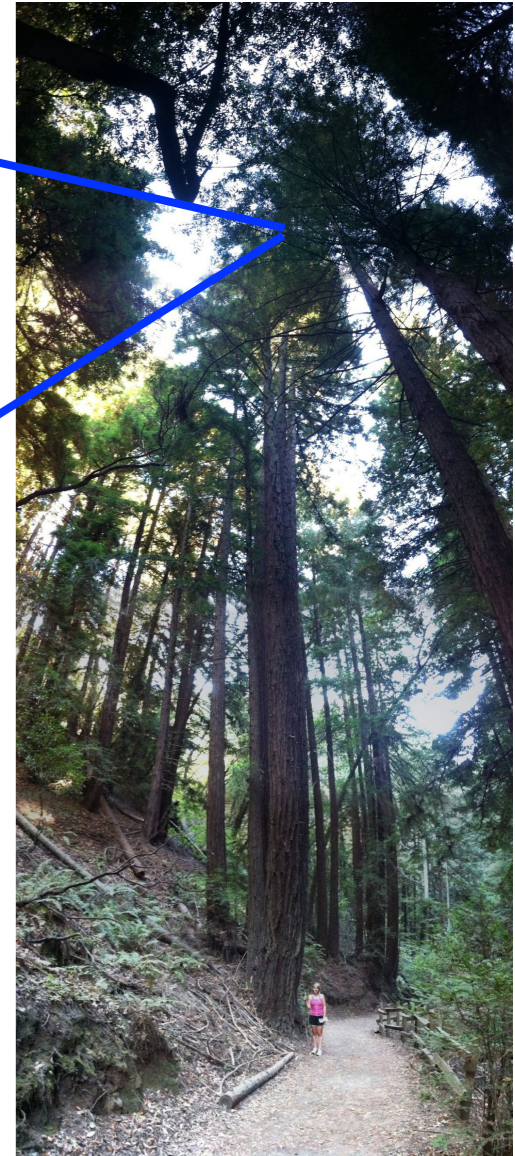
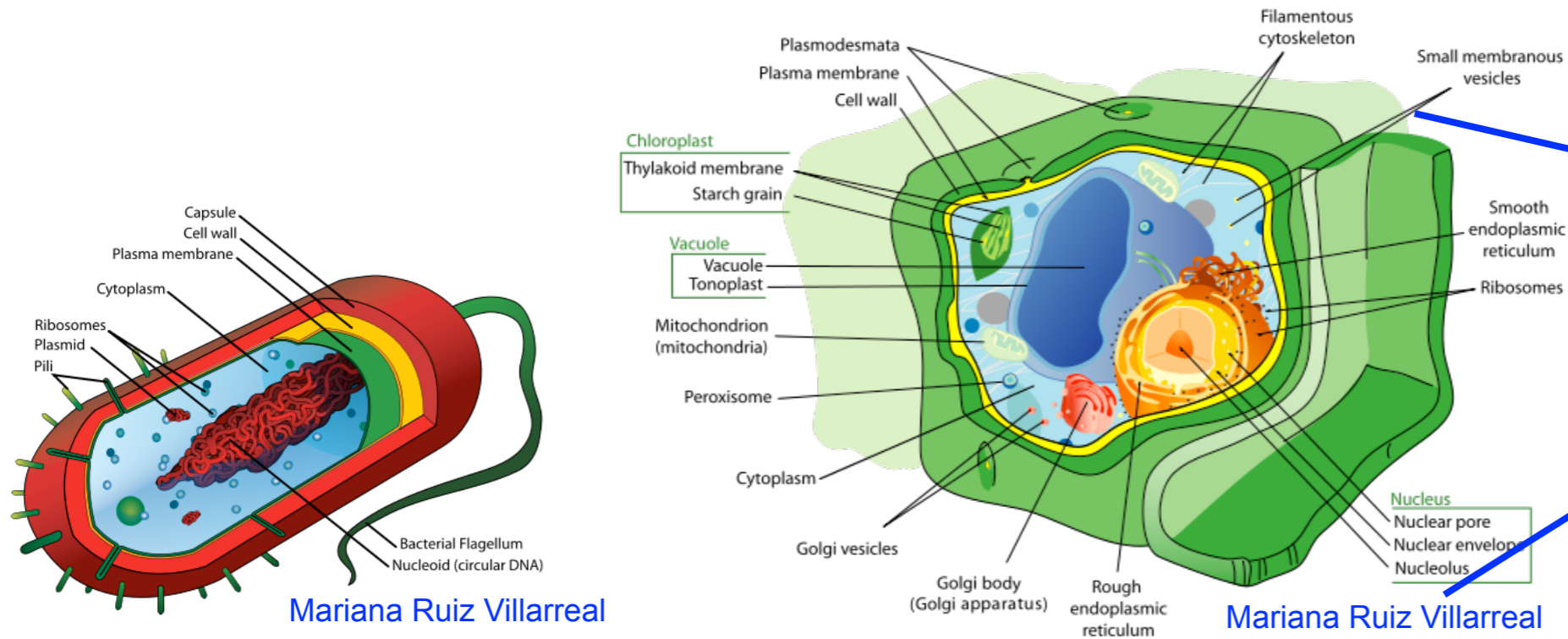

- Synthetic biologists would like to design and build artificial versions of such systems
 - with this level of complexity
 - and at the nanometer scale
- Or, we could build it from the ground up... but can we cope with the complexity?

Computers

- How have computer scientists and engineers managed to build systems with so many components and interactions that no one person can understand everything?
- Abstraction
- Clear understanding at each level

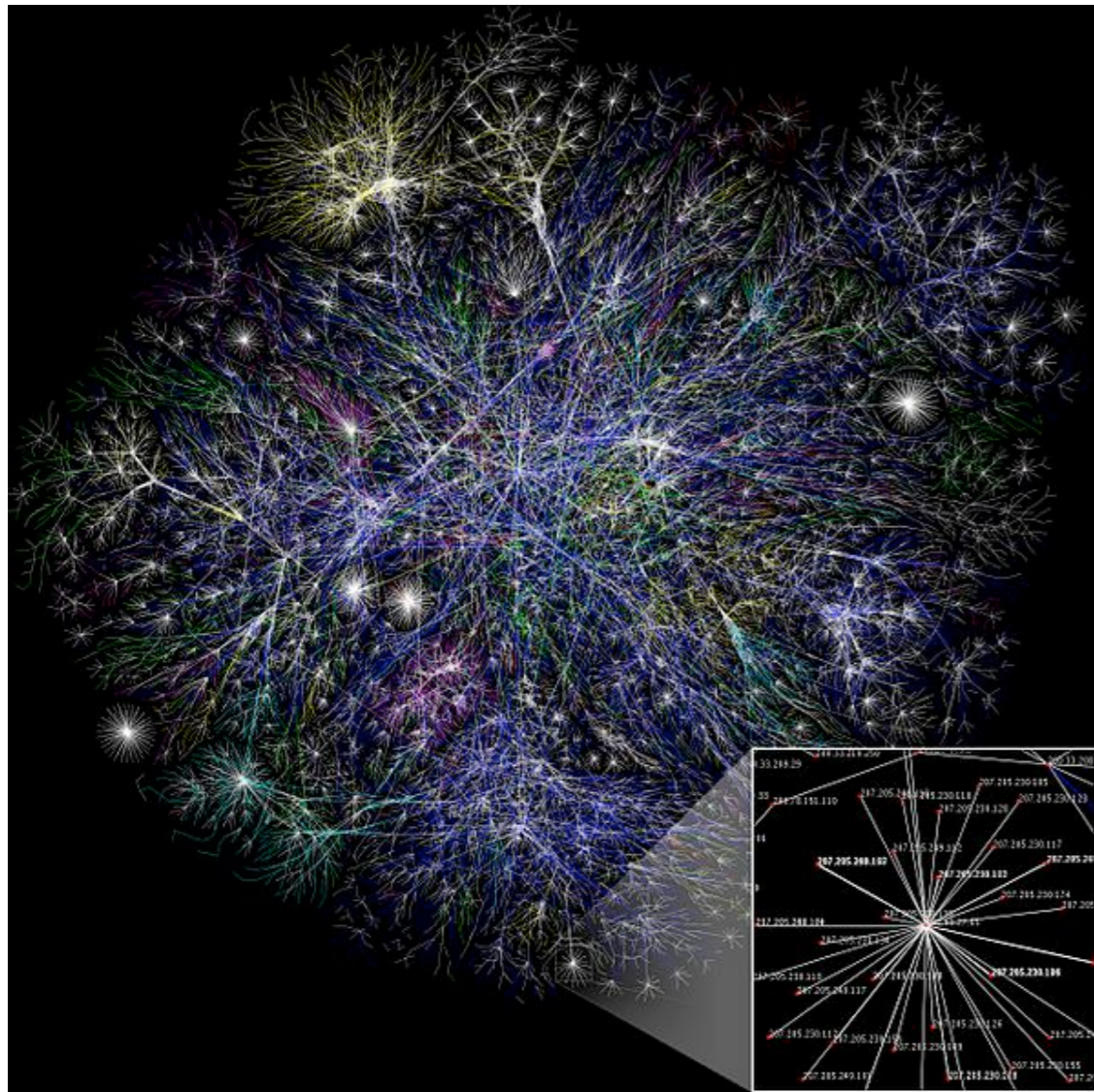

Map of 30% of the Internet. 2005. The Opte Project.

Microprocessor Transistor Counts 1971-2011 & Moore's Law

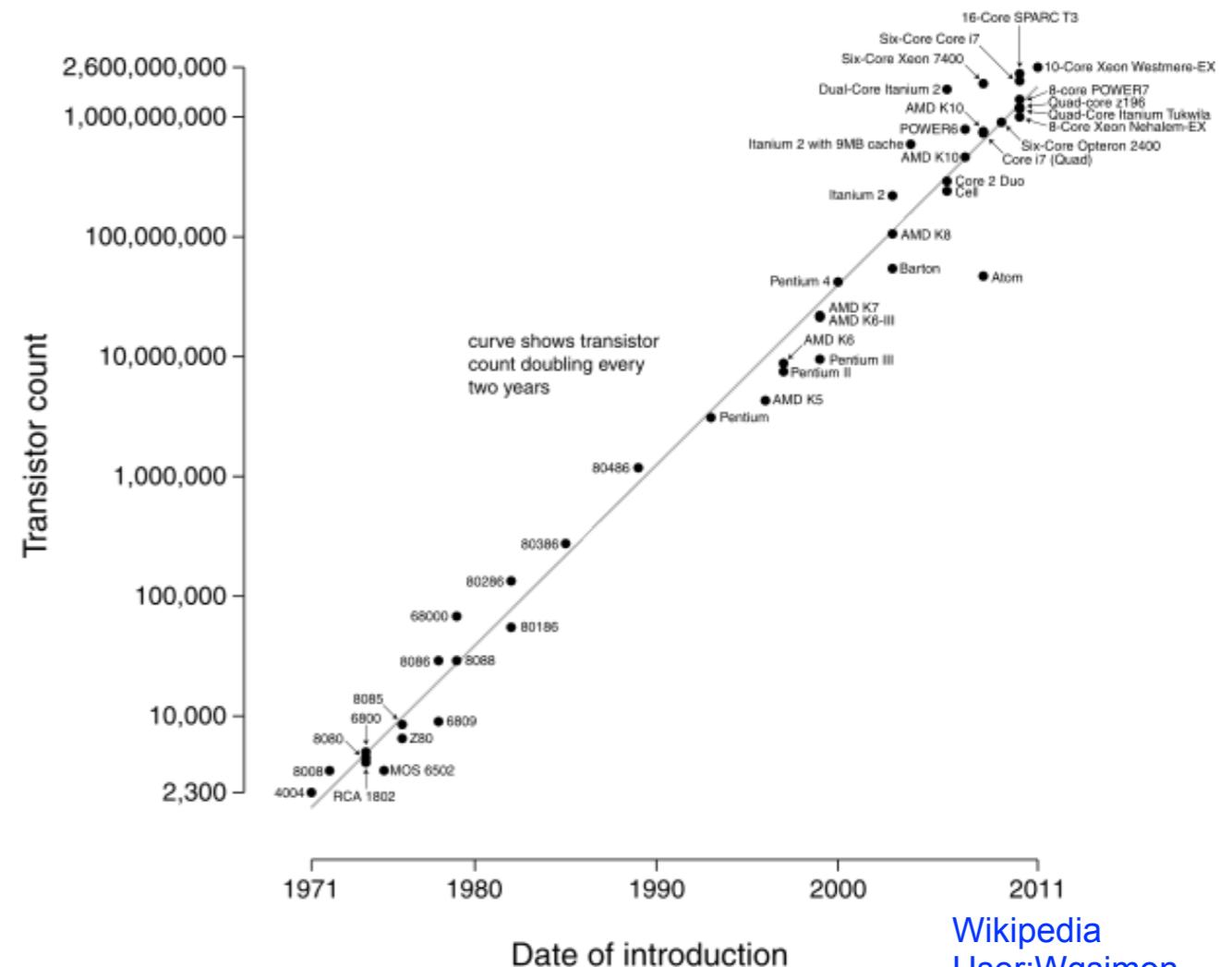

Wikipedia
User:Wgsimon

DNA

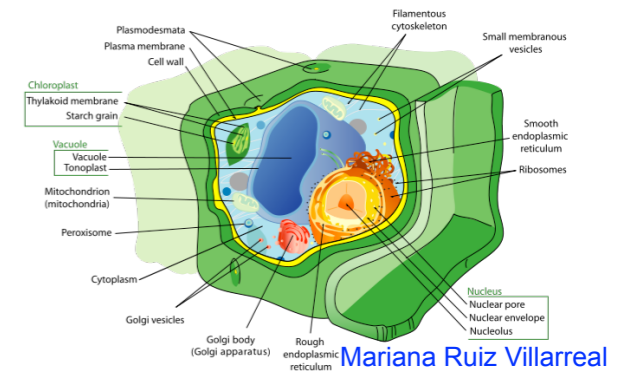

- Organisms use their DNA sequence to encode both:
 - structure (instructions on how to build an organism) and
 - dynamics (instructions on how to run an organism)
- Analogous to Biology, but in a MUCH simpler fashion, we can encode our engineering intentions into DNA
 - structure (use sequence information & base-pairing)
 - dynamics (use sequence information, base-pairing & competitive binding)

Complexity of DNA based systems: number of DNA nucleotides

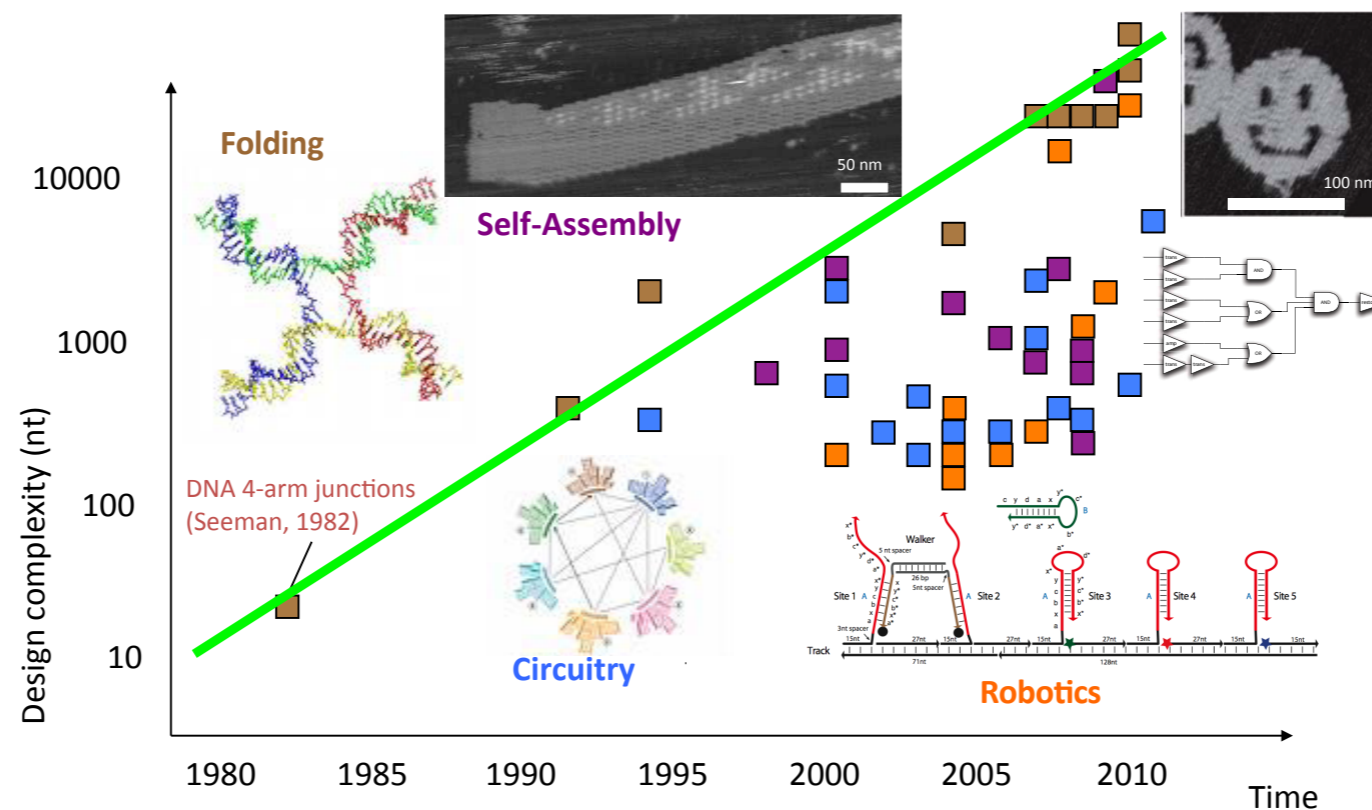

Things are getting complicated!

DNA tile-self assembly



- Genomic DNA: typically a wound-up ball of (double-helical) string
- Ned Seeman had the idea that DNA could be nicked, branched and tied in knots to make small structures called *tiles* ...

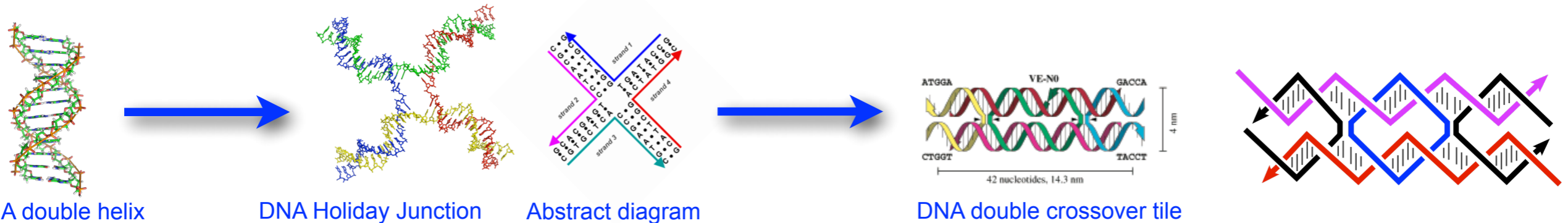

- ...which in turn would stick together forming 2D and 3D periodic arrays
 - Ability to “pattern matter”
 - Ned’s application: protein crystallography

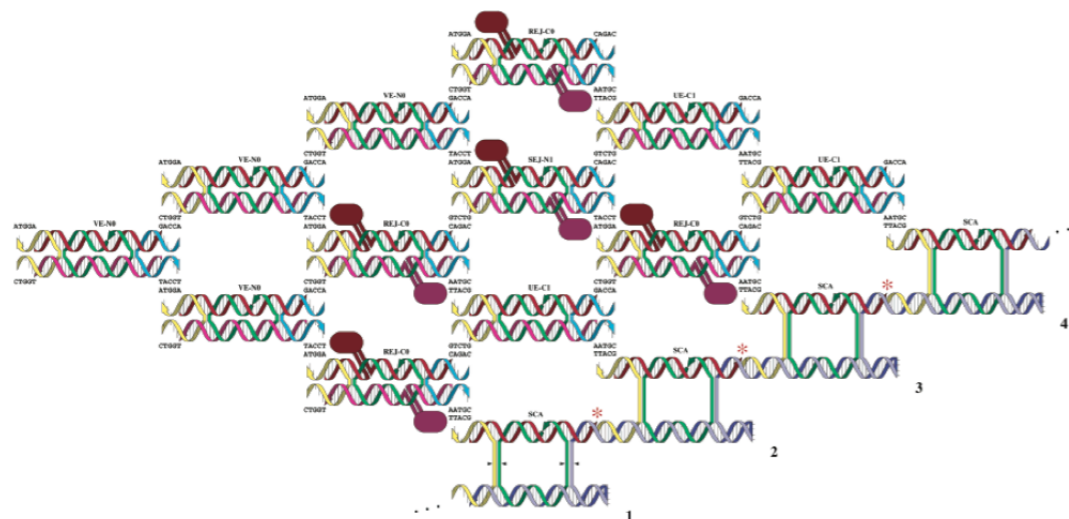

Barish, Rothemund, Winfree 2005

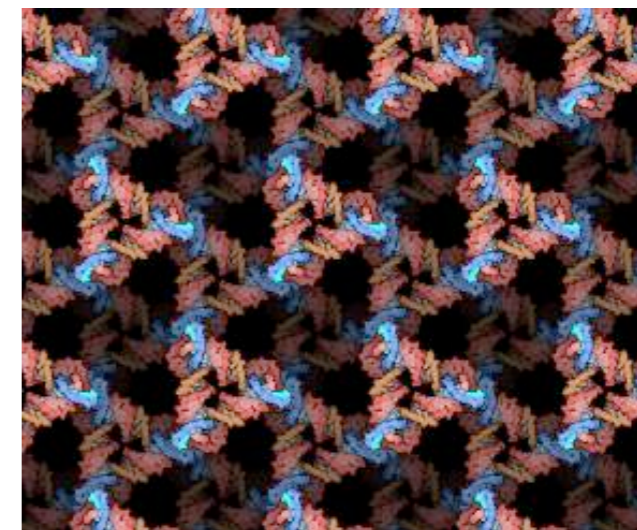

Artist rendering of 3D DNA crystal array made from DNA tensegrity triangles from Seeman lab. Zheng et al. Nature 2009





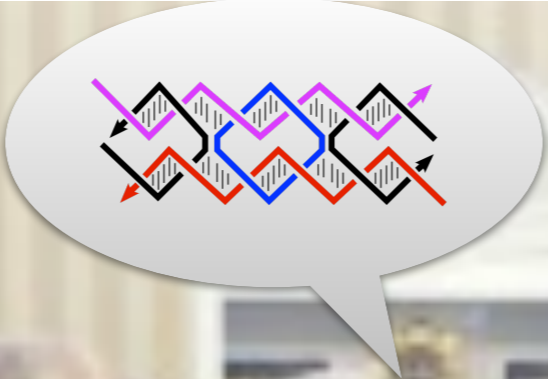

Algorithmic DNA tile assembly pipeline

- 1. High-level logical design using abstract Tile Assembly Model
- 2. Choose strength of sticky end strengths using kinetic Tile Assembly Model
 - Desired: strong enough sticky ends so that correct tiles stick, but weak enough so that wrong tiles quickly fall off
- 3. DNA sequence design
 - Choose DNA sequences for the sticky ends, getting the right strength
 - Choose DNA sequences for the tile core (easier---no dynamics here)
- 4. Synthesize & purify DNA strands (easy, pay a synthesis company a few quid per strand)
- 5. Mix with water & ionic buffer, heat to 90C, cool slowly enough (and/or temperature hold)
- 6. Image:
 - Atomic force microscopy (fine scale)
 - Fluorescence microscopy (large scale)

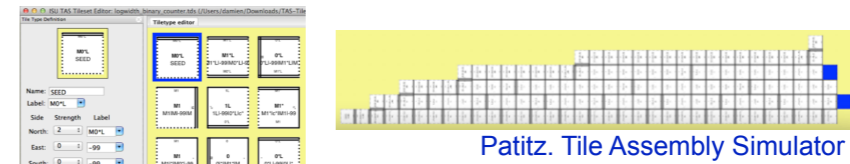

Logical design and simulation

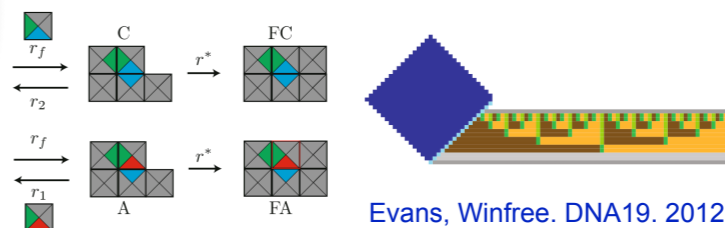

Simulation of kinetics of tile binding and unbinding (a crystal growth process)

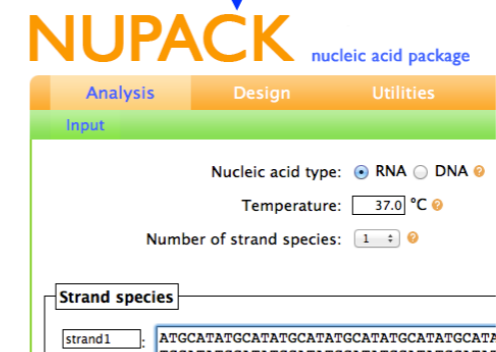

Sequence design informed by thermodynamic parameters of DNA base interactions. Other sequence design tools will also be used depending on the goal.

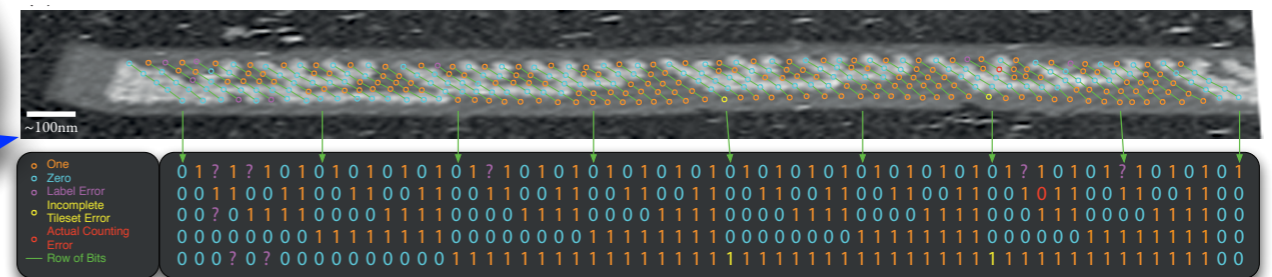

Constantine Evans. PhD Thesis. Caltech. 2014. Winfree group

Algorithmic DNA tile assembly pipeline

- 1. High-level logical design using abstract Tile Assembly Model
- 2. Choose strength of sticky end strengths using kinetic Tile Assembly Model
 - Desired: strong enough sticky ends so that correct tiles stick, but weak enough so that wrong tiles quickly fall off
- 3. DNA sequence design
 - Choose DNA sequences for the sticky ends, getting the right strength
 - Choose DNA sequences for the tile core (easier---no dynamics here)
- 4. Synthesize & purify DNA strands (easy, pay a synthesis company a few quid per strand)
- 5. Mix with water & ionic buffer, heat to 90C, cool slowly enough (and/or temperature hold)
- 6. Image:
 - Atomic force microscopy (fine scale)
 - Fluorescence microscopy (large scale)

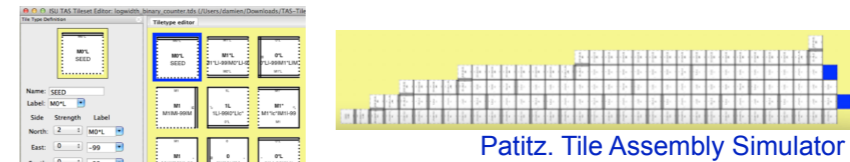

Logical design and simulation

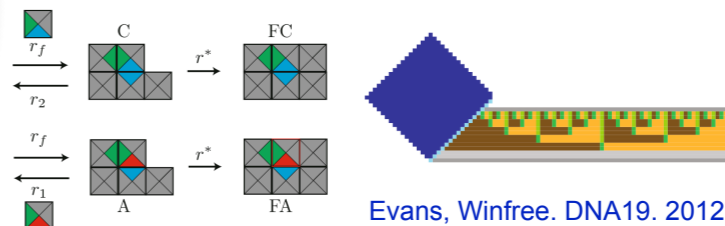

Simulation of kinetics of tile binding and unbinding (a crystal growth process)

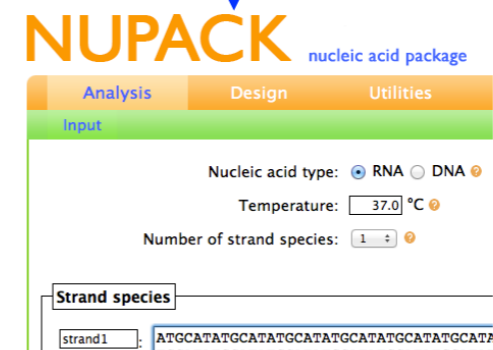

Sequence design informed by thermodynamic parameters of DNA base interactions. Other sequence design tools will also be used depending on the goal.

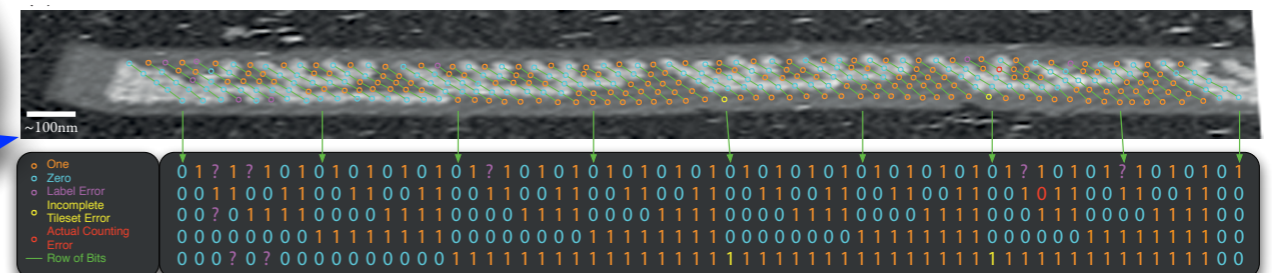

Constantine Evans. PhD Thesis. Caltech. 2014. Winfree group

Algorithmic DNA tile assembly pipeline

- 1. High-level logical design using abstract Tile Assembly Model
- 2. Choose strength of sticky end strengths using kinetic Tile Assembly Model
 - Desired: strong enough sticky ends so that correct tiles stick, but weak enough so that wrong tiles quickly fall off
- 3. DNA sequence design
 - Choose DNA sequences for the sticky ends (getting the right strength)
 - Choose DNA sequences for the tile core (easier---no dynamics here)
- 4. Synthesize & purify DNA strands (easy, pay a synthesis company a few quid per strand)
- 5. Mix with water & ionic buffer, heat to 90C, cool slowly enough (and/or temperature hold)
- 6. Image:
 - Atomic force microscopy (fine scale)
 - Fluorescence microscopy (large scale)

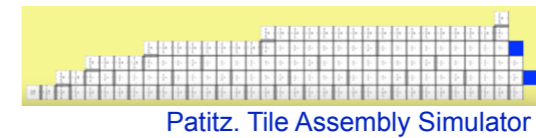

Logical design and simulation

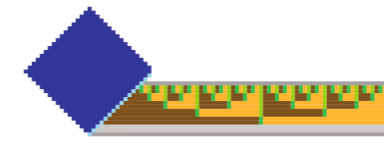
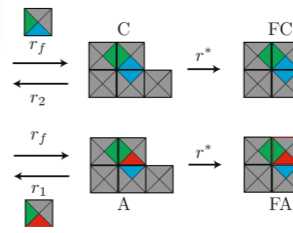

Simulation of kinetics of tile binding and unbinding (a crystal growth process)

Evans, Winfree. DNA19. 2012

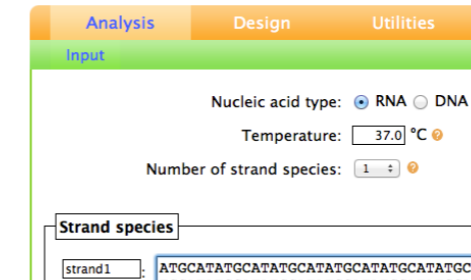

Sequence design informed by thermodynamic parameters of DNA base interactions. Other sequence design tools will also be used depending on the goal.

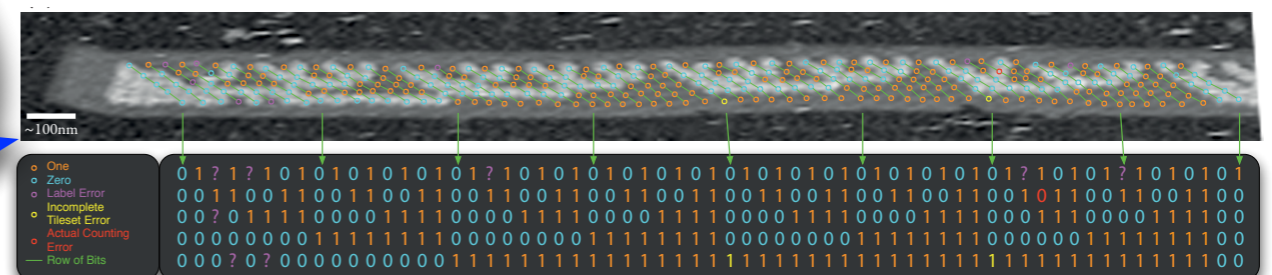

Computation and geometry

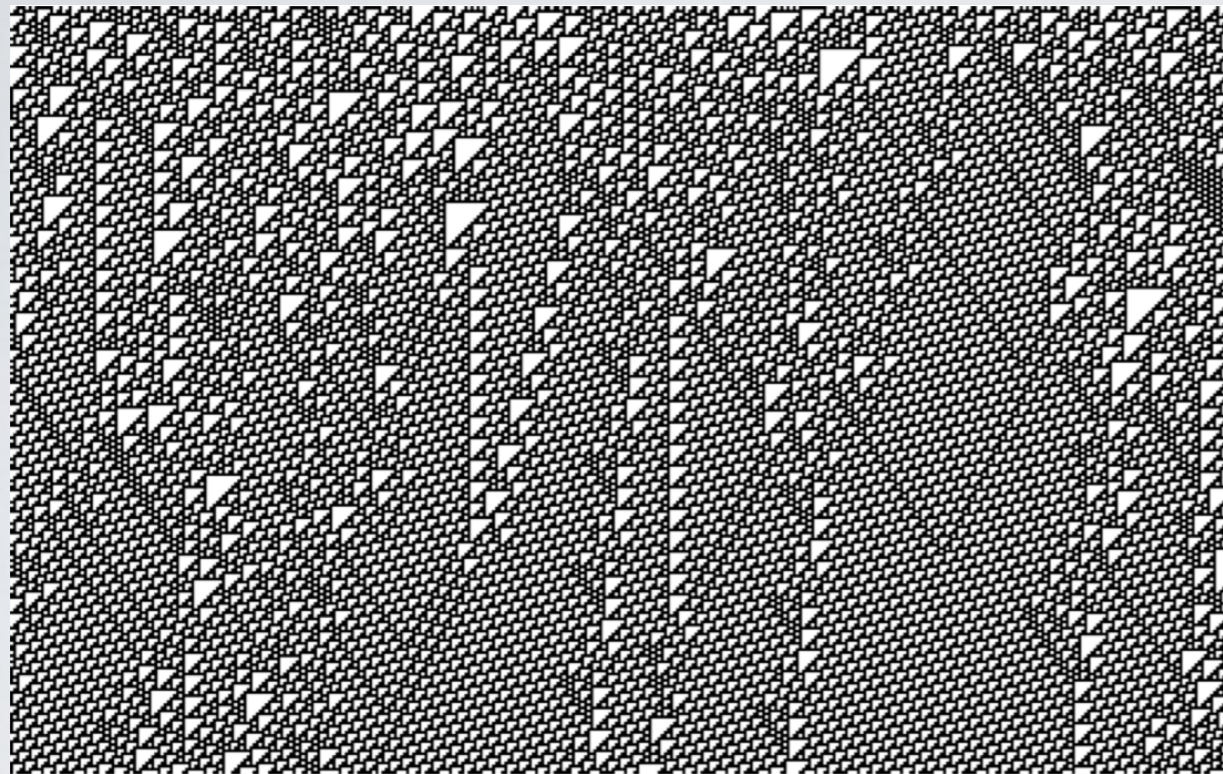

Rule 110 - from Cook. Complex Sys 2004.

Time

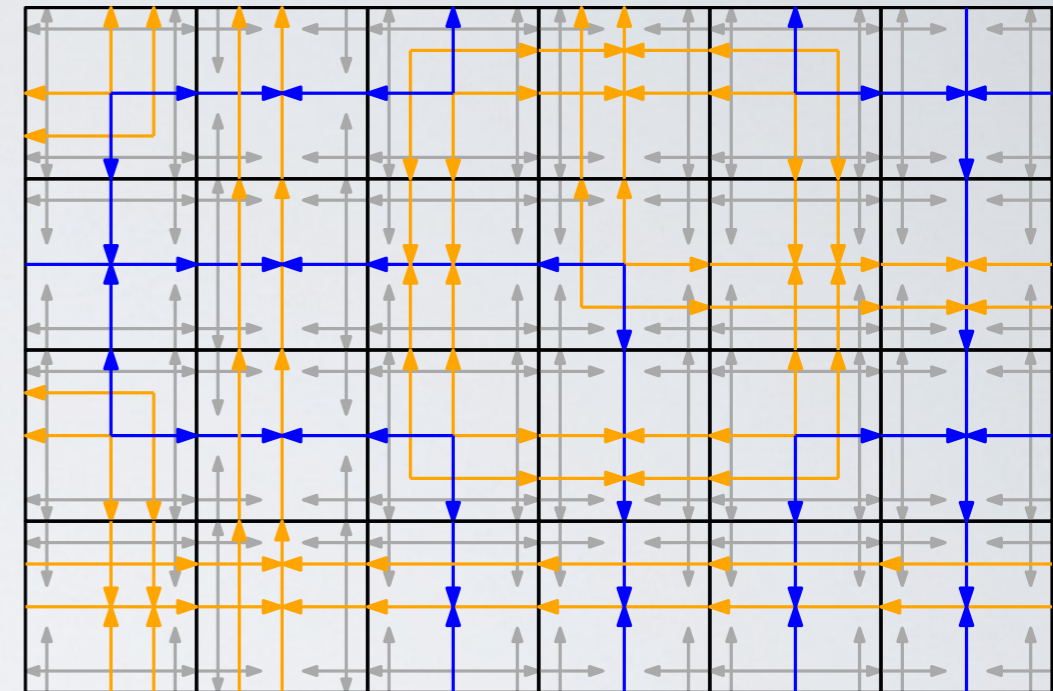

Rotatable Wang tiles
Portion of a tiling of Robinson's
10-tile aperiodic square tile set

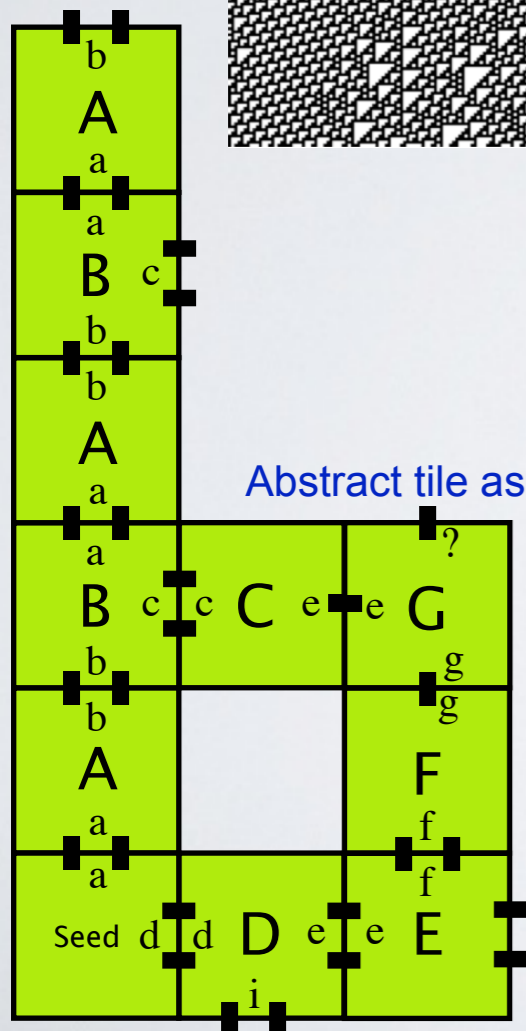

Abstract tile assembly model.
Winfree 1998

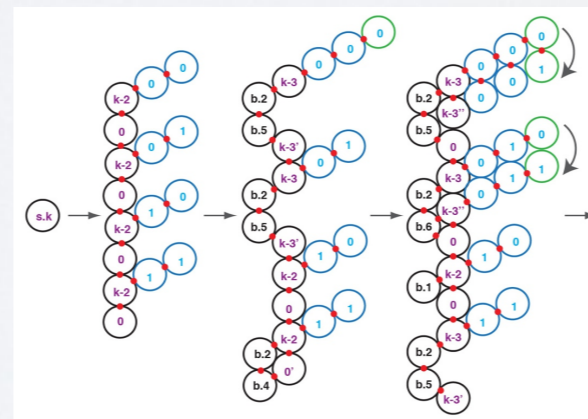

Nubots - From Woods, Chen, Goodfriend, Dabby, Winfree, Yin. ITCS 2013

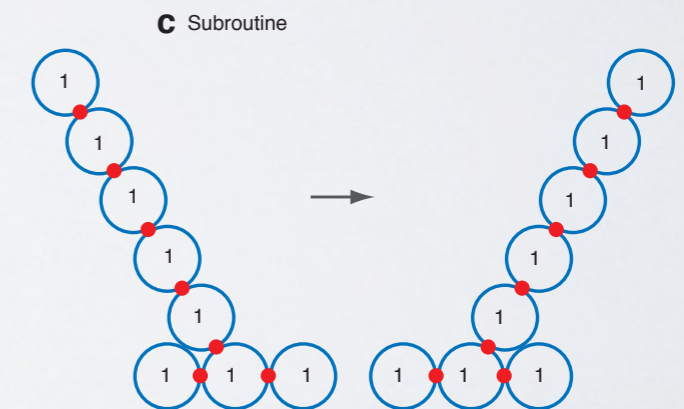

A zoo of tile assembly models

abstract tile
assembly model

temperature 1

temperature 2

...

Two-handed/hierarchical
tile assembly model

dupled abstract tile
assembly model

kinetic tile
assembly model

polyomino tile
assembly model

signal-passing tile
assembly model

polygonal free-body tile
assembly model

RNase tile
assembly model

negative glue tile
assembly model

geometric tile
assembly model

Flexible glue tile
assembly model

dupled restricted glue
tile assembly model

How to compare
these models?

Our journey

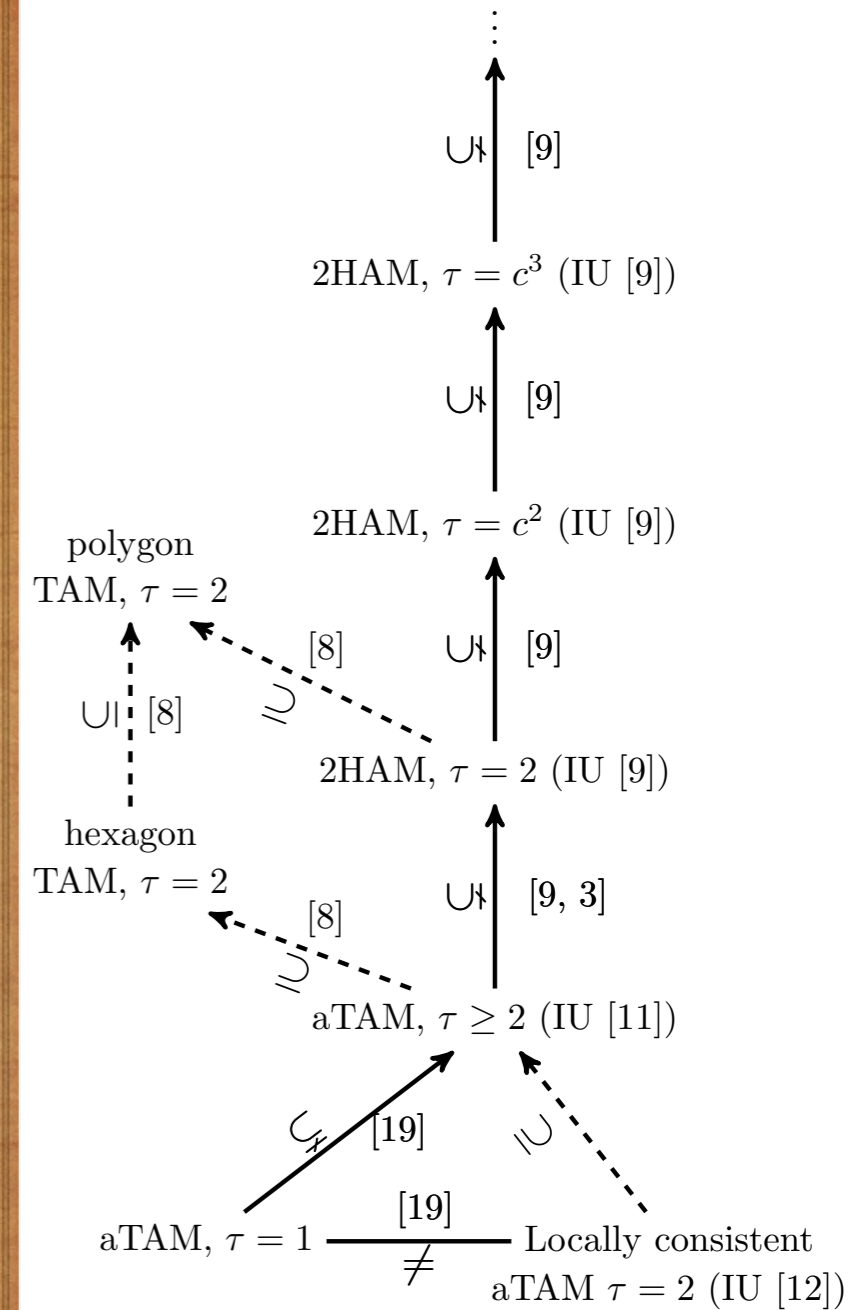

Our journey



$\alpha_{TAM}, \tau \geq 2$ (IU [11])

Abstract tile assembly model

- Square **tiles**
 - finite set of tile types, unlimited supply of each type, non-rotatable
- Each side has a **glue** (a,b,c,d,...)
- Each glue has a **strength** (0,1,2,3,...)
- System has a **temperature** (e.g. 2)

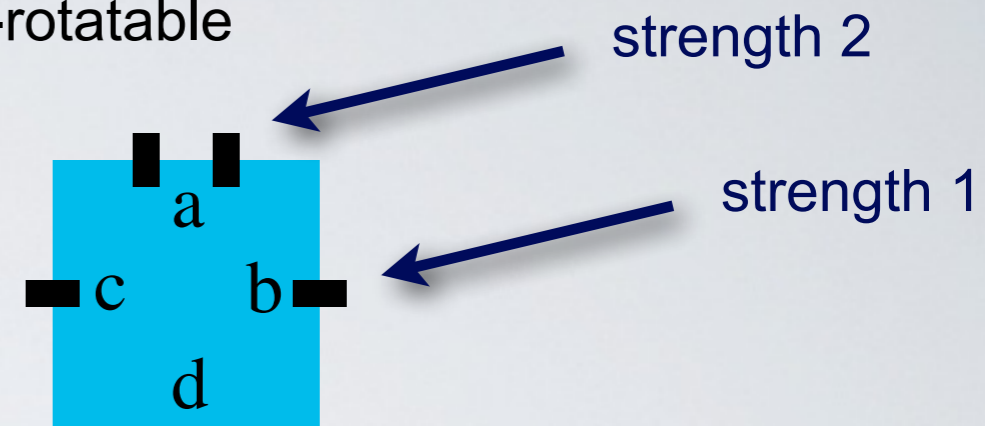

Introduced by
Winfree, 1998

Abstract tile assembly model

- Square **tiles**
 - finite set of tile types, unlimited supply of each type, non-rotatable
- Each side has a **glue** (a,b,c,d,...)
- Each glue has a **strength** (0,1,2,3,...)
- System has a **temperature** (e.g. 2)

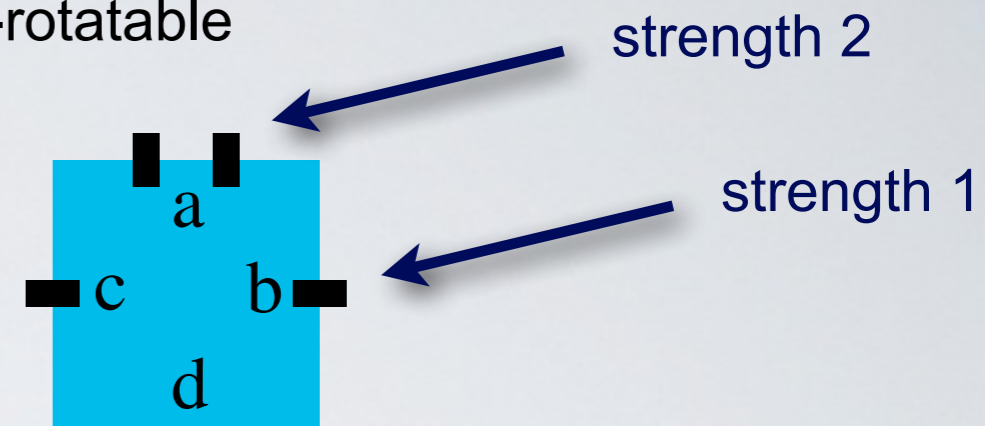

- Growth begins from a special **seed** tile
- Asynchronous local update
- A tile **sticks** to an assembly if the sum of the strengths of the matching glues is at least the **temperature**

Introduced by
Winfree, 1998

Abstract tile assembly model

- Square **tiles**
 - finite set of tile types, unlimited supply of each type, non-rotatable
- Each side has a **glue** (a,b,c,d,...)
- Each glue has a **strength** (0,1,2,3,...)
- System has a **temperature** (e.g. 2)

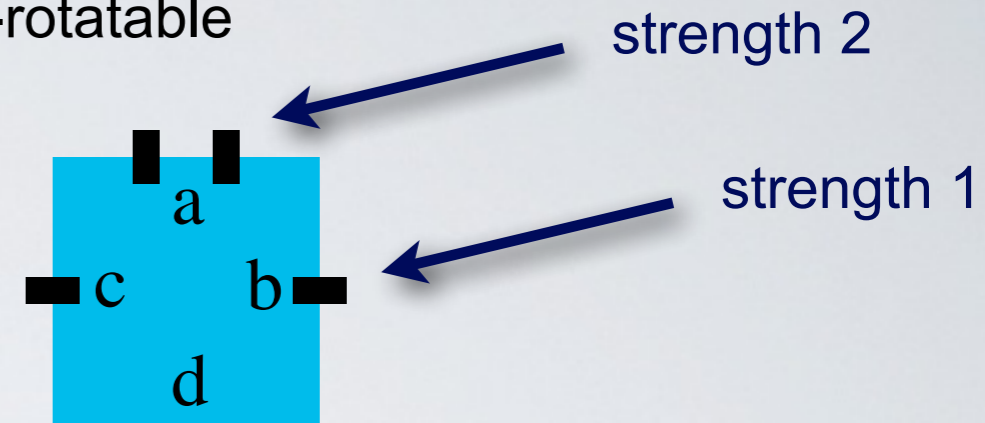

- Growth begins from a special **seed** tile
- Asynchronous local update
- A tile **sticks** to an assembly if the sum of the strengths of the matching glues is at least the **temperature**

Introduced by
Winfree, 1998

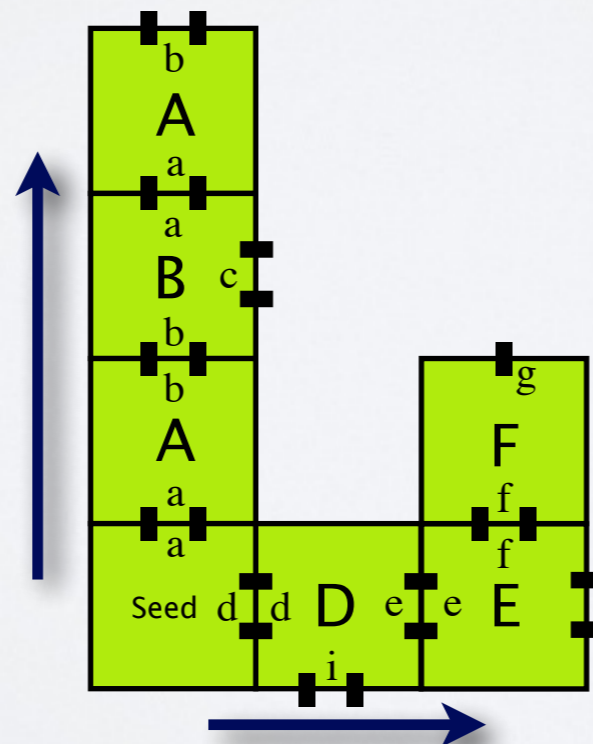

Abstract tile assembly model

- Square **tiles**
 - finite set of tile types, unlimited supply of each type, non-rotatable
- Each side has a **glue** (a,b,c,d,...)
- Each glue has a **strength** (0,1,2,3,...)
- System has a **temperature** (e.g. 2)

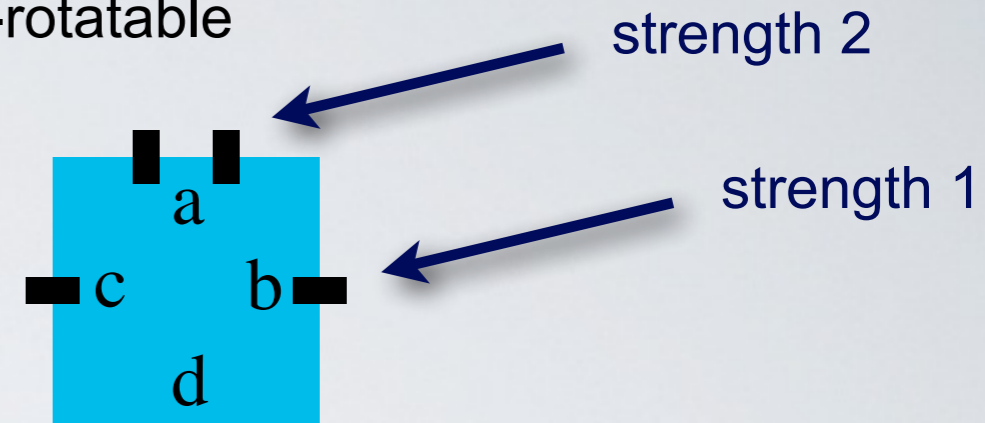

- Growth begins from a special **seed** tile
- Asynchronous local update
- A tile **sticks** to an assembly if the sum of the strengths of the matching glues is at least the **temperature**

Introduced by
Winfree, 1998

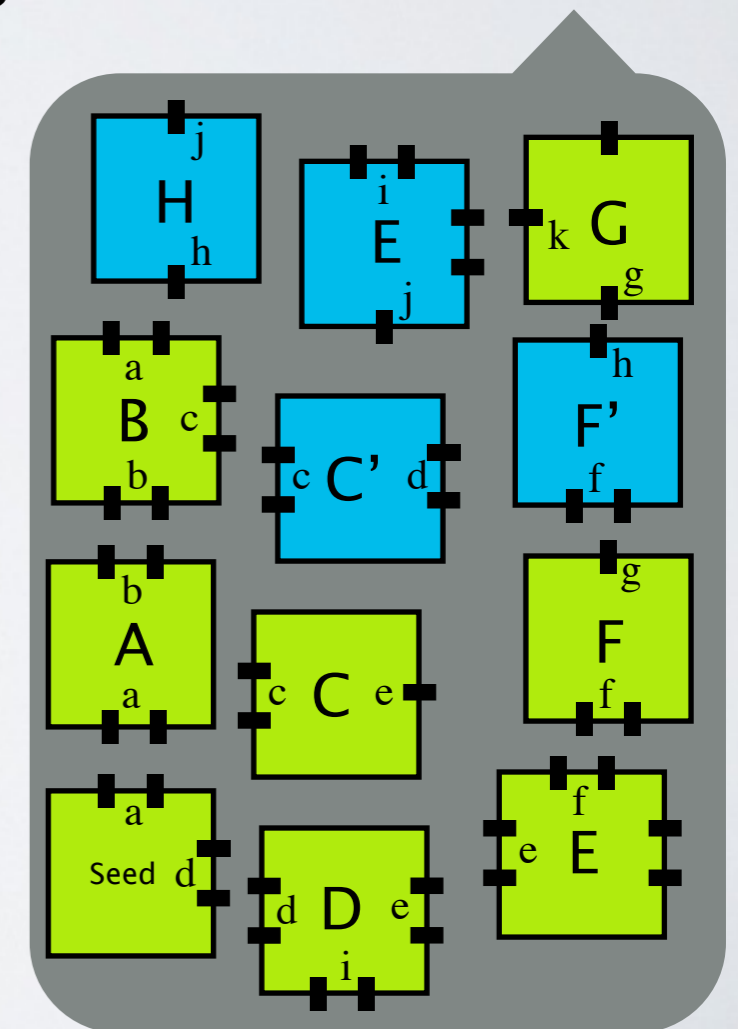
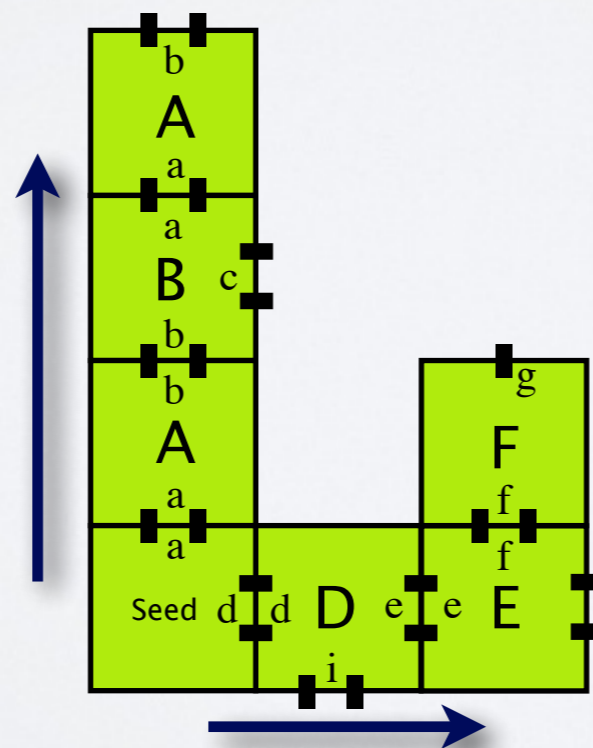

Temperature = 2

Abstract tile assembly model

- Square **tiles**
 - finite set of tile types, unlimited supply of each type, non-rotatable
- Each side has a **glue** (a,b,c,d,...)
- Each glue has a **strength** (0,1,2,3,...)
- System has a **temperature** (e.g. 2)

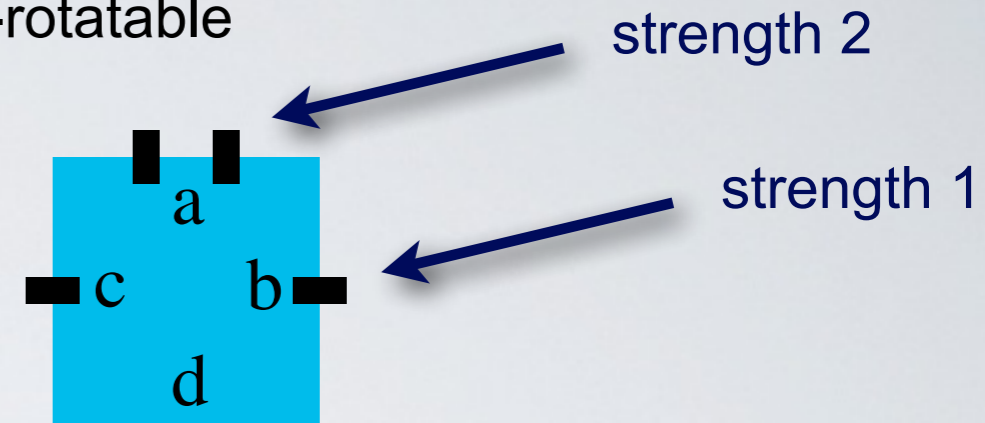

- Growth begins from a special **seed** tile
- Asynchronous local update
- A tile **sticks** to an assembly if the sum of the strengths of the matching glues is at least the **temperature**

- **Tile assembly system**
= **tile set, seed tile, temperature** (0,1,2,3,...)

Introduced by
Winfree, 1998

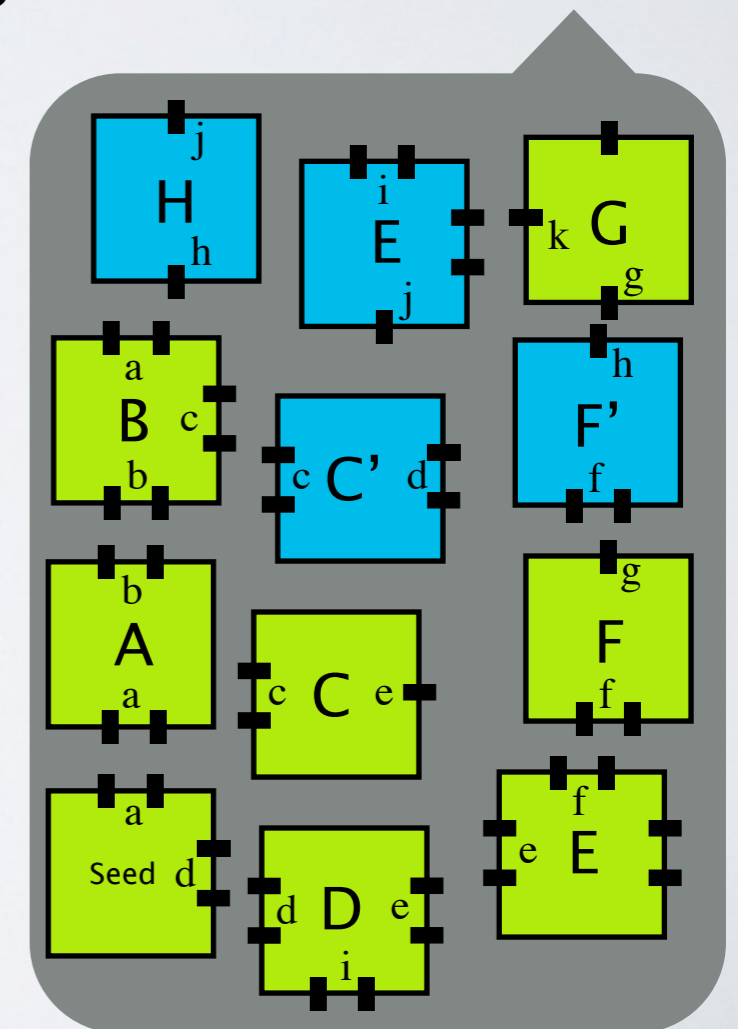
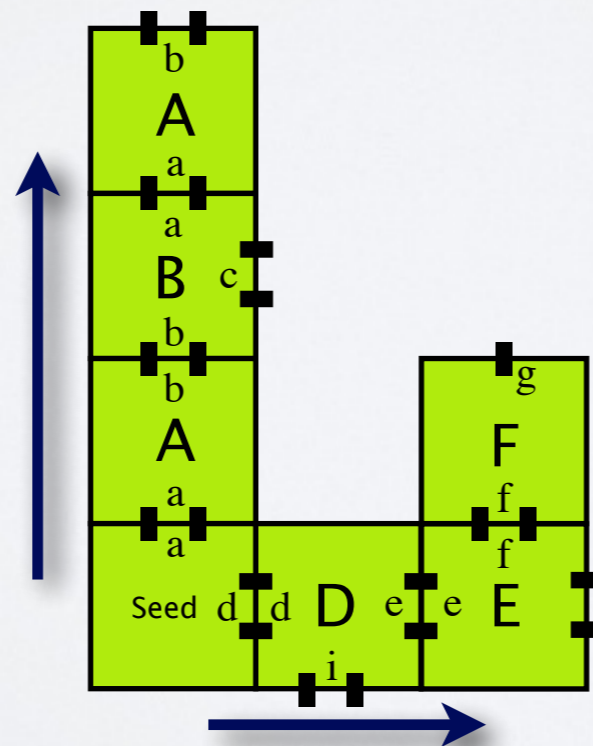

Temperature = 2

Abstract tile assembly model

Tile assembly system:
tile set, seed tile, temperature

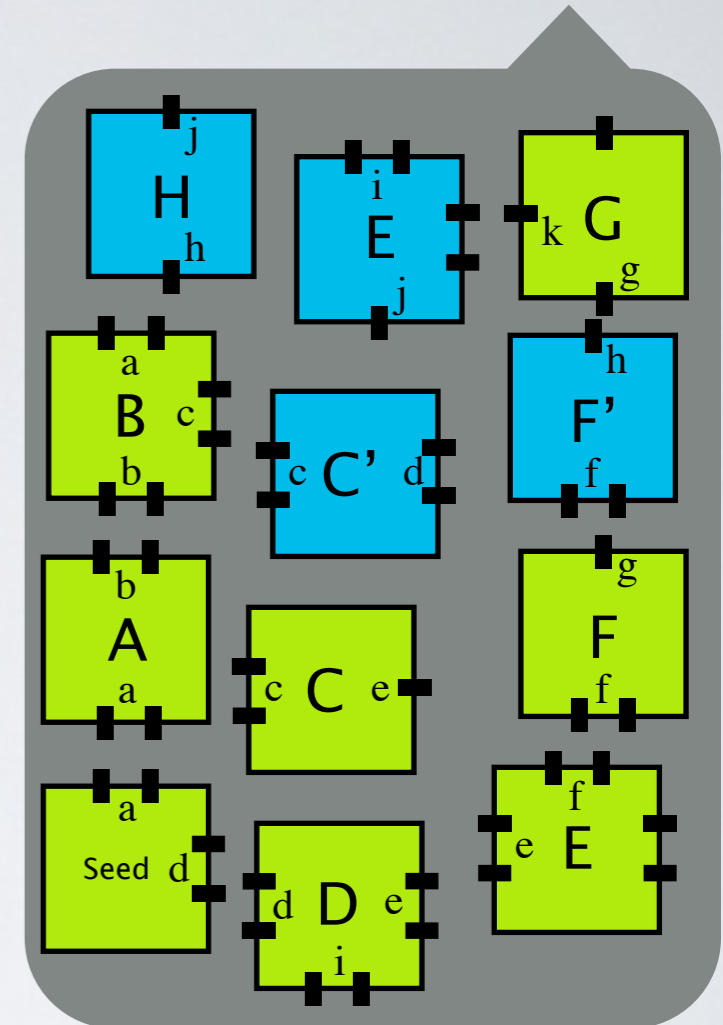
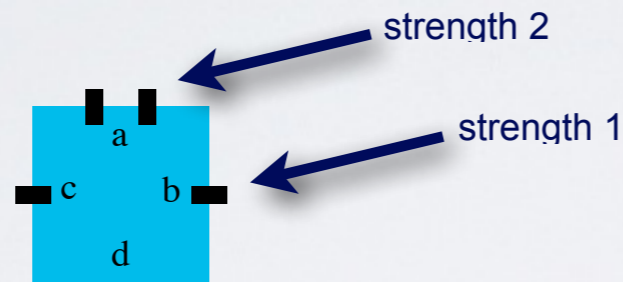
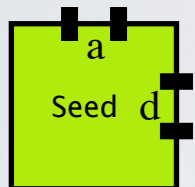

Temperature = 2

- Finite set of square **tiles**, each side has a **glue** and **strength**
- **Tile assembly system:** [tile set, seed tile, temperature (0,1,2,3,...)]
- Growth begins from the **seed** tile/assembly
- A tile **sticks** to an assembly if enough of its glues match so that the sum of the strengths of the matching glues is at least the **temperature**

Abstract tile assembly model

Tile assembly system:
tile set, seed tile, temperature

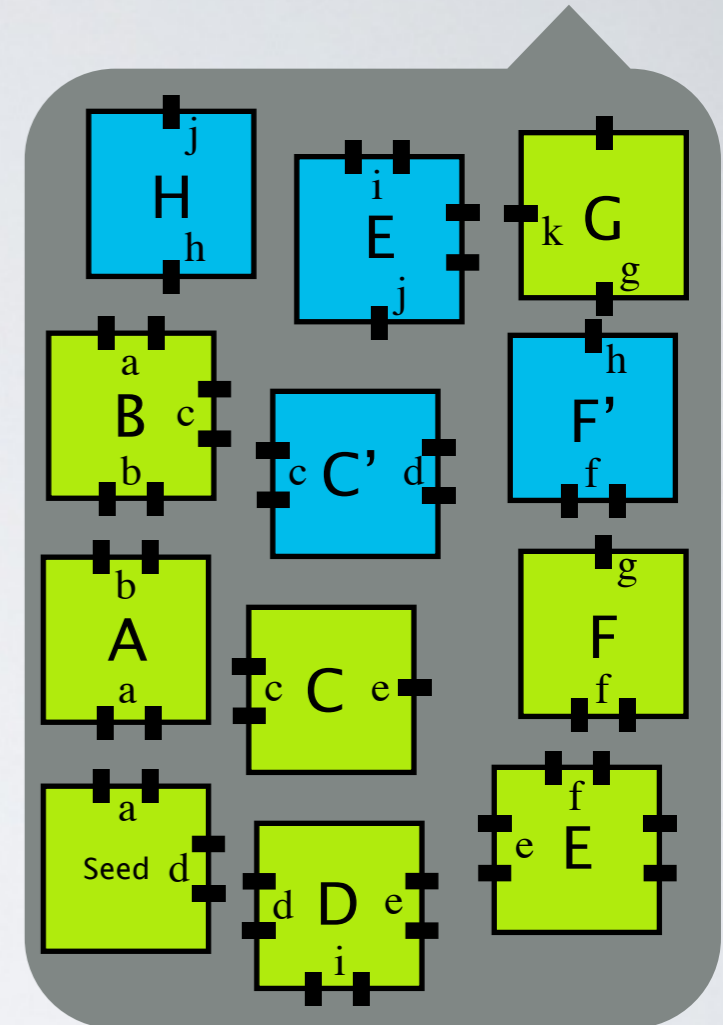
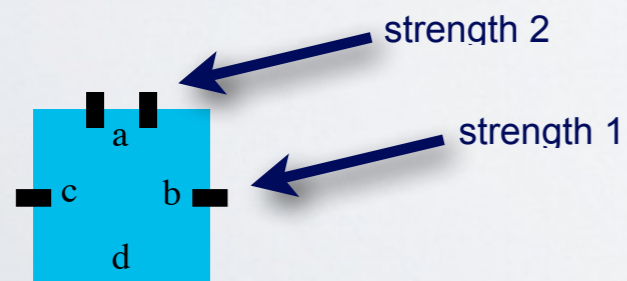
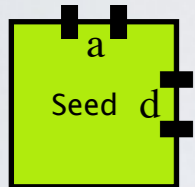

Temperature = 2

- Finite set of square **tiles**, each side has a **glue** and **strength**
- **Tile assembly system:** [tile set, seed tile, temperature (0,1,2,3,...)]
- Growth begins from the **seed** tile/assembly
- A tile **sticks** to an assembly if enough of its glues match so that the sum of the strengths of the matching glues is at least the **temperature**

Abstract tile assembly model

Tile assembly system:
tile set, seed tile, temperature

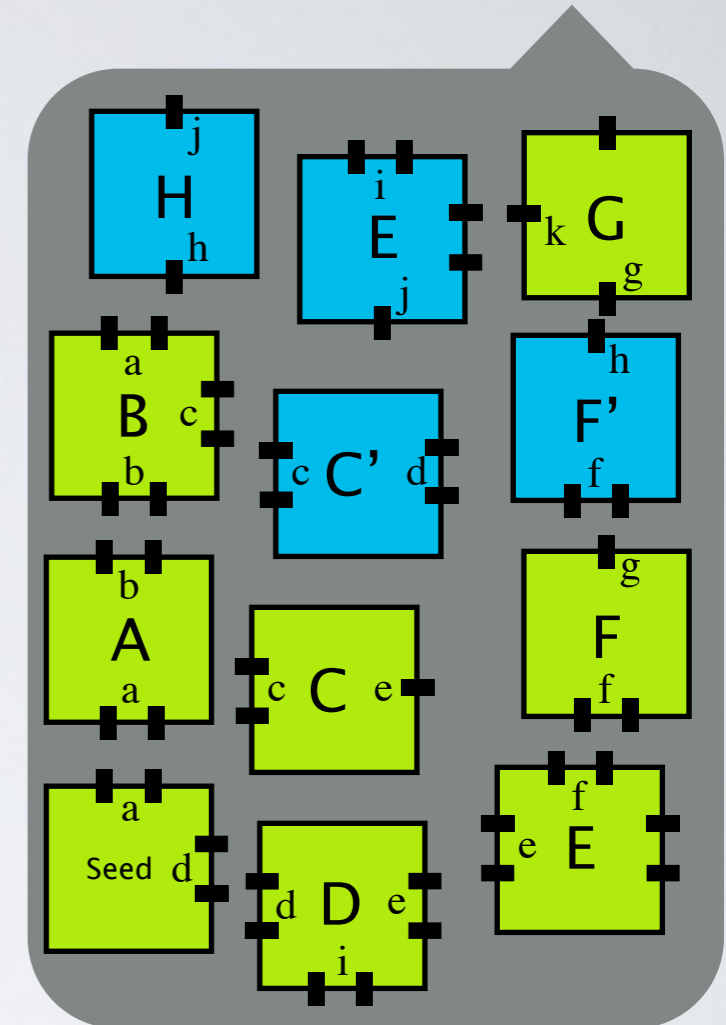
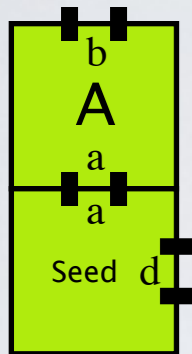

Temperature = 2

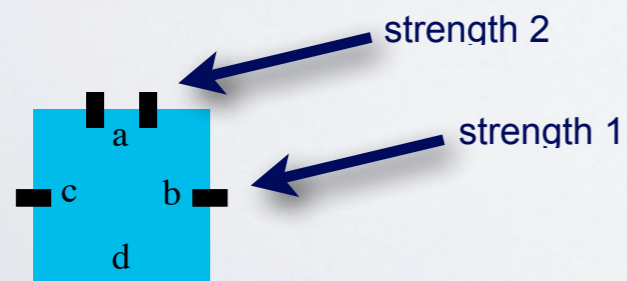

- Finite set of square **tiles**, each side has a **glue** and **strength**
- **Tile assembly system:** [tile set, seed tile, temperature (0,1,2,3,...)]
- Growth begins from the **seed** tile/assembly
- A tile **sticks** to an assembly if enough of its glues match so that the sum of the strengths of the matching glues is at least the **temperature**

Abstract tile assembly model

Tile assembly system:
tile set, seed tile, temperature

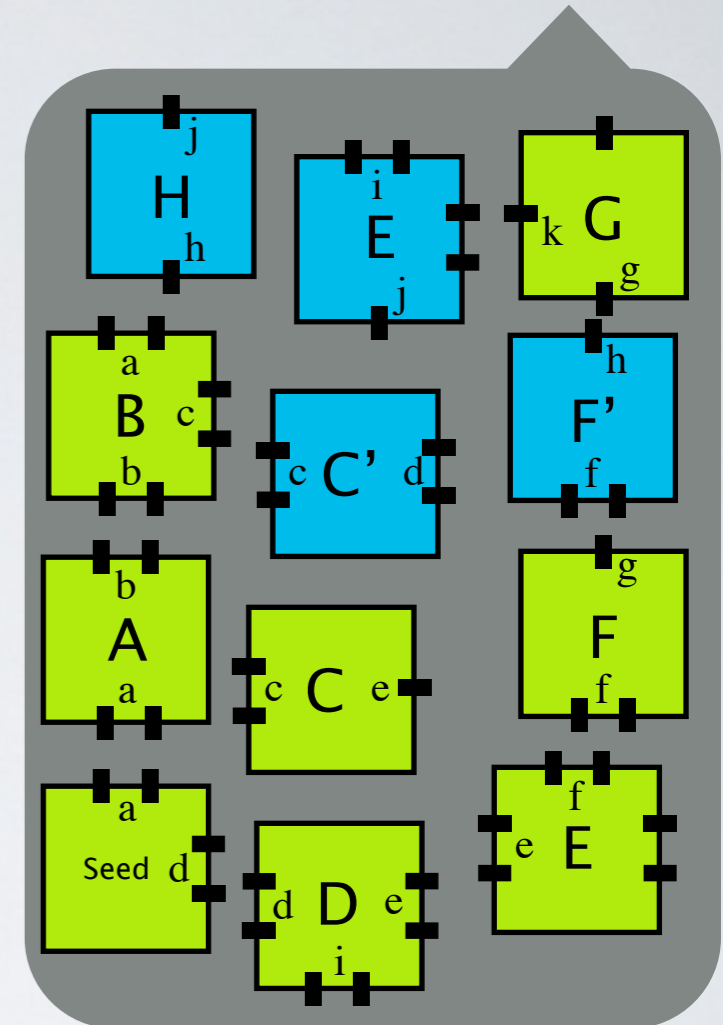
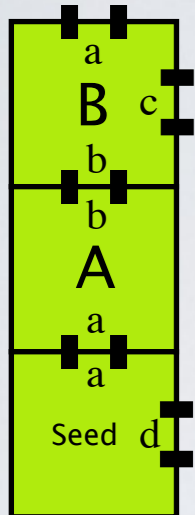

Temperature = 2

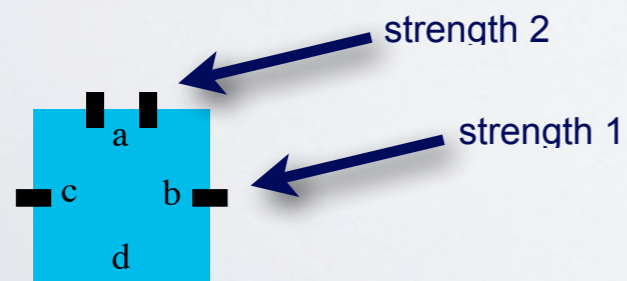

- Finite set of square **tiles**, each side has a **glue** and **strength**
- **Tile assembly system:** [tile set, seed tile, temperature (0,1,2,3,...)]
- Growth begins from the **seed** tile/assembly
- A tile **sticks** to an assembly if enough of its glues match so that the sum of the strengths of the matching glues is at least the **temperature**

Abstract tile assembly model

Tile assembly system:
tile set, seed tile, temperature

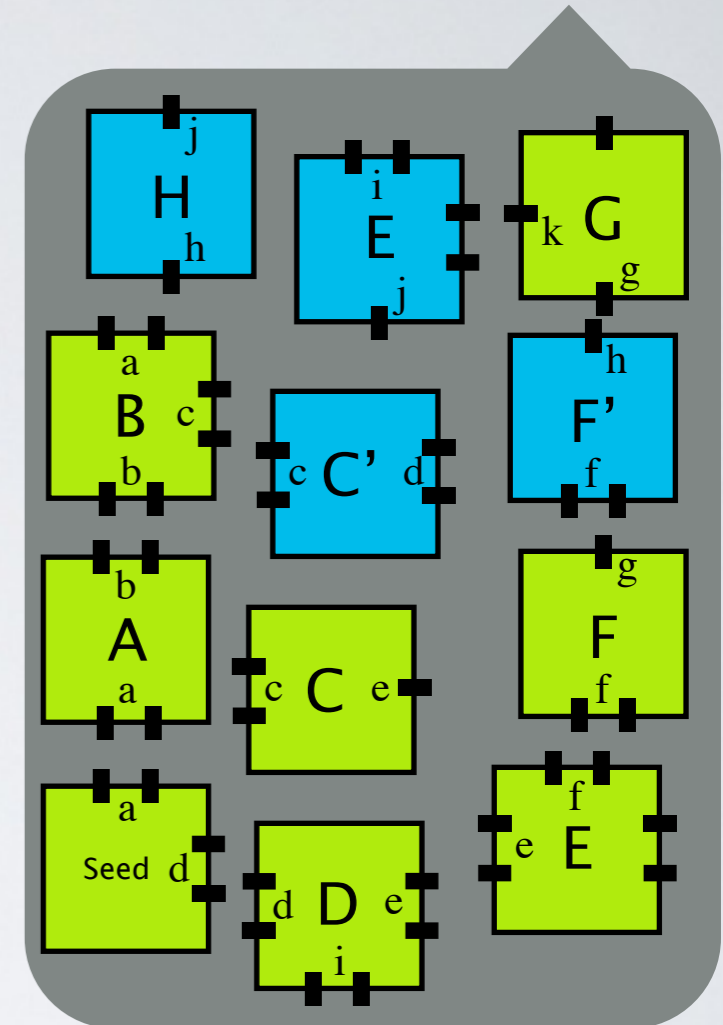
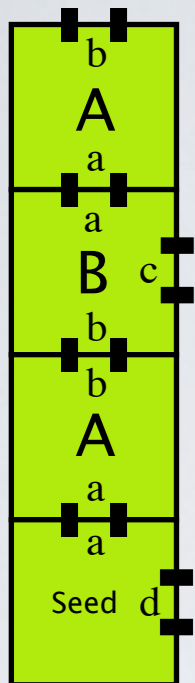

Temperature = 2

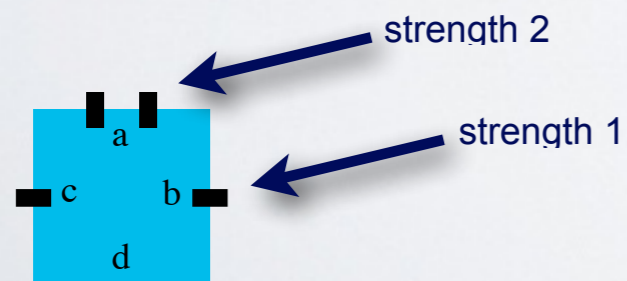

- Finite set of square **tiles**, each side has a **glue** and **strength**
- **Tile assembly system:** [tile set, seed tile, temperature (0,1,2,3,...)]
- Growth begins from the **seed** tile/assembly
- A tile **sticks** to an assembly if enough of its glues match so that the sum of the strengths of the matching glues is at least the **temperature**

Abstract tile assembly model

Tile assembly system:
tile set, seed tile, temperature

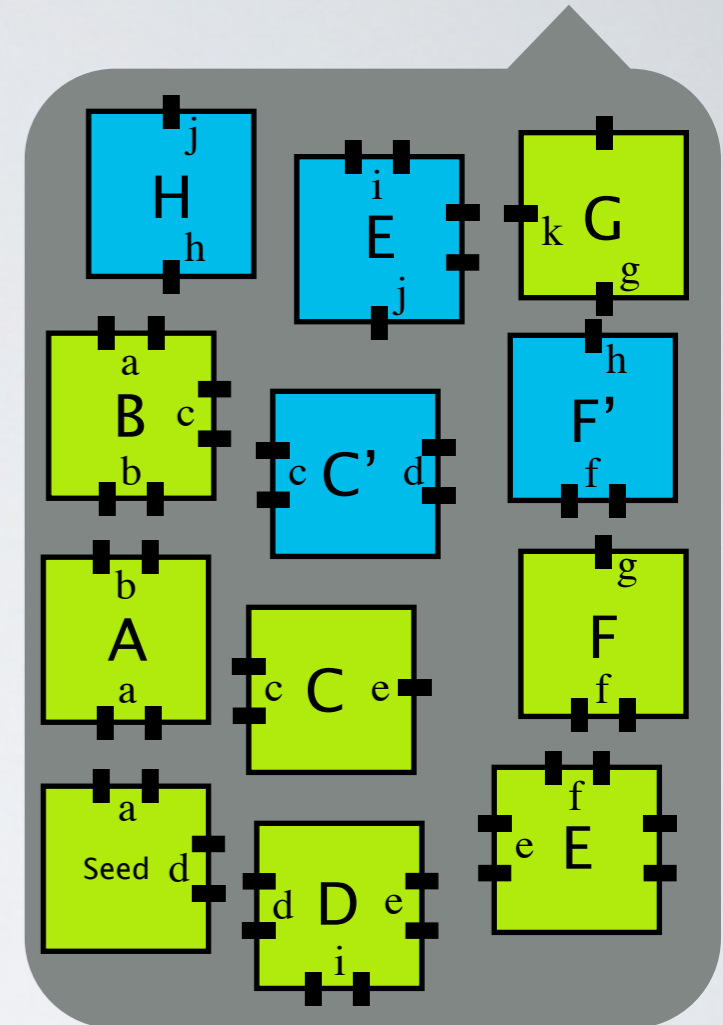
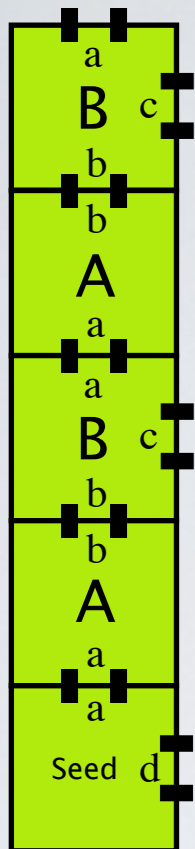

Temperature = 2

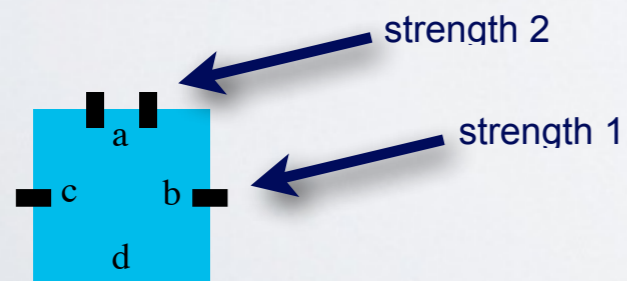

- Finite set of square **tiles**, each side has a **glue** and **strength**
- **Tile assembly system:** [tile set, seed tile, temperature (0,1,2,3,...)]
- Growth begins from the **seed** tile/assembly
- A tile **sticks** to an assembly if enough of its glues match so that the sum of the strengths of the matching glues is at least the **temperature**

Abstract tile assembly model

Tile assembly system:
tile set, seed tile, temperature

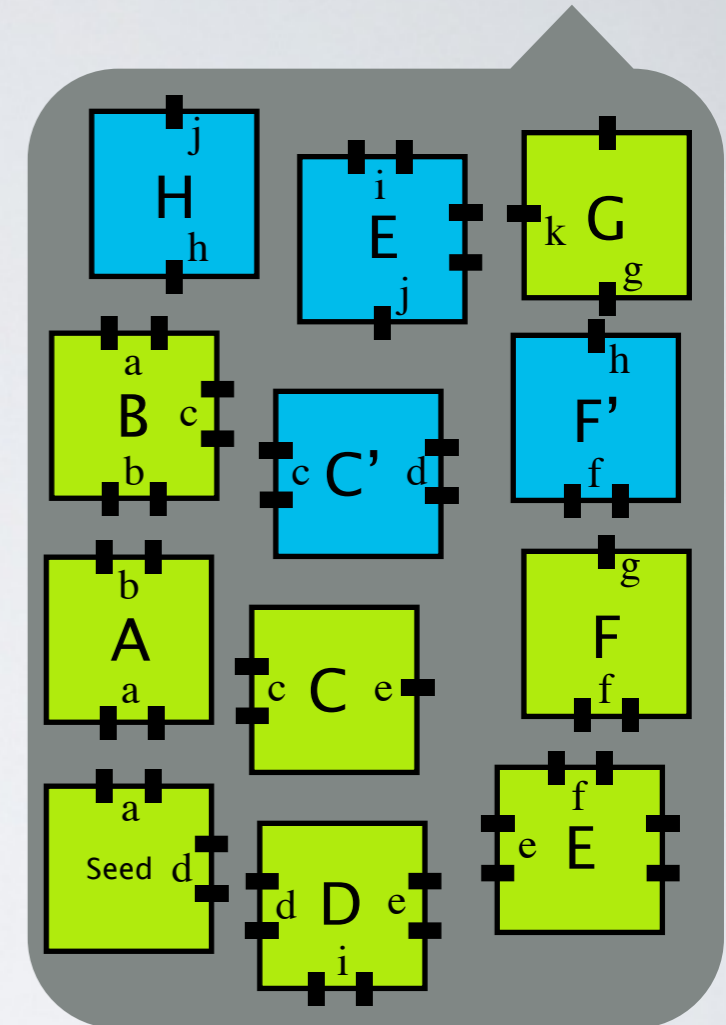
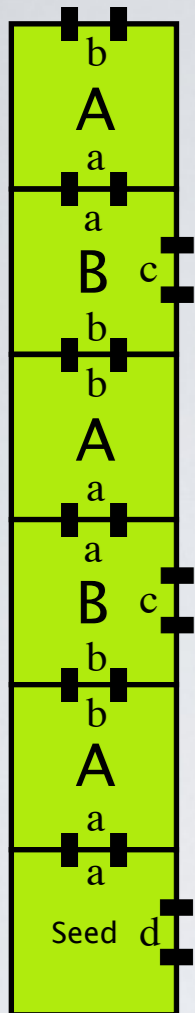

Temperature = 2

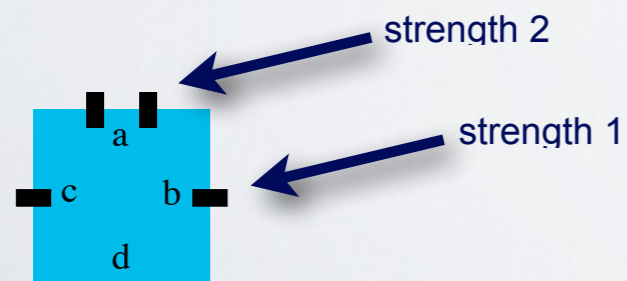

- Finite set of square **tiles**, each side has a **glue** and **strength**
- **Tile assembly system:** [tile set, seed tile, temperature (0,1,2,3,...)]
- Growth begins from the **seed** tile/assembly
- A tile **sticks** to an assembly if enough of its glues match so that the sum of the strengths of the matching glues is at least the **temperature**

Abstract tile assembly model

Tile assembly system:
tile set, seed tile, temperature

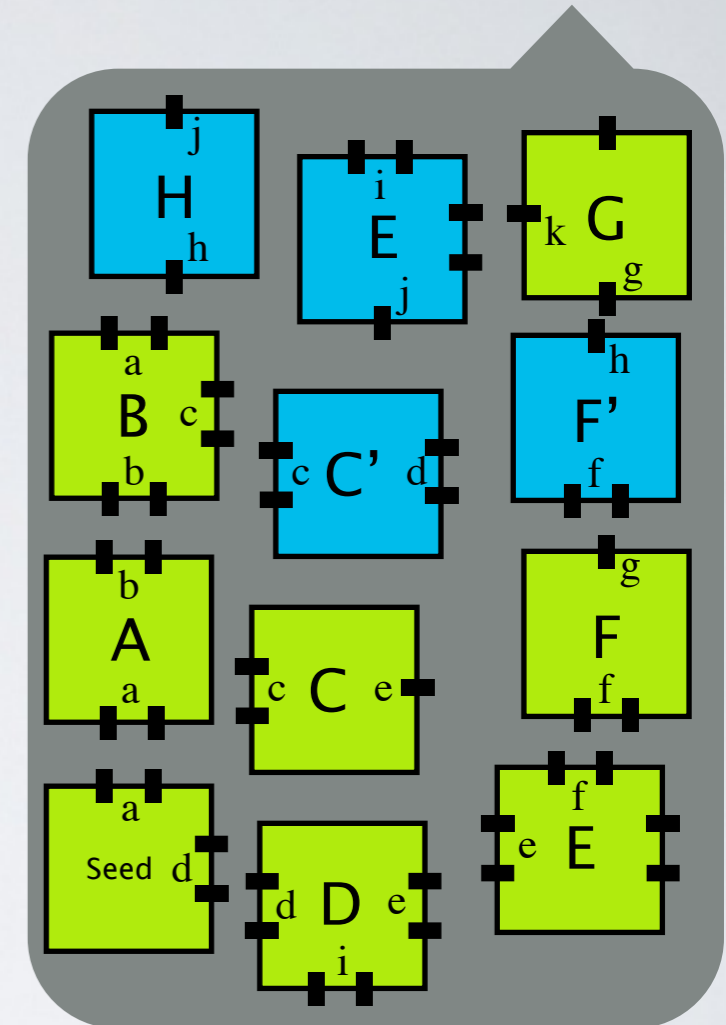
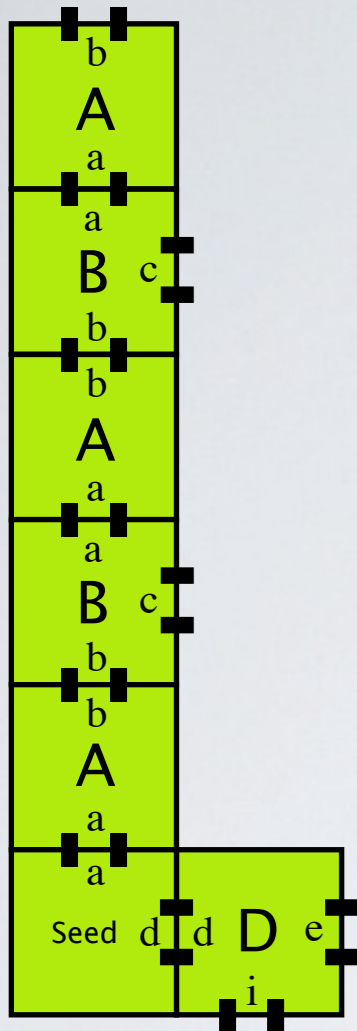

Temperature = 2

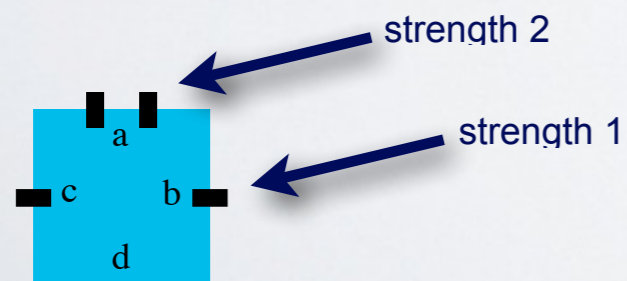

- Finite set of square **tiles**, each side has a **glue** and **strength**
- **Tile assembly system:** [tile set, seed tile, temperature (0,1,2,3,...)]
- Growth begins from the **seed** tile/assembly
- A tile **sticks** to an assembly if enough of its glues match so that the sum of the strengths of the matching glues is at least the **temperature**

Abstract tile assembly model

Tile assembly system:
tile set, seed tile, temperature

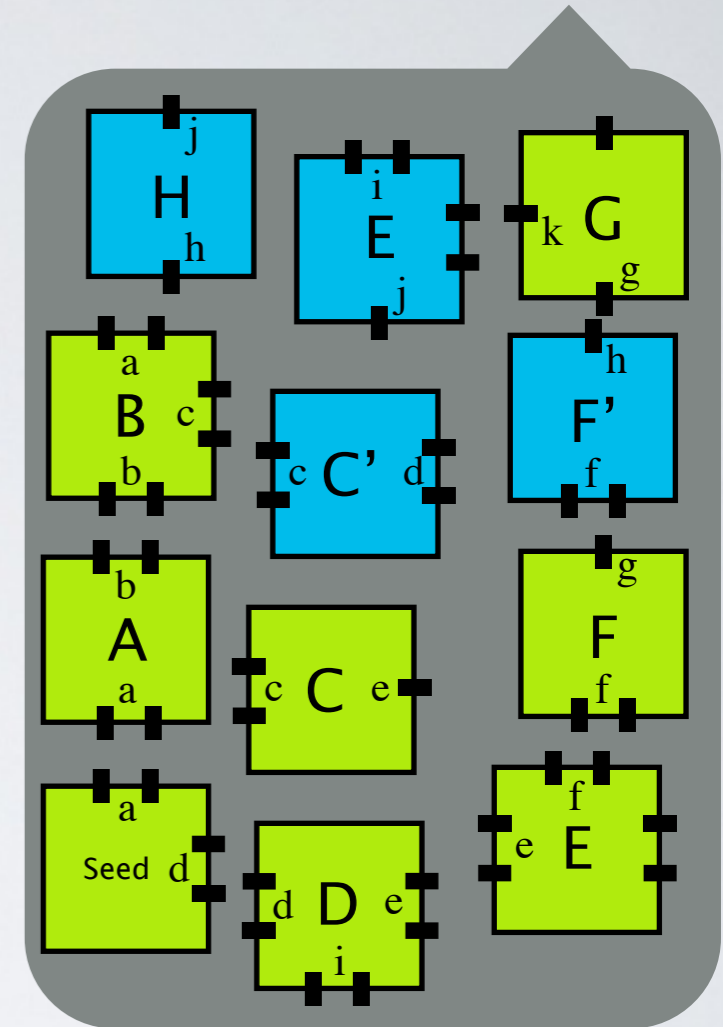
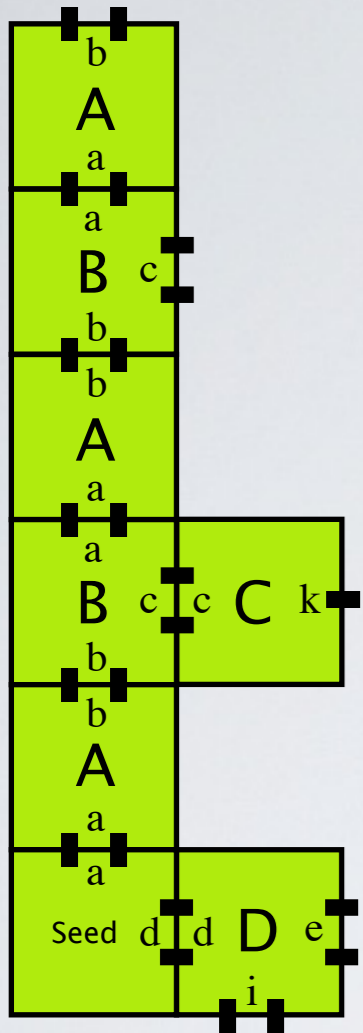

Temperature = 2

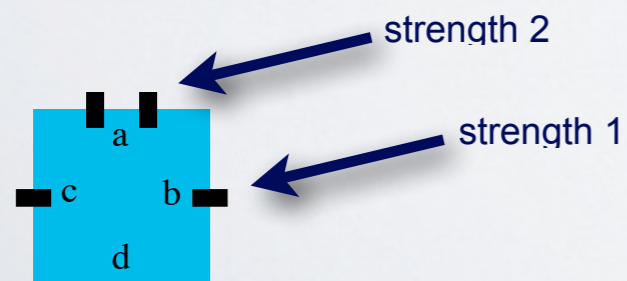

- Finite set of square **tiles**, each side has a **glue** and **strength**
- **Tile assembly system:** [tile set, seed tile, temperature (0,1,2,3,...)]
- Growth begins from the **seed** tile/assembly
- A tile **sticks** to an assembly if enough of its glues match so that the sum of the strengths of the matching glues is at least the **temperature**

Abstract tile assembly model

Tile assembly system:
tile set, seed tile, temperature

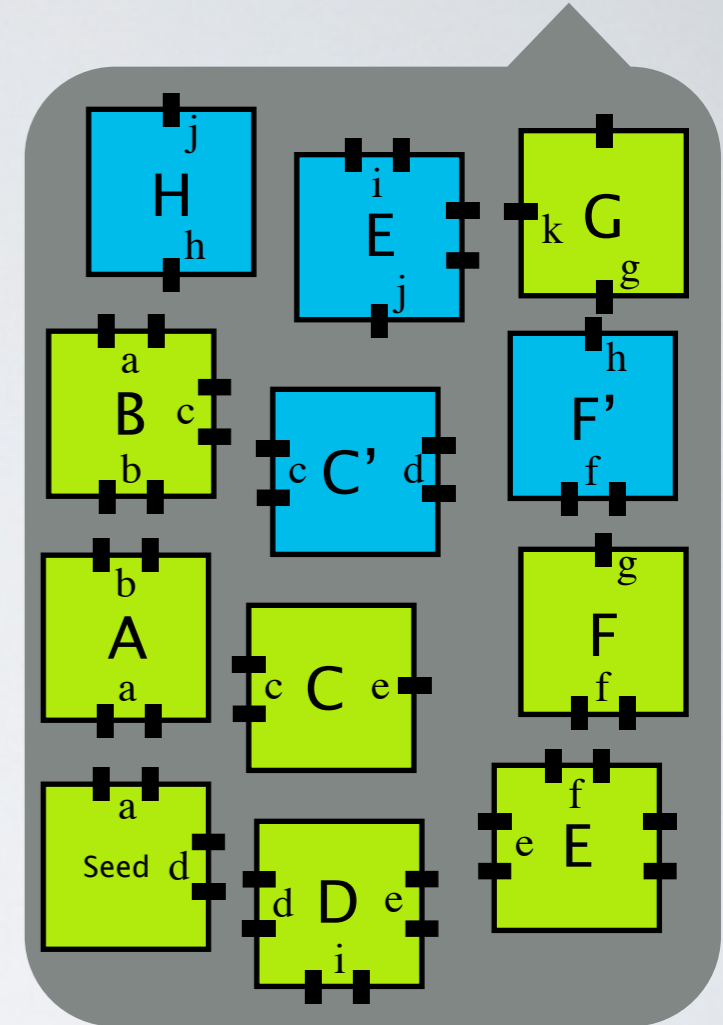
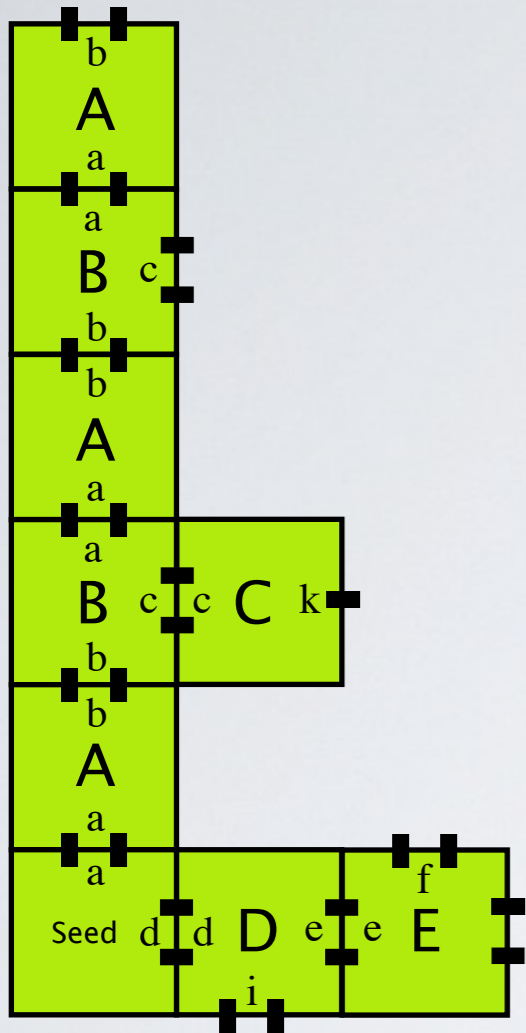

Temperature = 2

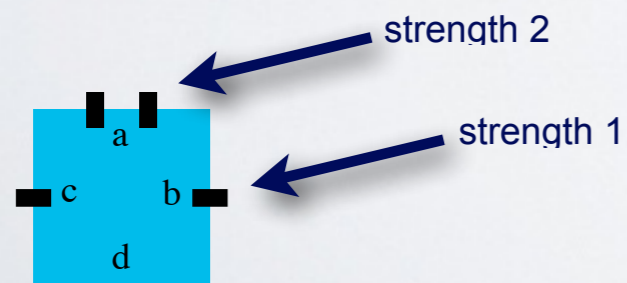

- Finite set of square **tiles**, each side has a **glue** and **strength**
- **Tile assembly system:** [tile set, seed tile, temperature (0,1,2,3,...)]
- Growth begins from the **seed** tile/assembly
- A tile **sticks** to an assembly if enough of its glues match so that the sum of the strengths of the matching glues is at least the **temperature**

Abstract tile assembly model

Tile assembly system:
tile set, seed tile, temperature

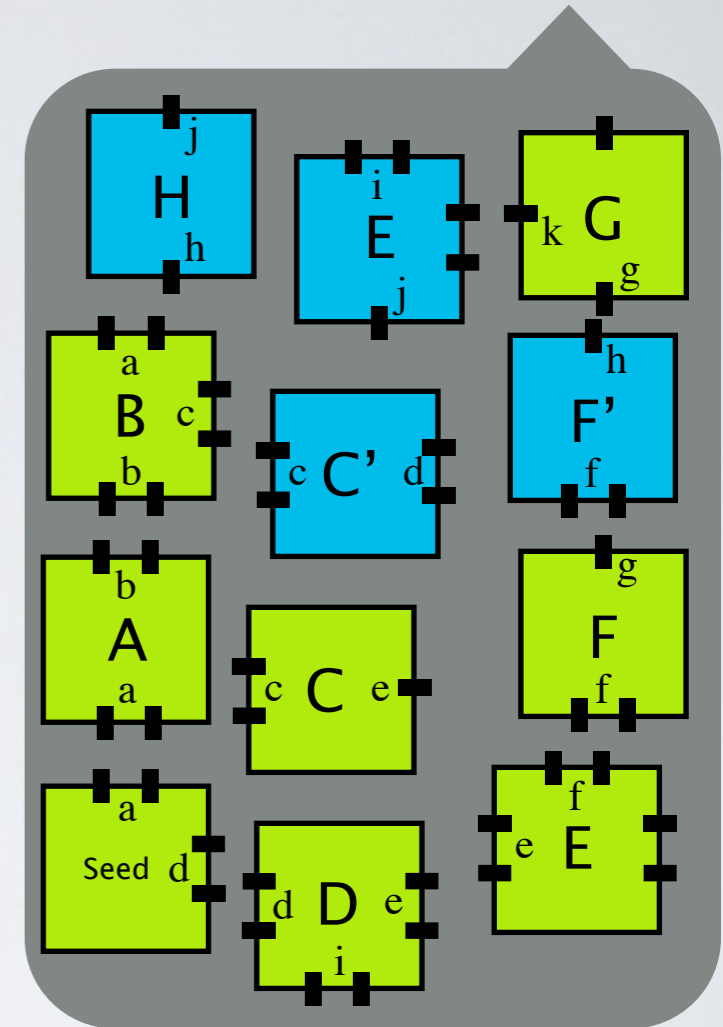
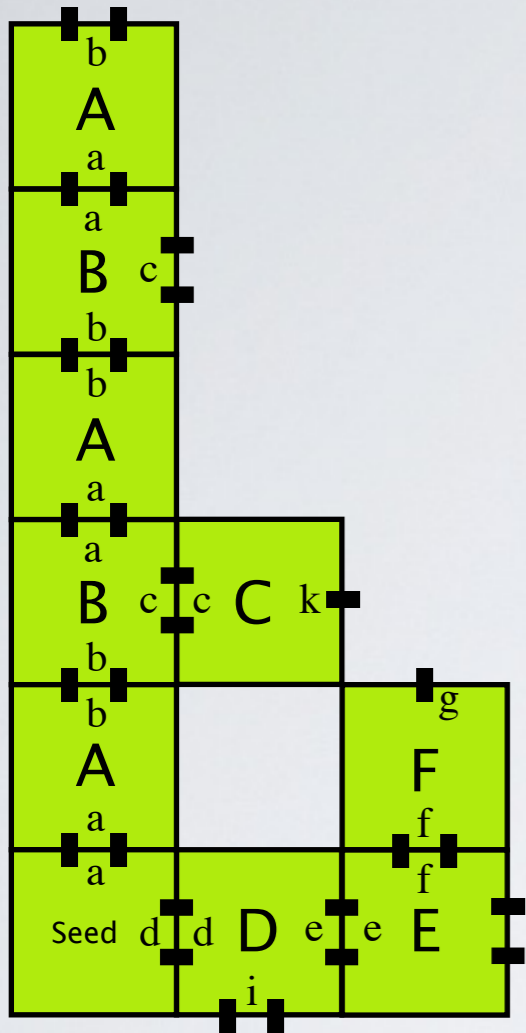

Temperature = 2

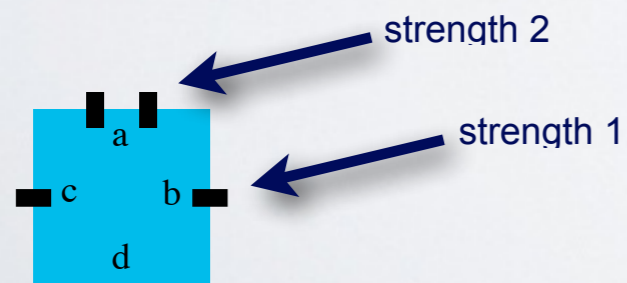

- Finite set of square **tiles**, each side has a **glue** and **strength**
- **Tile assembly system:** [tile set, seed tile, temperature (0,1,2,3,...)]
- Growth begins from the **seed** tile/assembly
- A tile **sticks** to an assembly if enough of its glues match so that the sum of the strengths of the matching glues is at least the **temperature**

Abstract tile assembly model

Tile assembly system:
tile set, seed tile, temperature

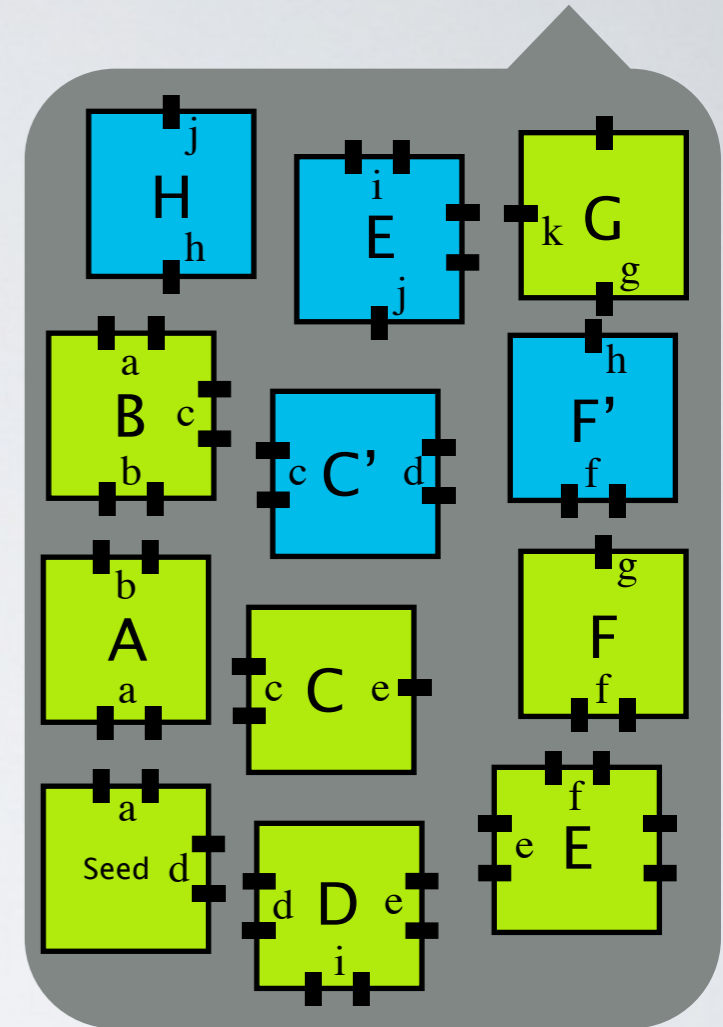
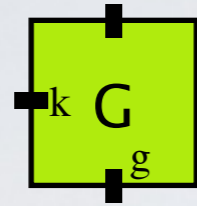
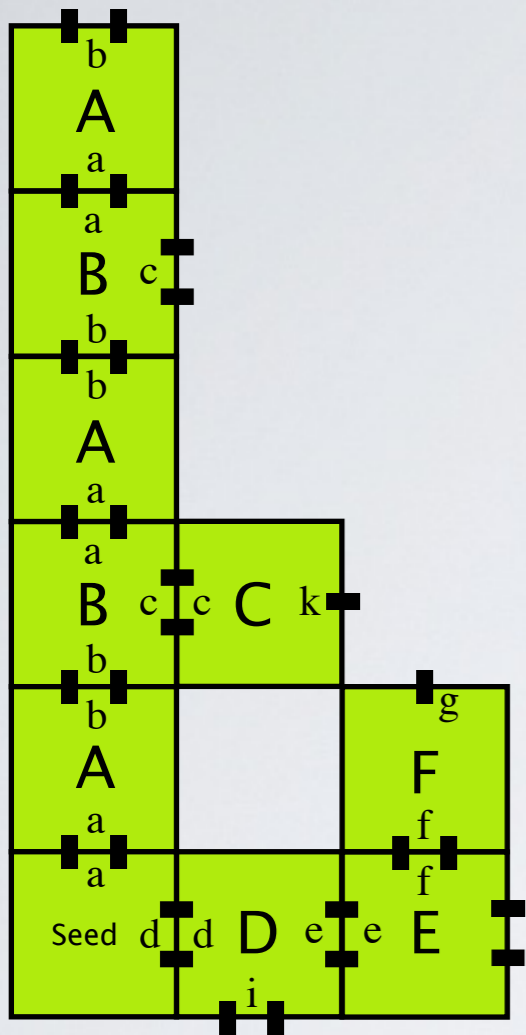

Temperature = 2

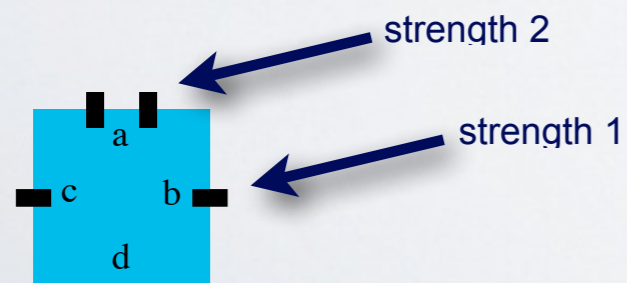

- Finite set of square **tiles**, each side has a **glue** and **strength**
- **Tile assembly system:** [tile set, seed tile, temperature (0,1,2,3,...)]
- Growth begins from the **seed** tile/assembly
- A tile **sticks** to an assembly if enough of its glues match so that the sum of the strengths of the matching glues is at least the **temperature**

Abstract tile assembly model

Tile assembly system:
tile set, seed tile, temperature

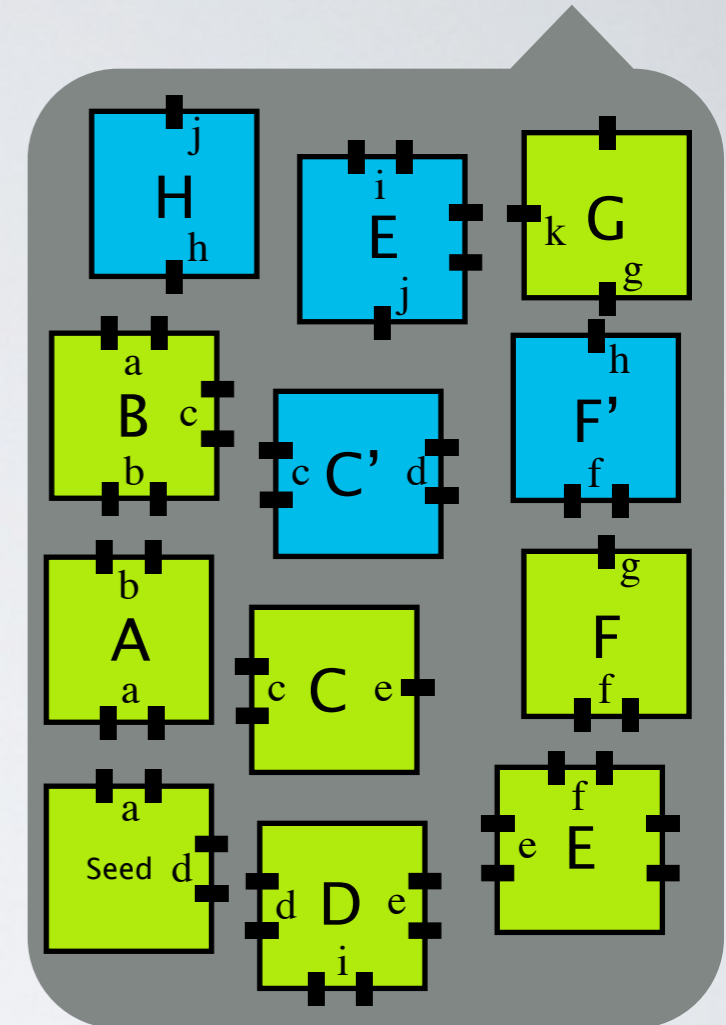
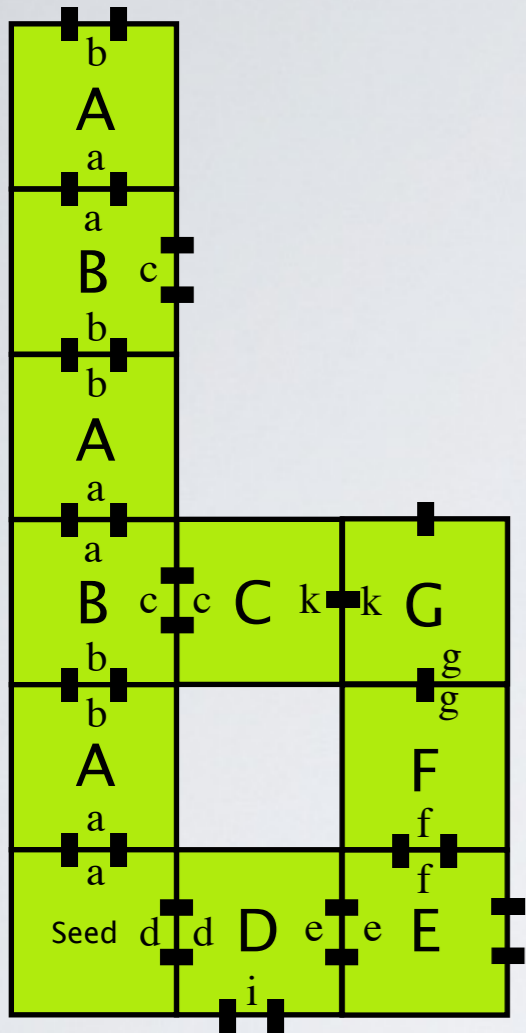

Temperature = 2

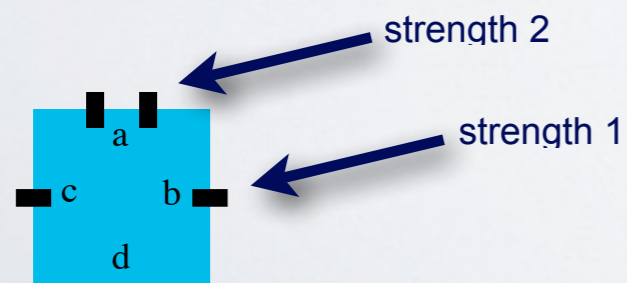

- Finite set of square **tiles**, each side has a **glue** and **strength**
- **Tile assembly system:** [tile set, seed tile, temperature (0,1,2,3,...)]
- Growth begins from the **seed** tile/assembly
- A tile **sticks** to an assembly if enough of its glues match so that the sum of the strengths of the matching glues is at least the **temperature**

Abstract tile assembly model

Tile assembly system:
tile set, seed tile, temperature

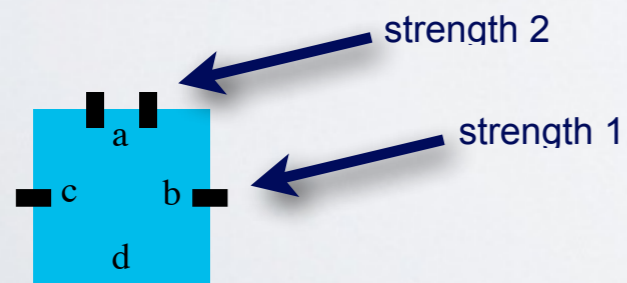
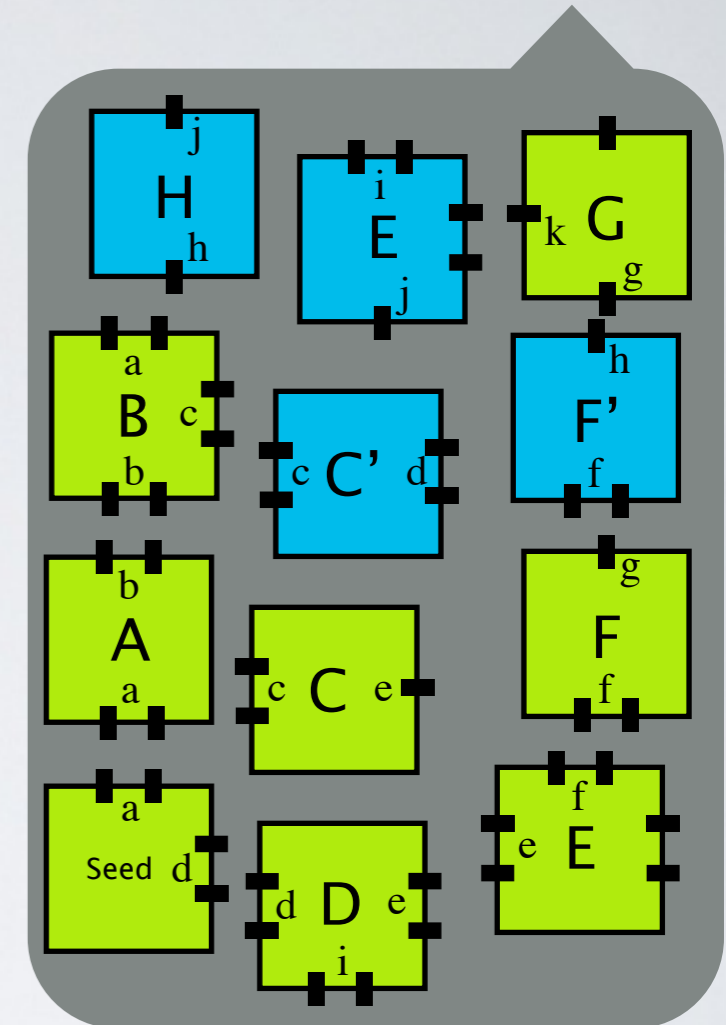
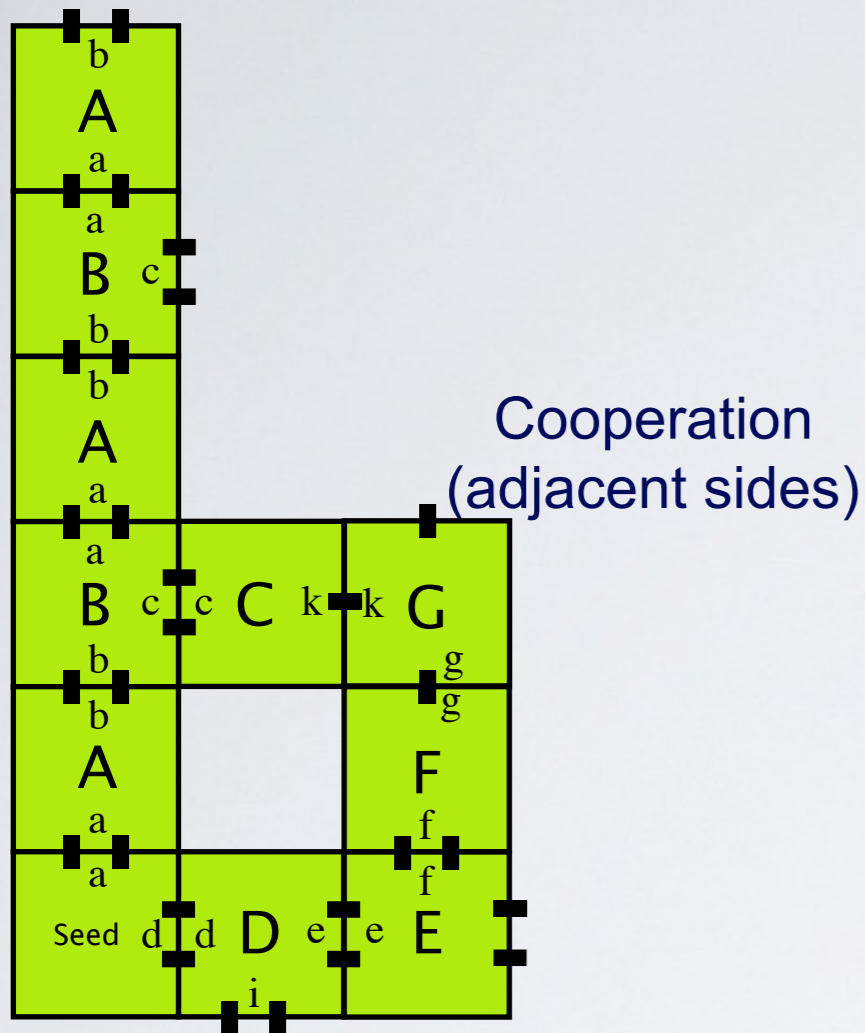

- Finite set of square **tiles**, each side has a **glue** and **strength**
- **Tile assembly system:** [tile set, seed tile, temperature (0,1,2,3,...)]
- Growth begins from the **seed** tile/assembly
- A tile **sticks** to an assembly if enough of its glues match so that the sum of the strengths of the matching glues is at least the **temperature**

Abstract tile assembly model

Tile assembly system:
tile set, seed tile, temperature

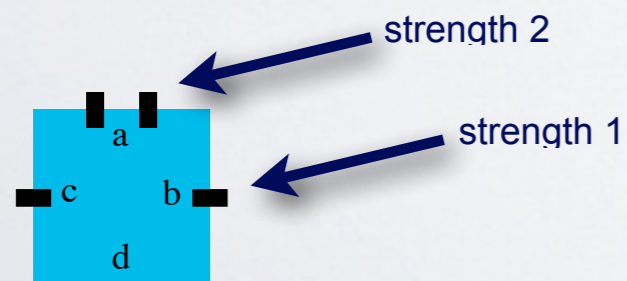
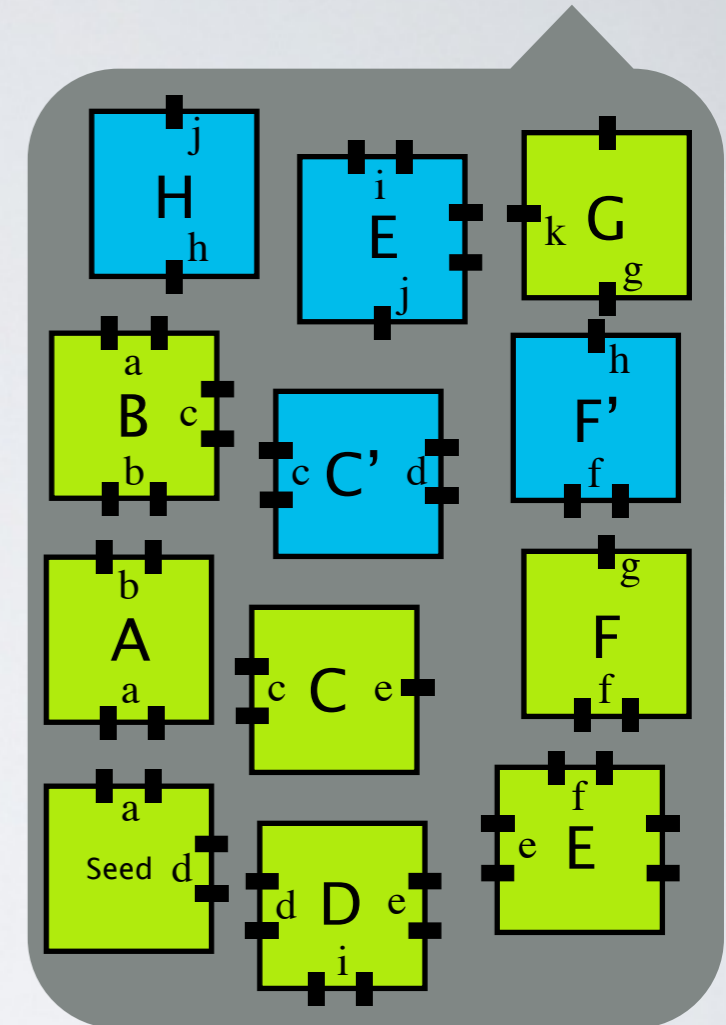
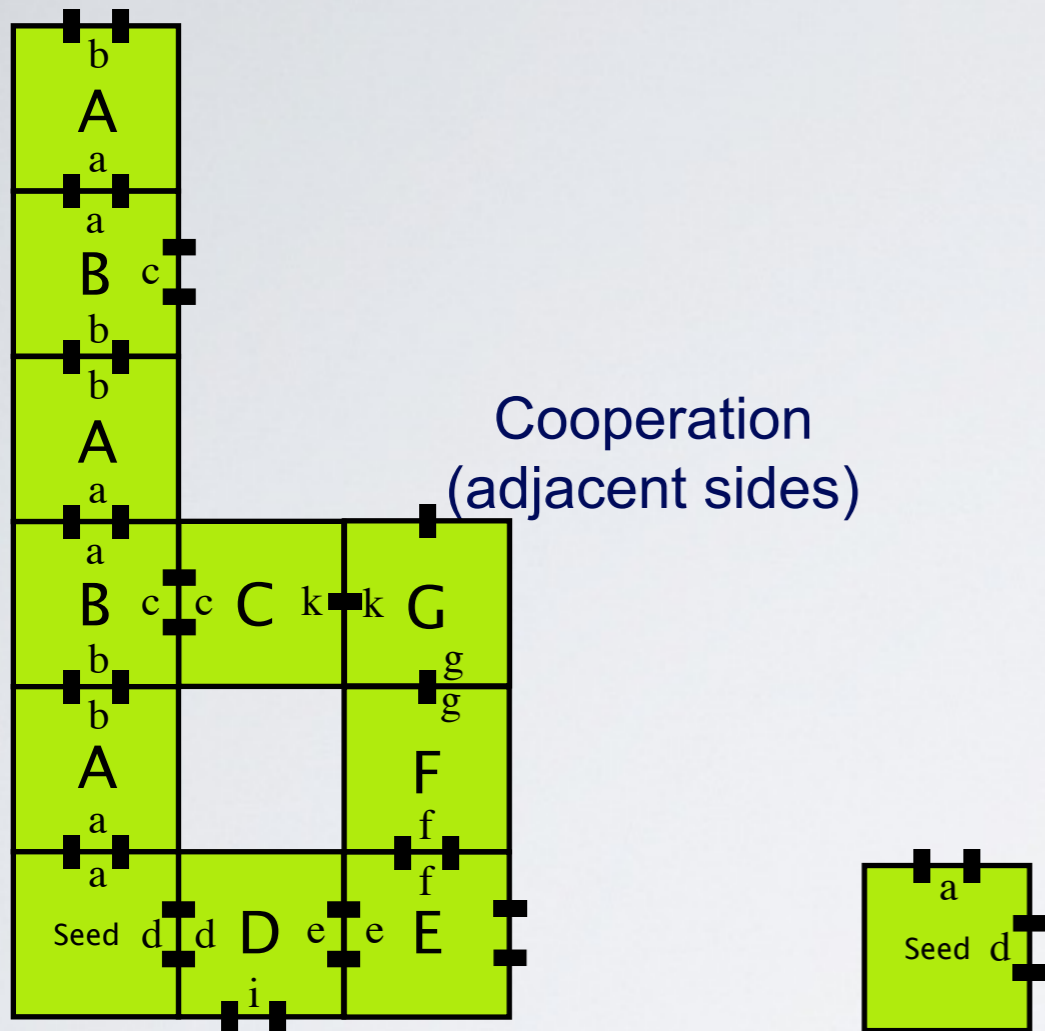

- Finite set of square **tiles**, each side has a **glue** and **strength**
- **Tile assembly system:** [tile set, seed tile, temperature (0,1,2,3,...)]
- Growth begins from the **seed** tile/assembly
- A tile **sticks** to an assembly if enough of its glues match so that the sum of the strengths of the matching glues is at least the **temperature**

Abstract tile assembly model

Tile assembly system:
tile set, seed tile, temperature

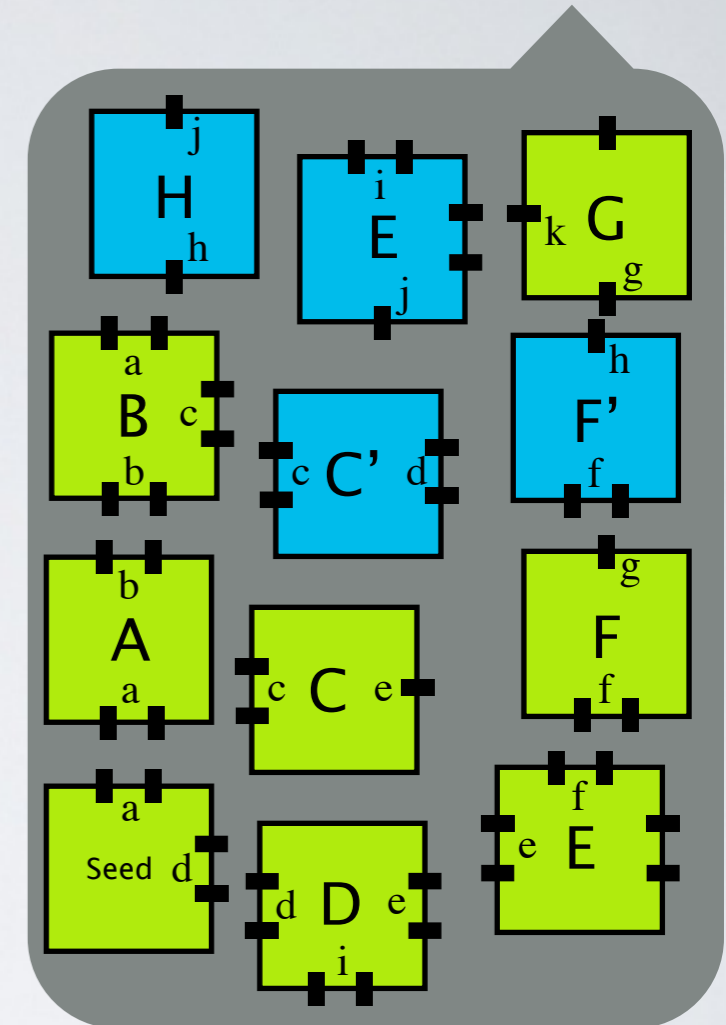
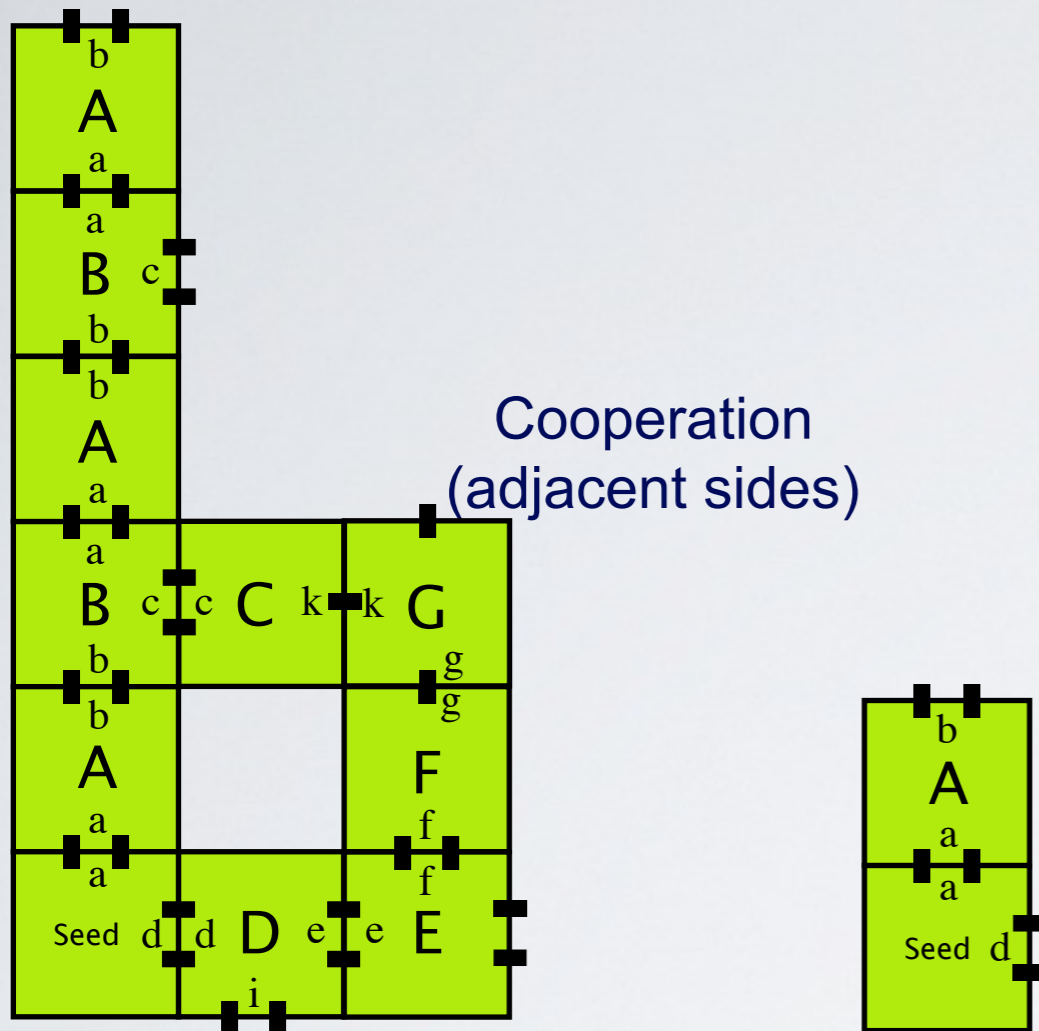

Temperature = 2

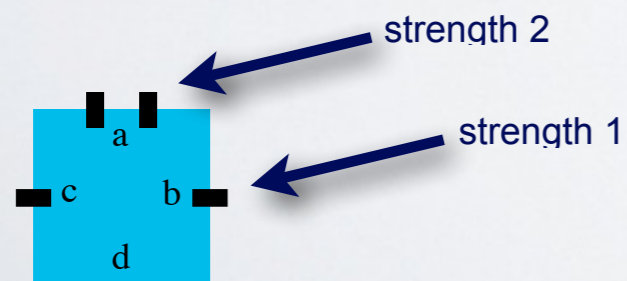

- Finite set of square **tiles**, each side has a **glue** and **strength**
- **Tile assembly system:** [tile set, seed tile, temperature (0,1,2,3,...)]
- Growth begins from the **seed** tile/assembly
- A tile **sticks** to an assembly if enough of its glues match so that the sum of the strengths of the matching glues is at least the **temperature**

Abstract tile assembly model

Tile assembly system:
tile set, seed tile, temperature

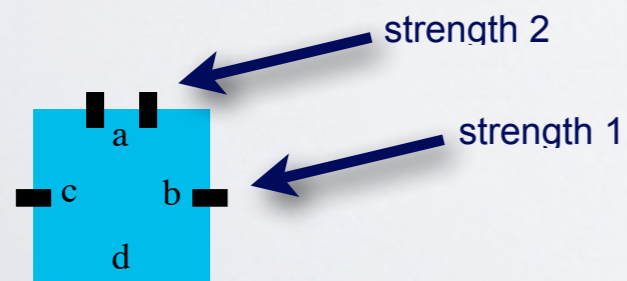
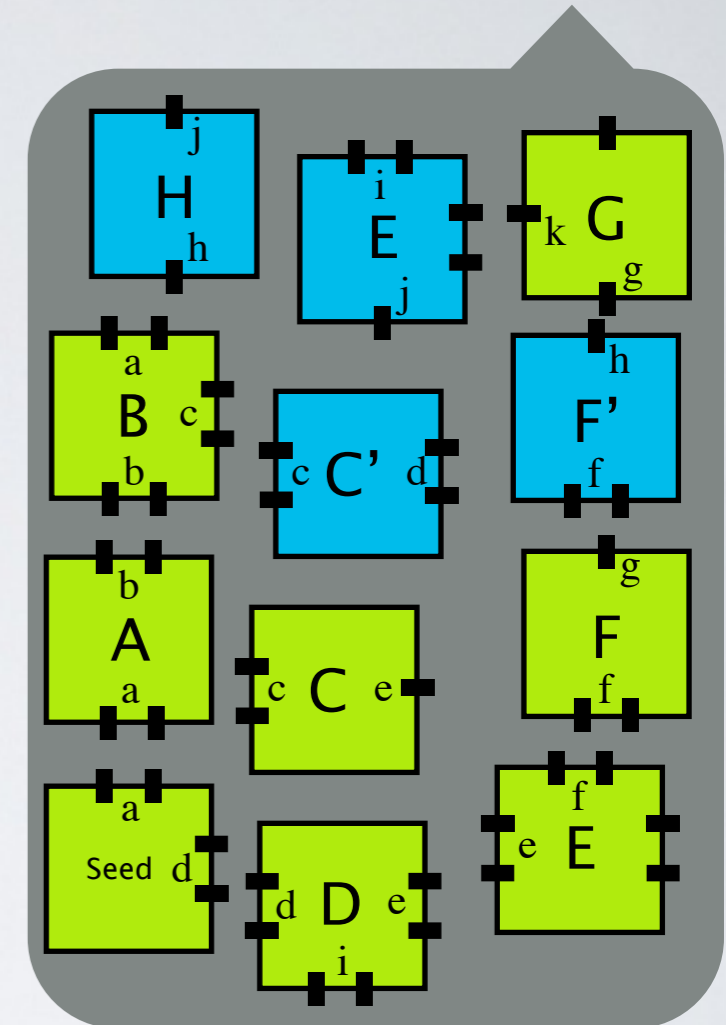
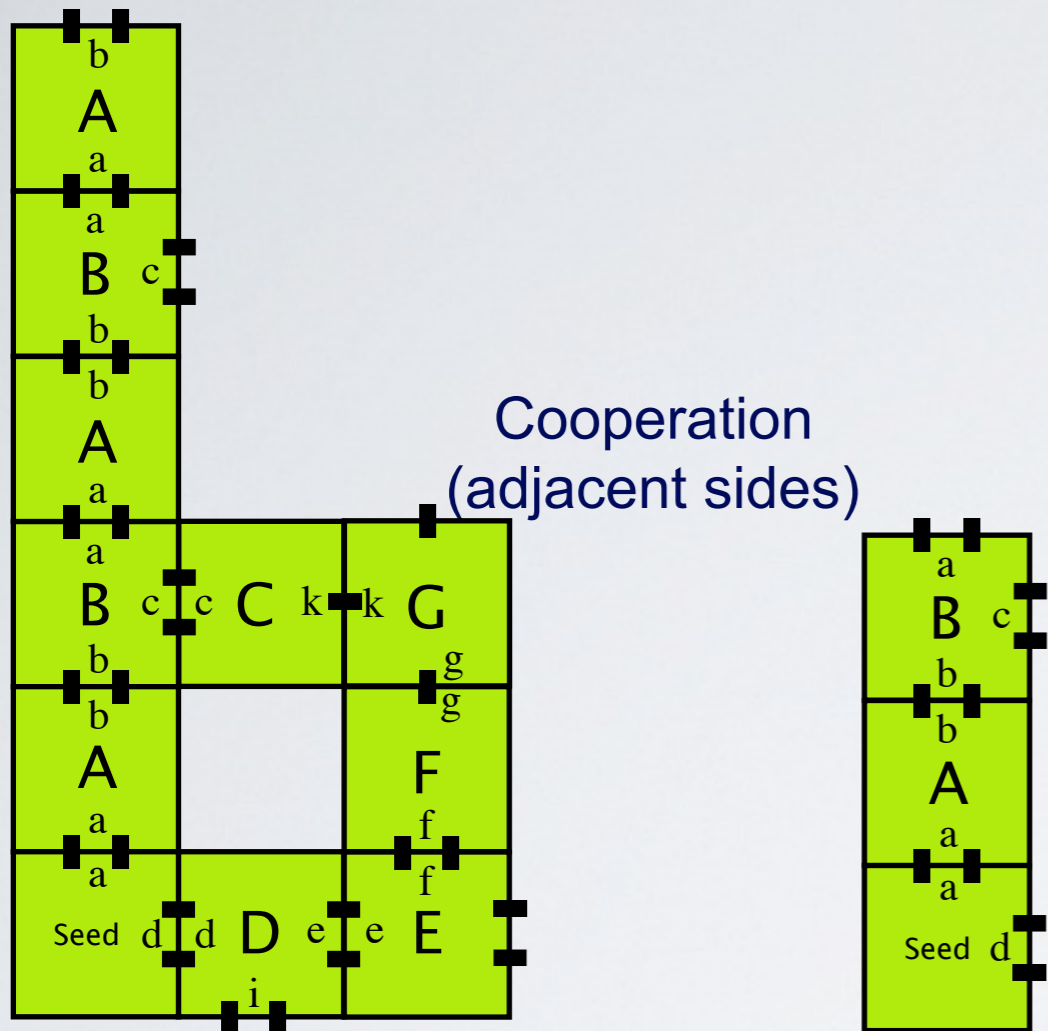

- Finite set of square **tiles**, each side has a **glue** and **strength**
- **Tile assembly system:** [tile set, seed tile, temperature (0,1,2,3,...)]
- Growth begins from the **seed** tile/assembly
- A tile **sticks** to an assembly if enough of its glues match so that the sum of the strengths of the matching glues is at least the **temperature**

Abstract tile assembly model

Tile assembly system:
tile set, seed tile, temperature

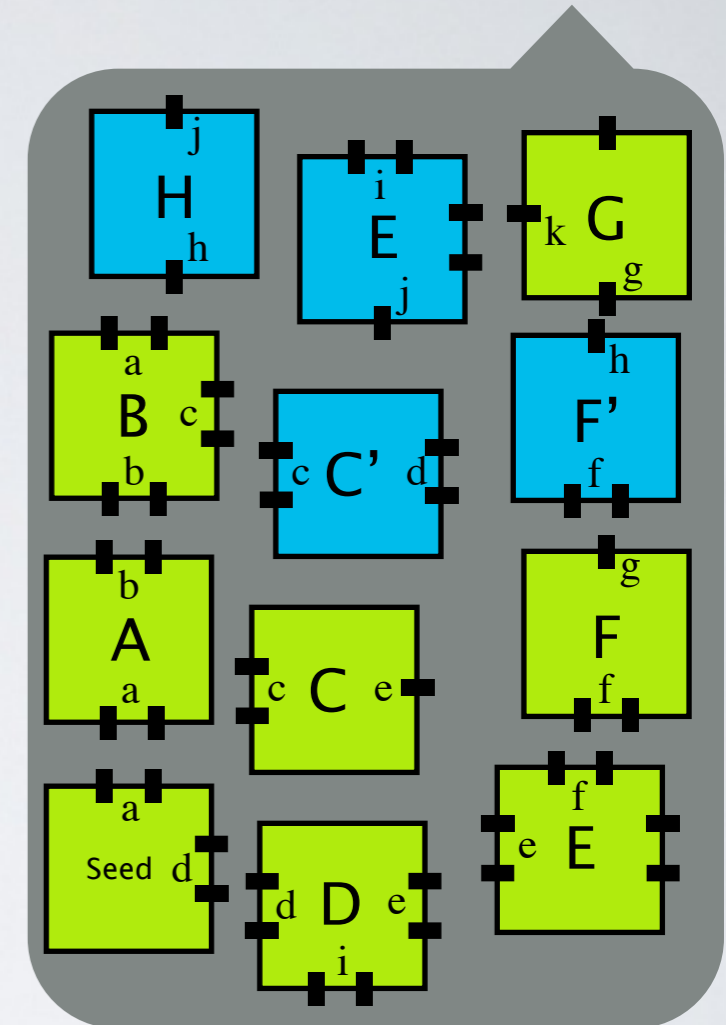
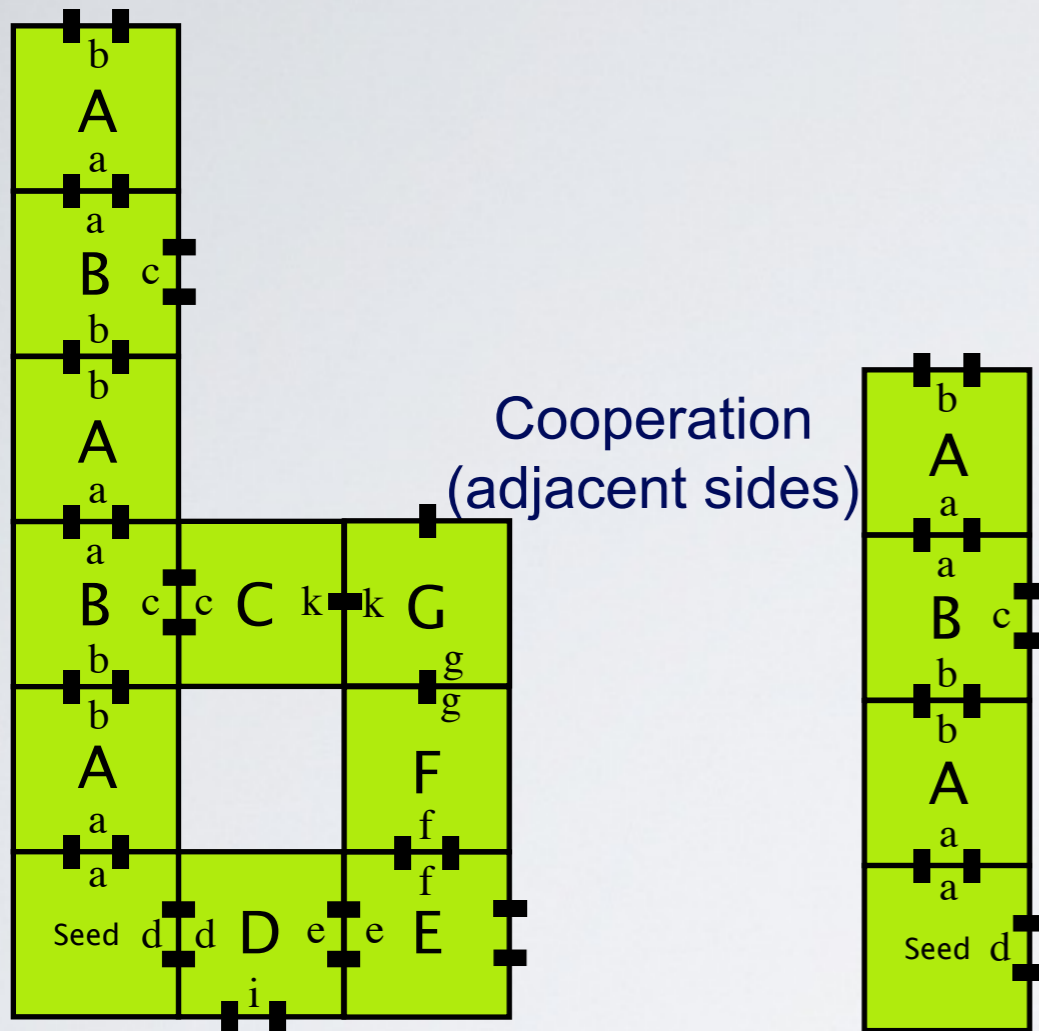

Temperature = 2

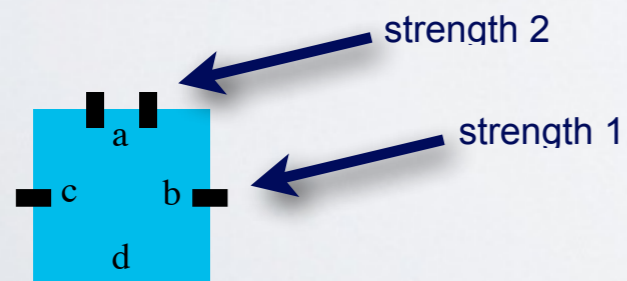

- Finite set of square **tiles**, each side has a **glue** and **strength**
- **Tile assembly system:** [tile set, seed tile, temperature (0,1,2,3,...)]
- Growth begins from the **seed** tile/assembly
- A tile **sticks** to an assembly if enough of its glues match so that the sum of the strengths of the matching glues is at least the **temperature**

Abstract tile assembly model

Tile assembly system:
tile set, seed tile, temperature

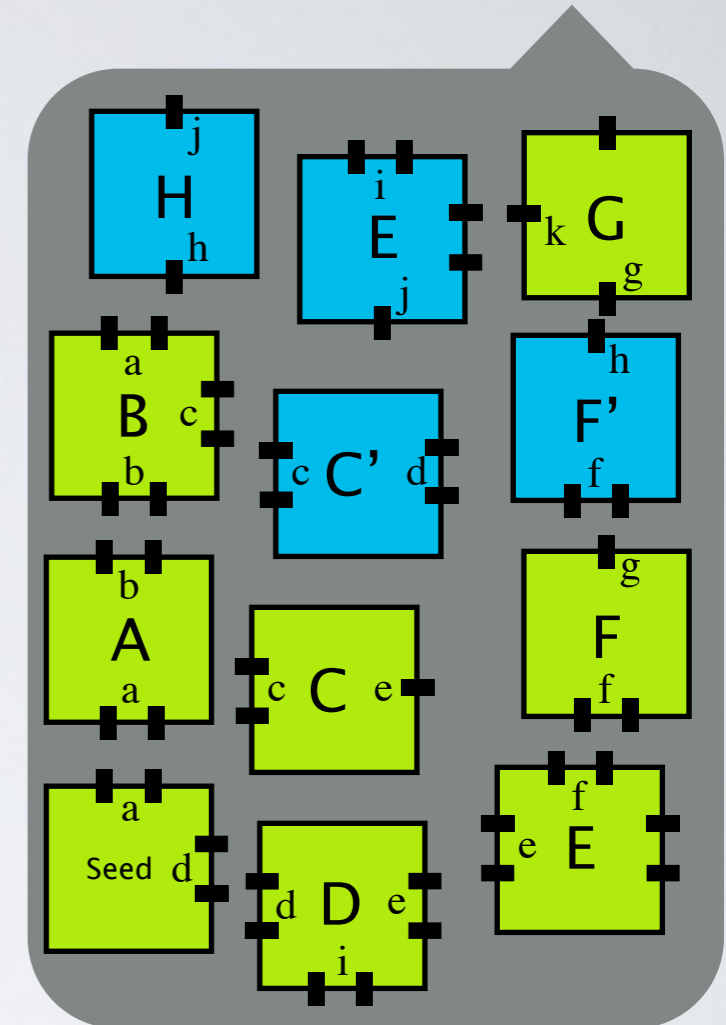
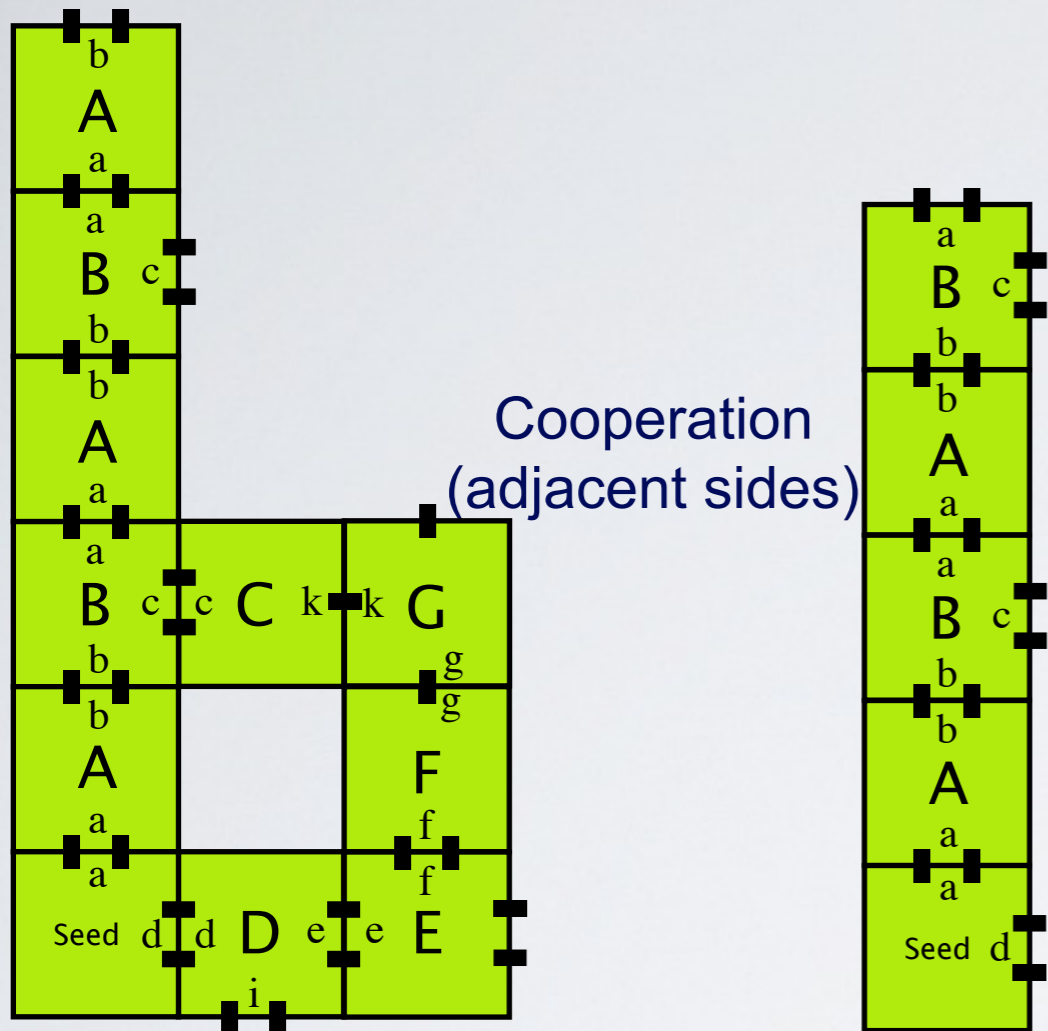

Temperature = 2

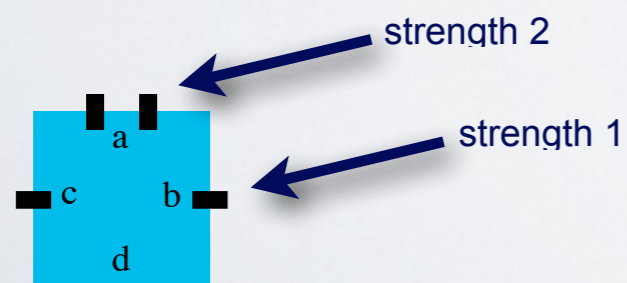

- Finite set of square **tiles**, each side has a **glue** and **strength**
- **Tile assembly system:** [tile set, seed tile, temperature (0,1,2,3,...)]
- Growth begins from the **seed** tile/assembly
- A tile **sticks** to an assembly if enough of its glues match so that the sum of the strengths of the matching glues is at least the **temperature**

Abstract tile assembly model

Tile assembly system:
tile set, seed tile, temperature

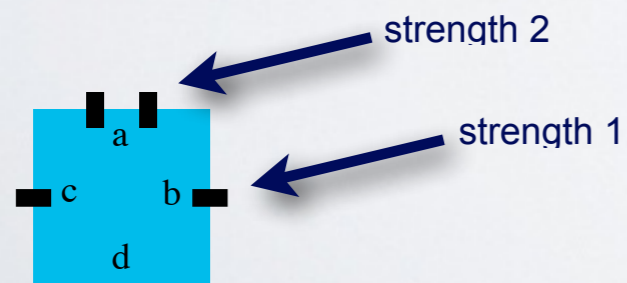
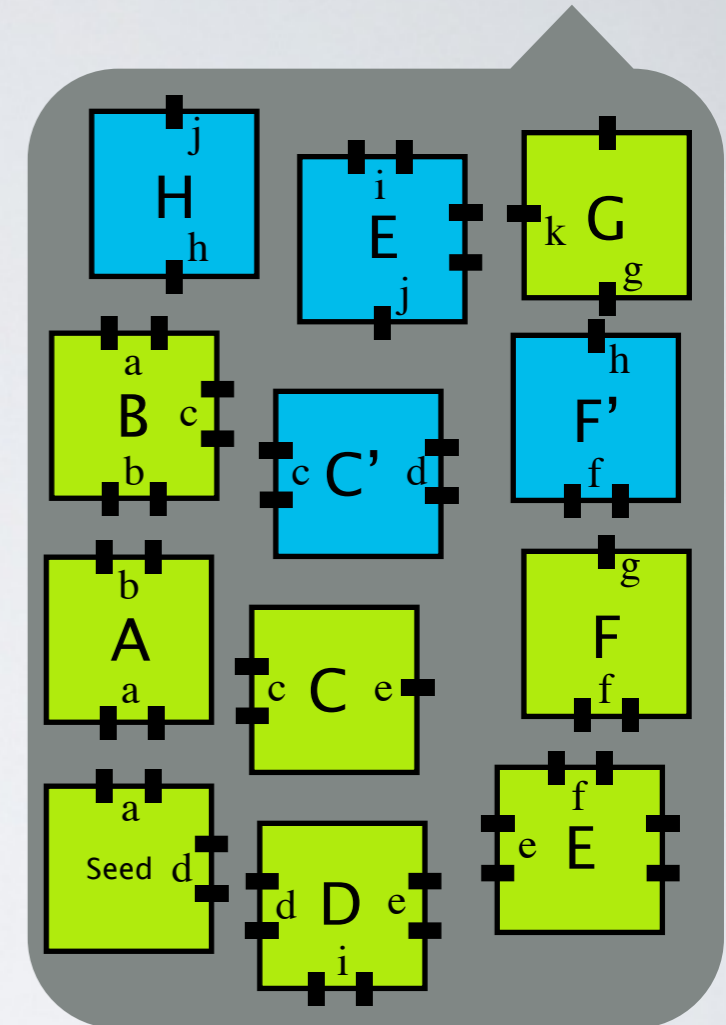
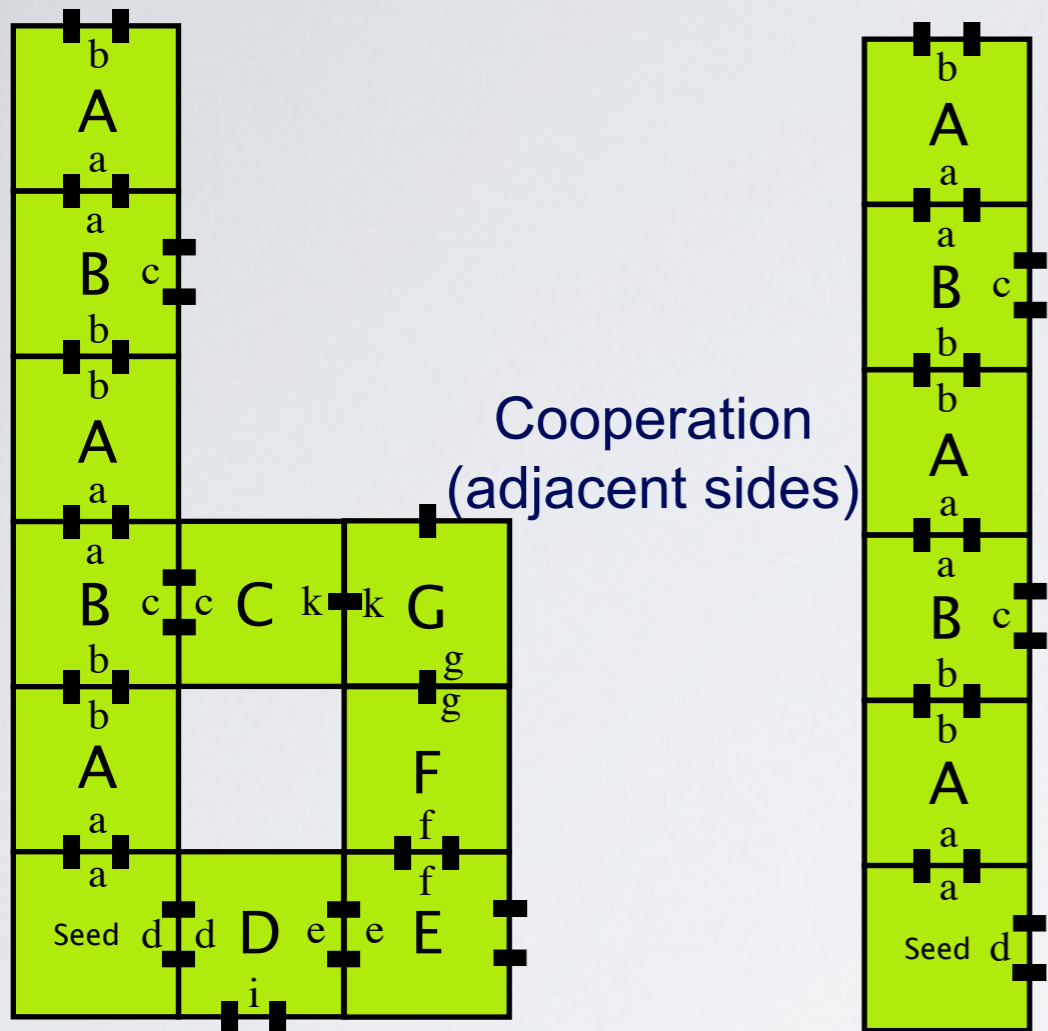

- Finite set of square **tiles**, each side has a **glue** and **strength**
- **Tile assembly system:** [tile set, seed tile, temperature (0,1,2,3,...)]
- Growth begins from the **seed** tile/assembly
- A tile **sticks** to an assembly if enough of its glues match so that the sum of the strengths of the matching glues is at least the **temperature**

Abstract tile assembly model

Tile assembly system:
tile set, seed tile, temperature

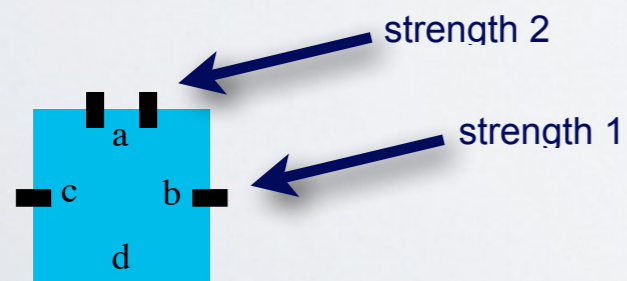
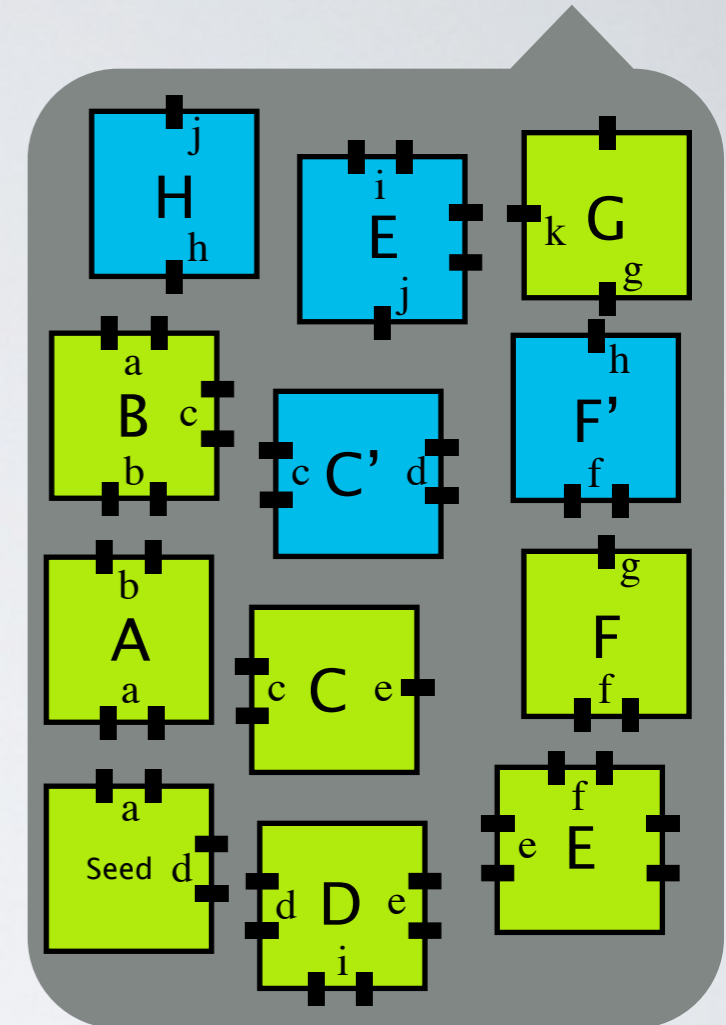
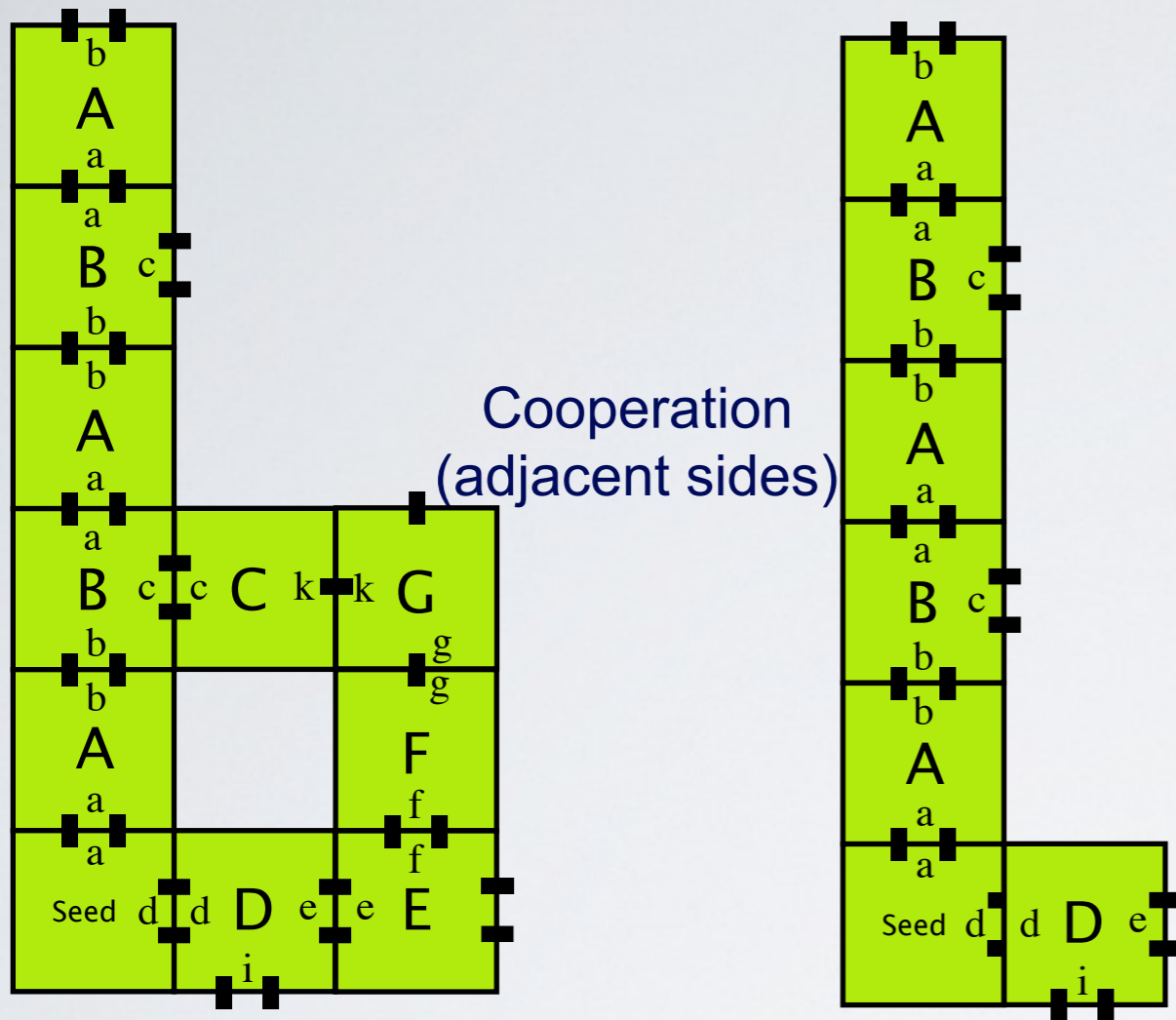

- Finite set of square **tiles**, each side has a **glue** and **strength**
- **Tile assembly system:** [tile set, seed tile, temperature (0,1,2,3,...)]
- Growth begins from the **seed** tile/assembly
- A tile **sticks** to an assembly if enough of its glues match so that the sum of the strengths of the matching glues is at least the **temperature**

Abstract tile assembly model

Tile assembly system:
tile set, seed tile, temperature

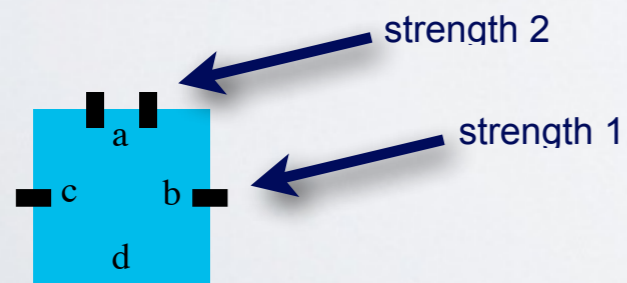
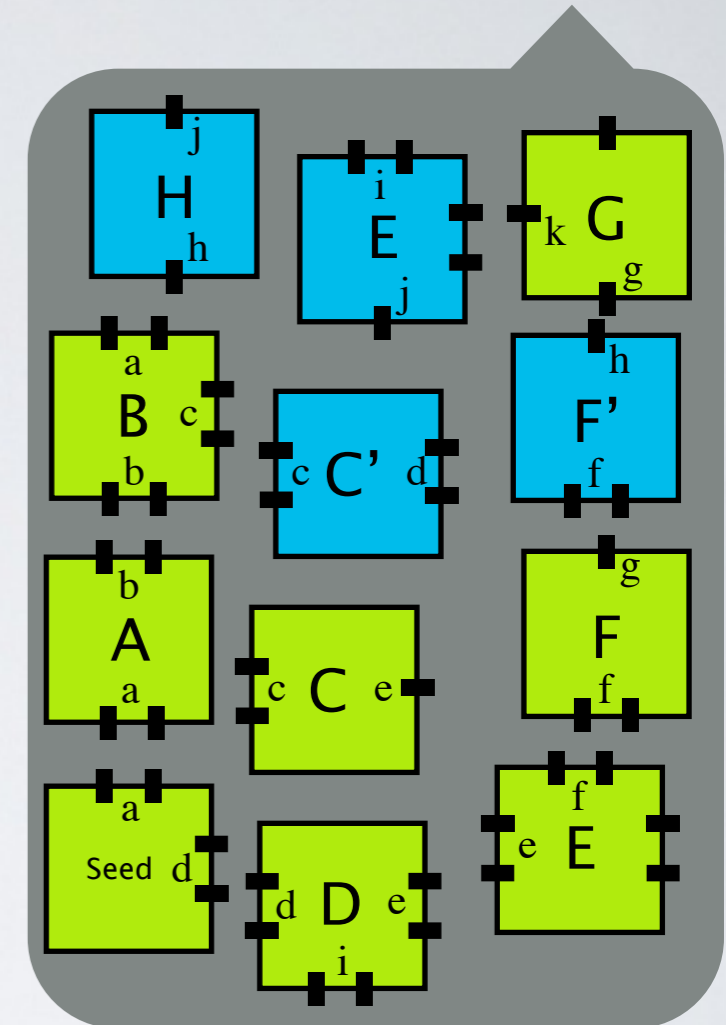
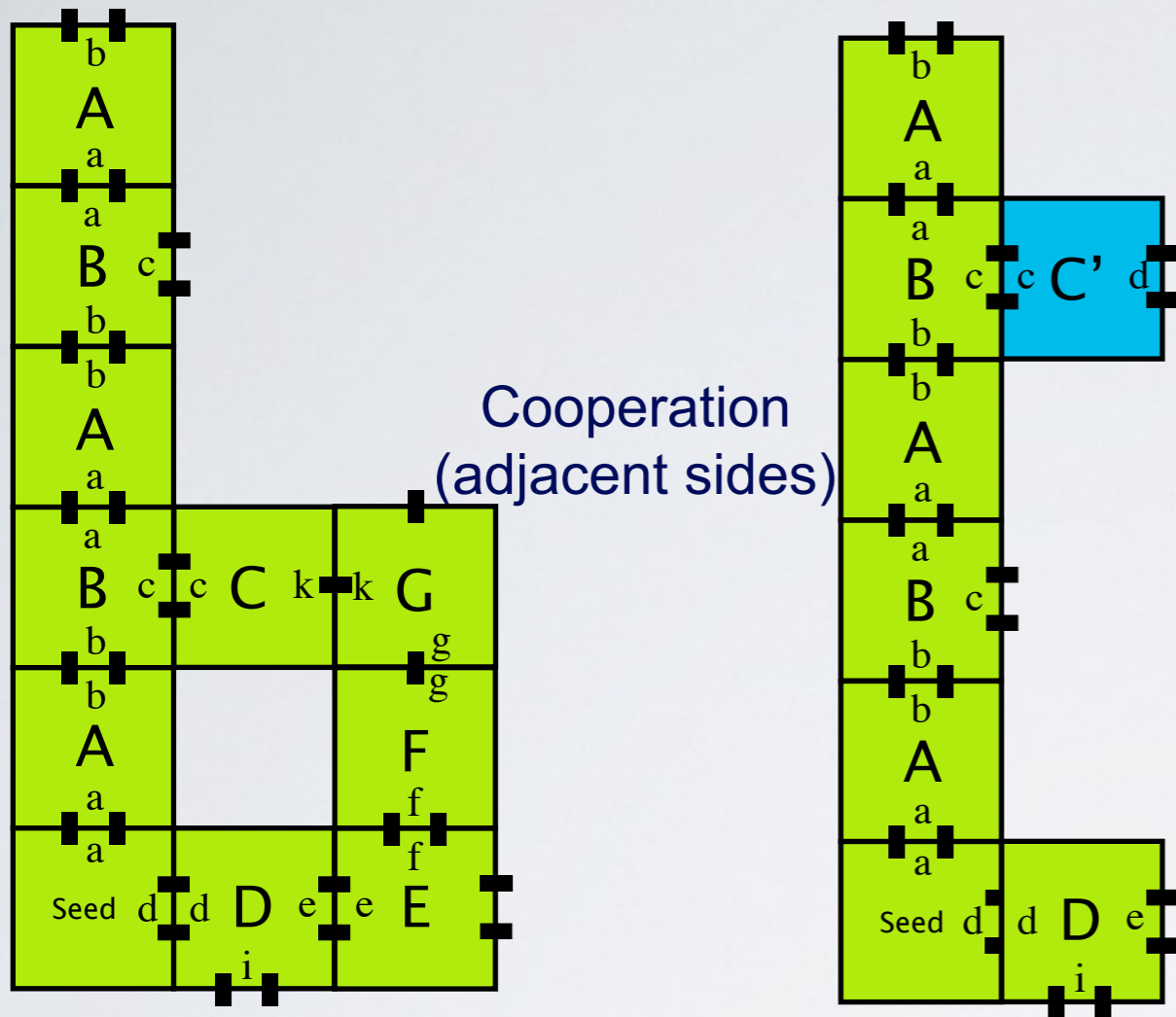

- Finite set of square **tiles**, each side has a **glue** and **strength**
- **Tile assembly system:** [tile set, seed tile, temperature (0,1,2,3,...)]
- Growth begins from the **seed** tile/assembly
- A tile **sticks** to an assembly if enough of its glues match so that the sum of the strengths of the matching glues is at least the **temperature**

Abstract tile assembly model

Tile assembly system:
tile set, seed tile, temperature

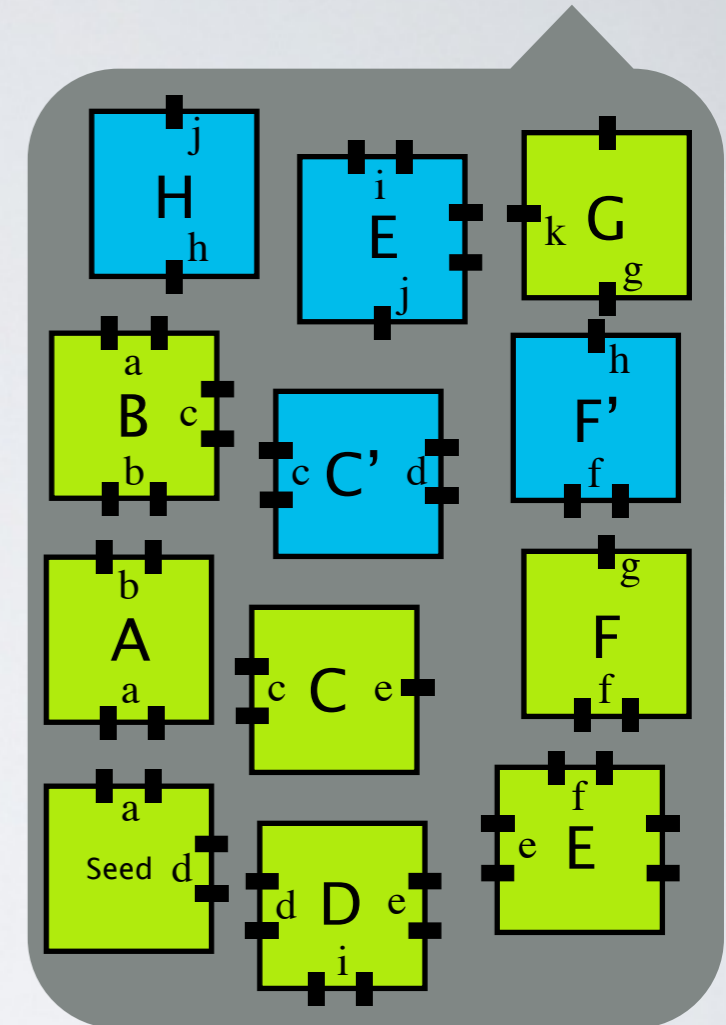
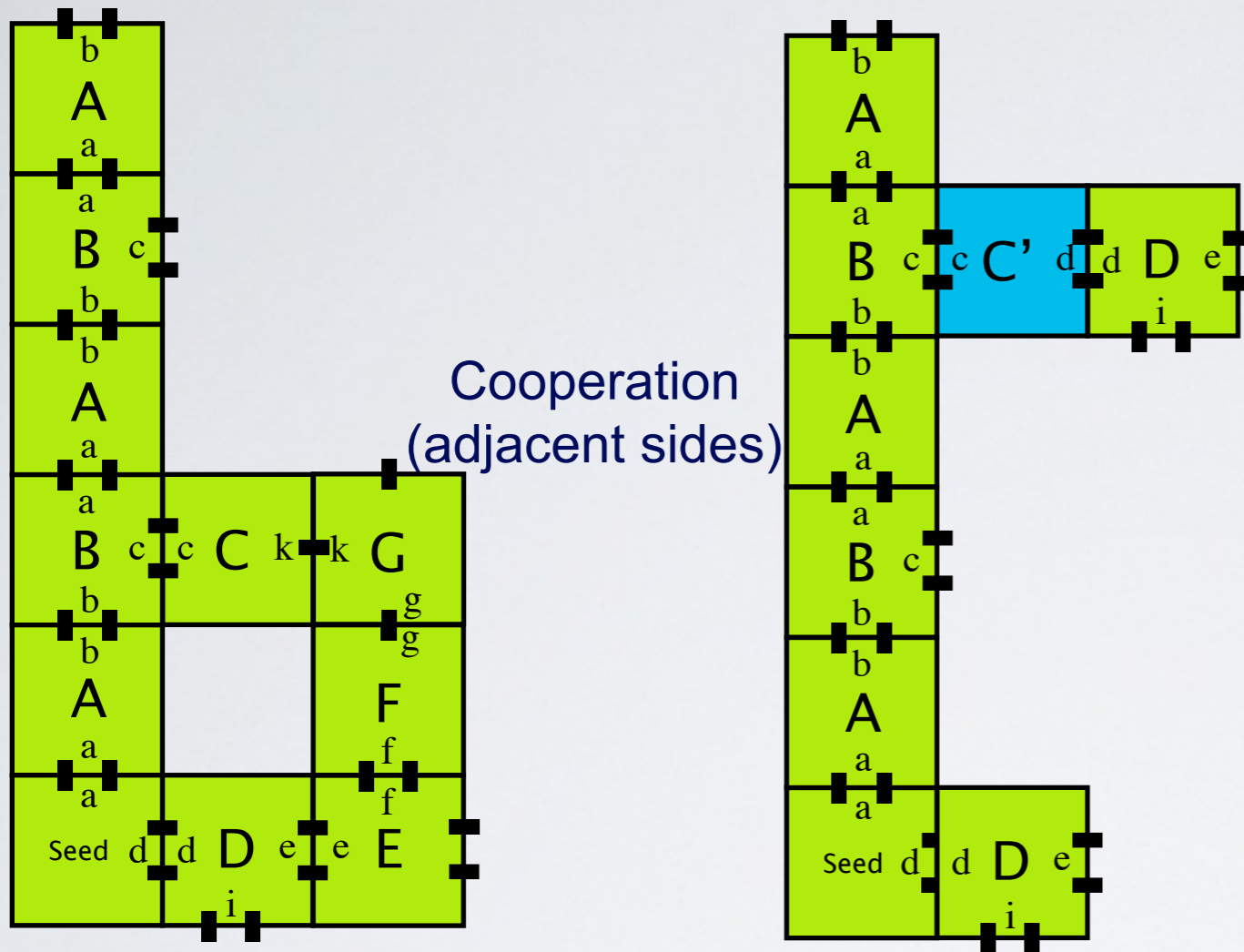

Temperature = 2

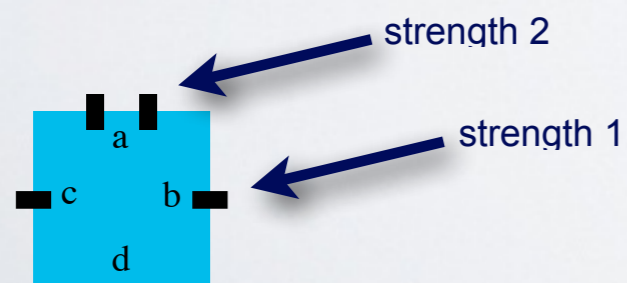

- Finite set of square **tiles**, each side has a **glue** and **strength**
- **Tile assembly system:** [tile set, seed tile, temperature (0,1,2,3,...)]
- Growth begins from the **seed** tile/assembly
- A tile **sticks** to an assembly if enough of its glues match so that the sum of the strengths of the matching glues is at least the **temperature**

Abstract tile assembly model

Tile assembly system:
tile set, seed tile, temperature

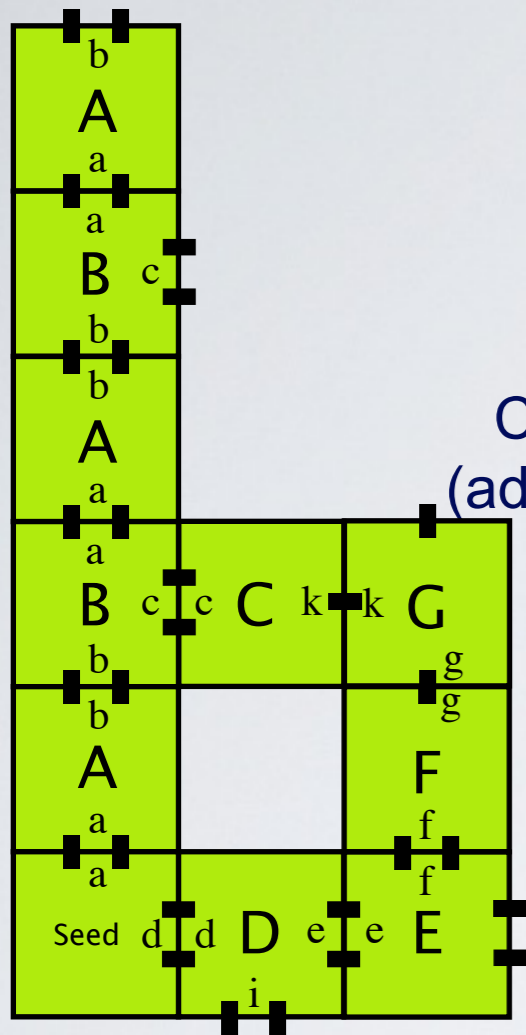

Cooperation
(adjacent sides)

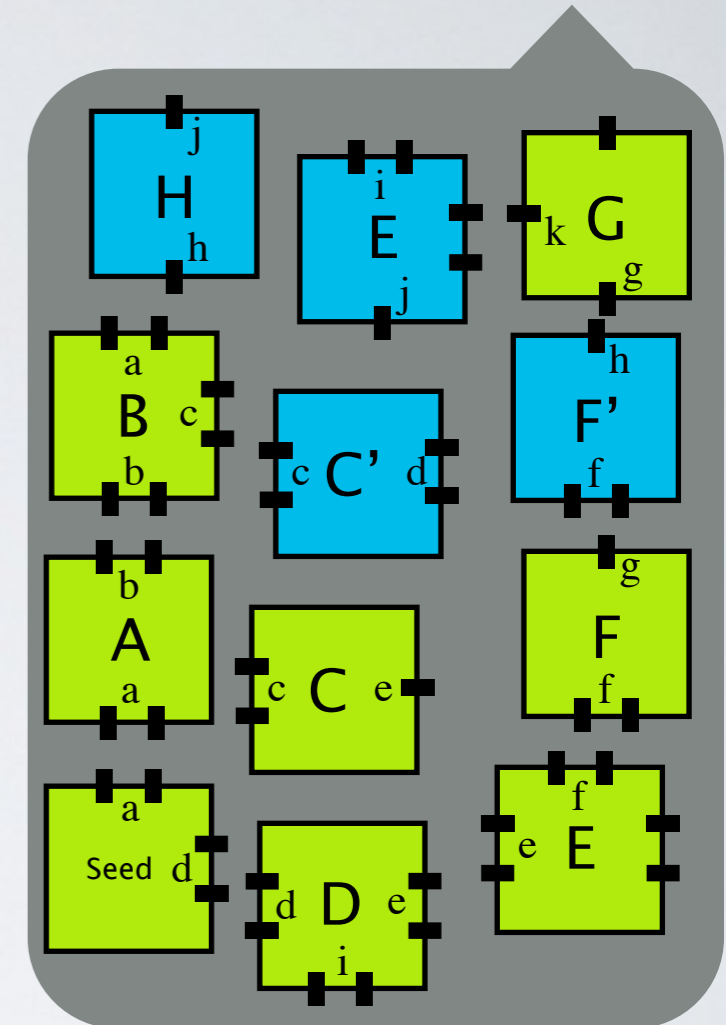
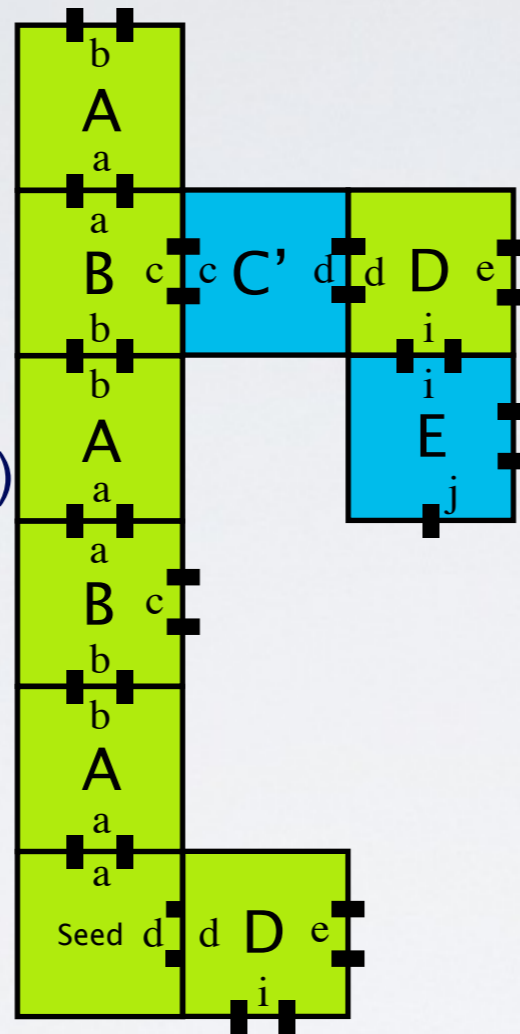

Temperature = 2

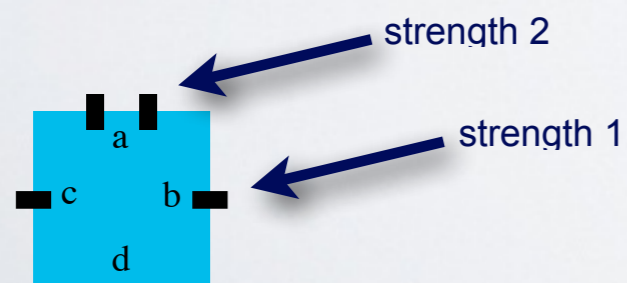

- Finite set of square **tiles**, each side has a **glue** and **strength**
- **Tile assembly system:** [tile set, seed tile, temperature (0,1,2,3,...)]
- Growth begins from the **seed** tile/assembly
- A tile **sticks** to an assembly if enough of its glues match so that the sum of the strengths of the matching glues is at least the **temperature**

Abstract tile assembly model

Tile assembly system:
tile set, seed tile, temperature

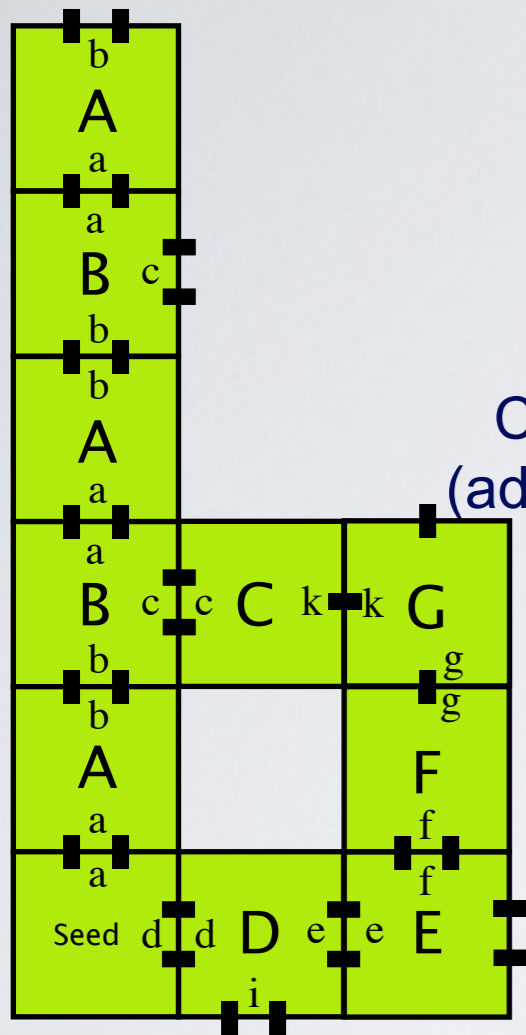

Cooperation
(adjacent sides)

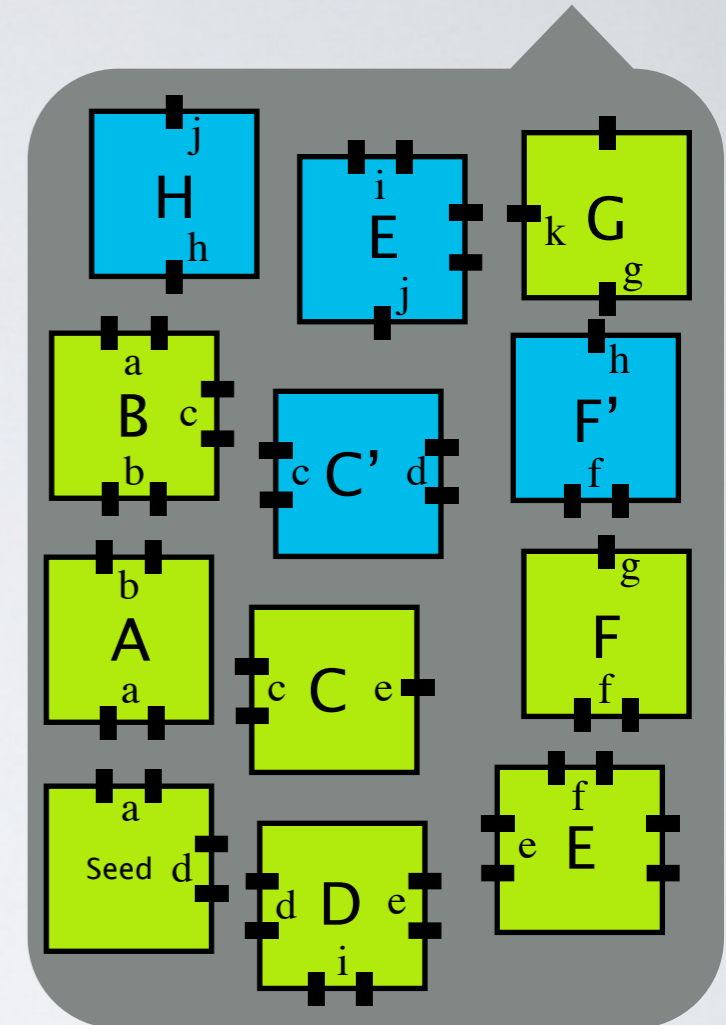
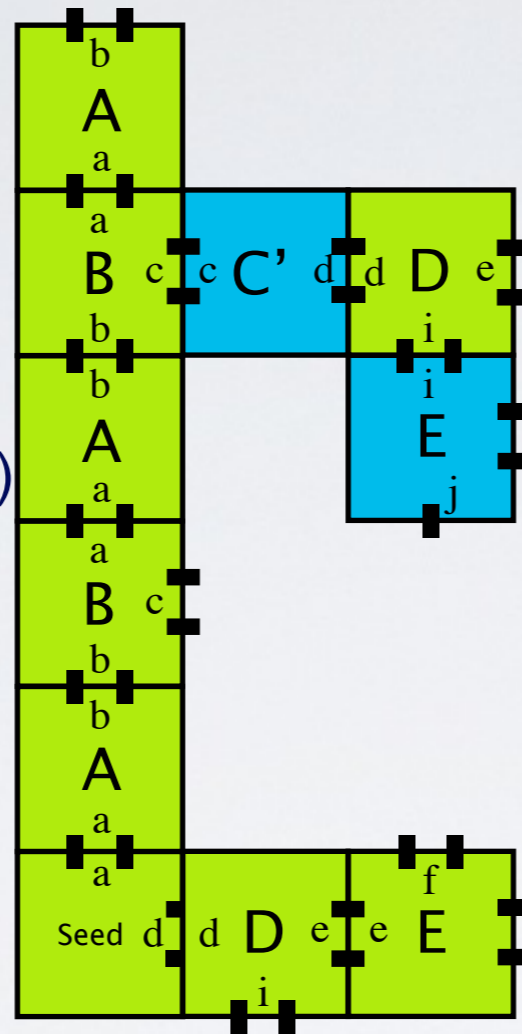

Temperature = 2

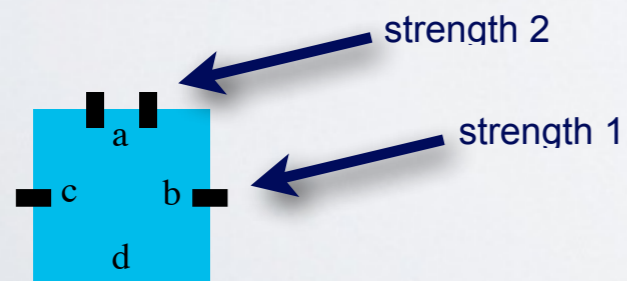

- Finite set of square **tiles**, each side has a **glue** and **strength**
- **Tile assembly system:** [tile set, seed tile, temperature (0,1,2,3,...)]
- Growth begins from the **seed** tile/assembly
- A tile **sticks** to an assembly if enough of its glues match so that the sum of the strengths of the matching glues is at least the **temperature**

Abstract tile assembly model

Tile assembly system:
tile set, seed tile, temperature

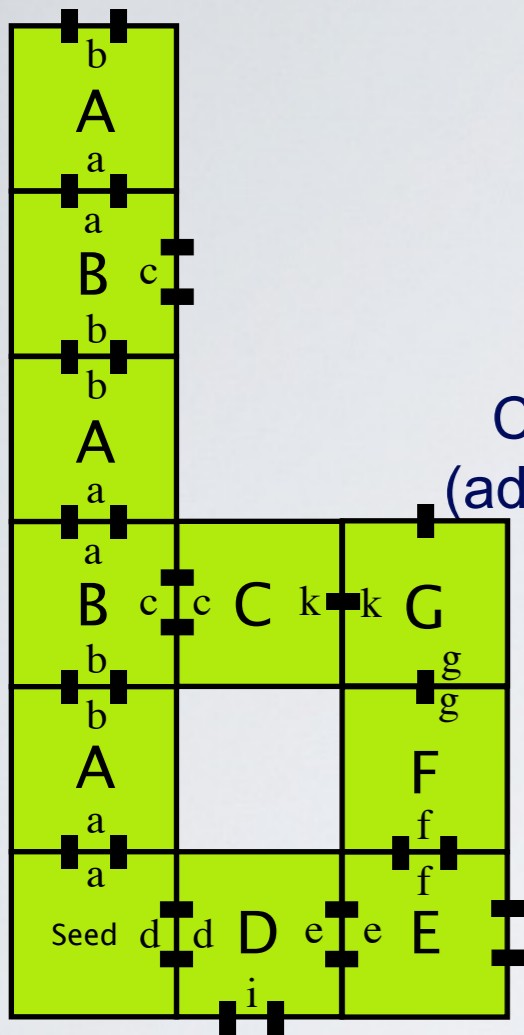

Cooperation
(adjacent sides)

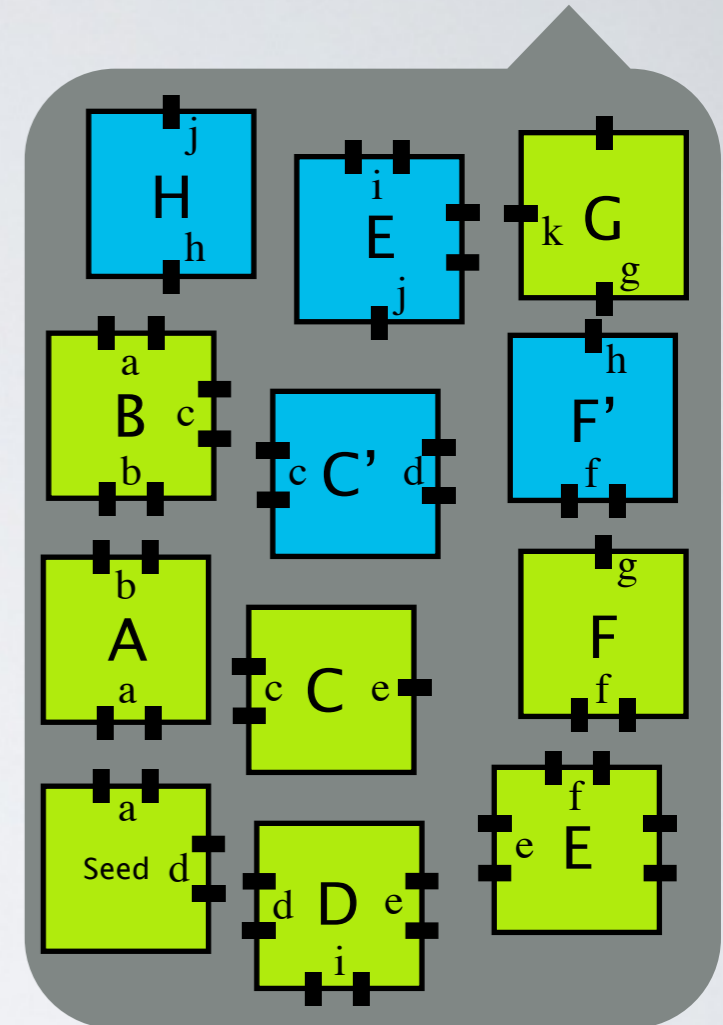
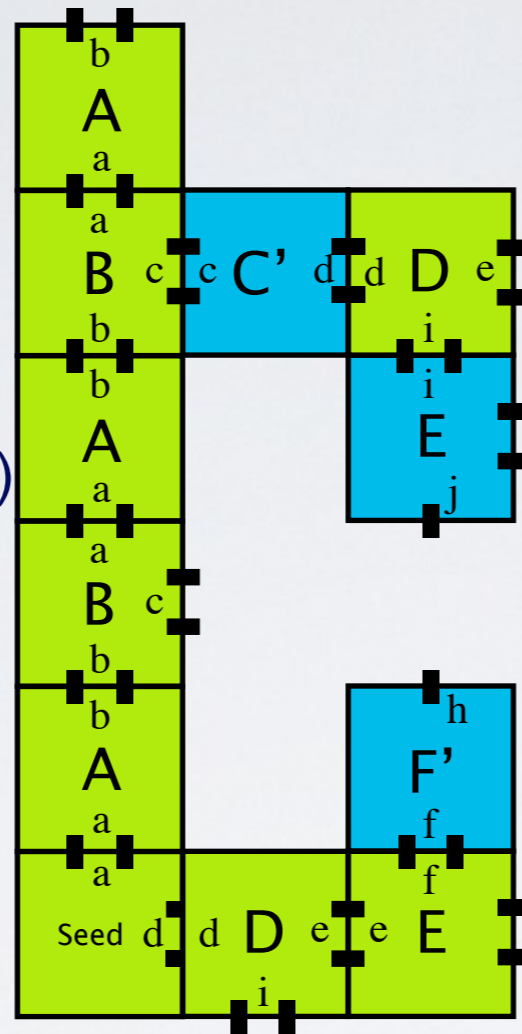

Temperature = 2

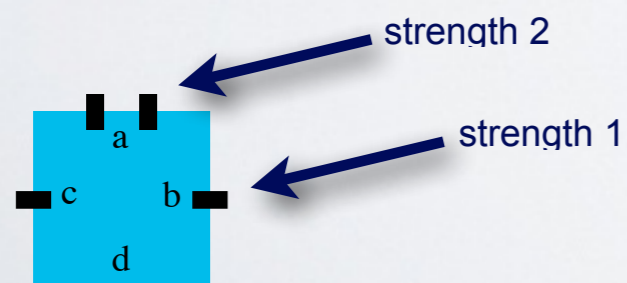

- Finite set of square **tiles**, each side has a **glue** and **strength**
- **Tile assembly system:** [tile set, seed tile, temperature (0,1,2,3,...)]
- Growth begins from the **seed** tile/assembly
- A tile **sticks** to an assembly if enough of its glues match so that the sum of the strengths of the matching glues is at least the **temperature**

Abstract tile assembly model

Tile assembly system:
tile set, seed tile, temperature

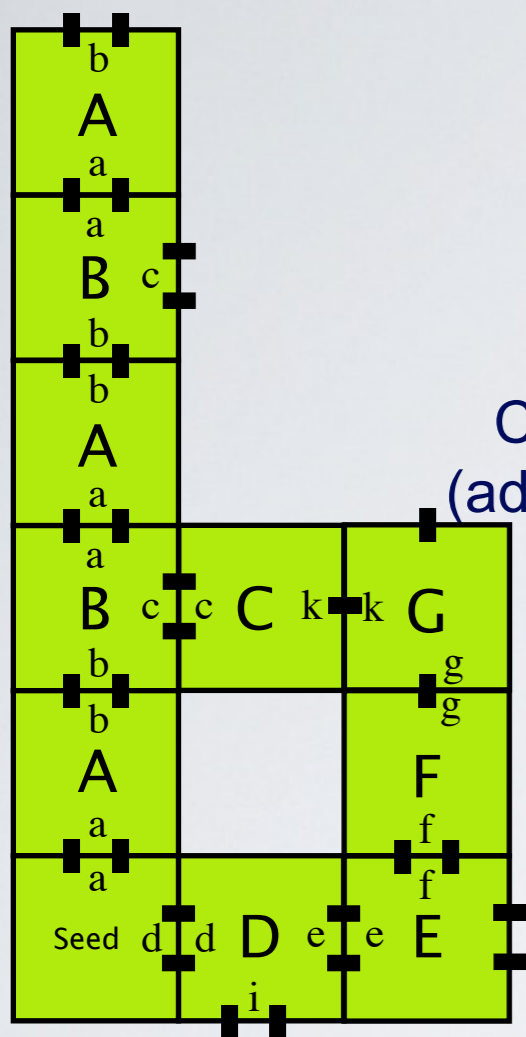

Cooperation
(adjacent sides)

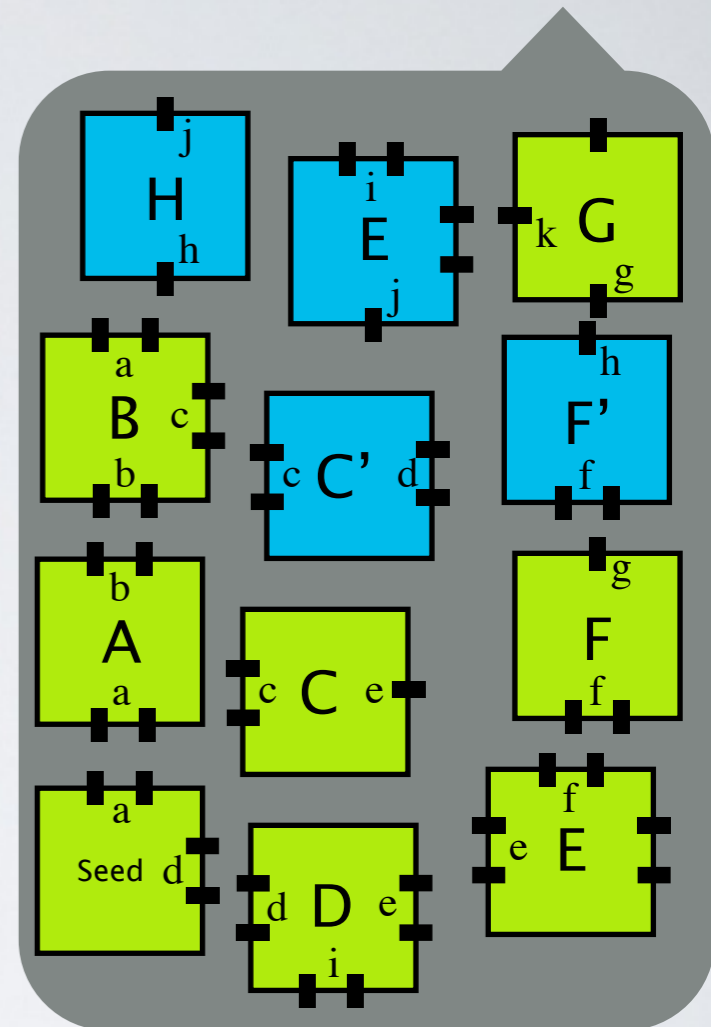
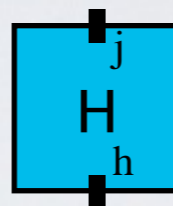
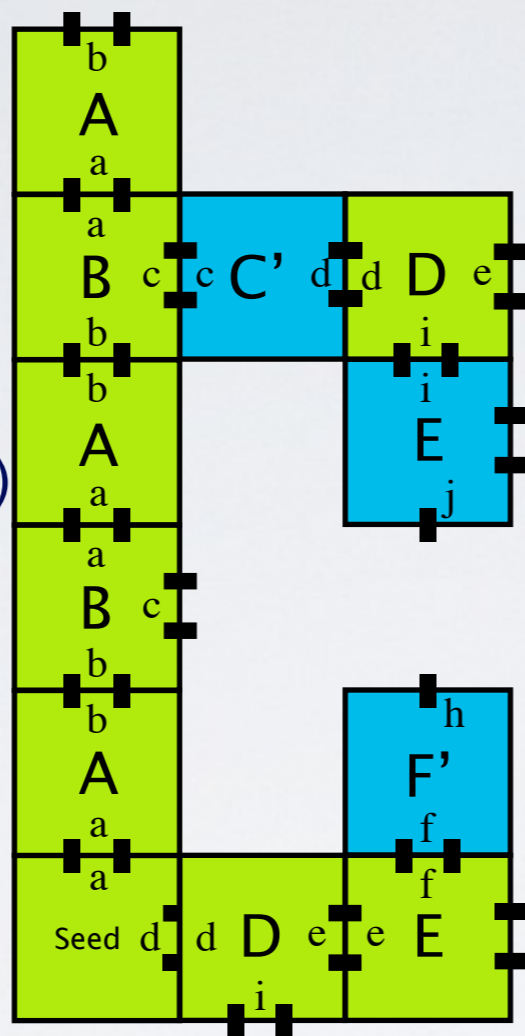

Temperature = 2

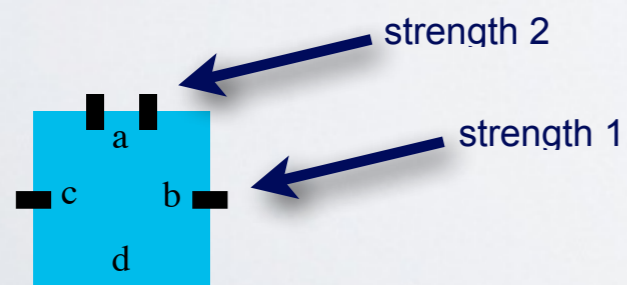

- Finite set of square **tiles**, each side has a **glue** and **strength**
- **Tile assembly system:** [tile set, seed tile, temperature (0,1,2,3,...)]
- Growth begins from the **seed** tile/assembly
- A tile **sticks** to an assembly if enough of its glues match so that the sum of the strengths of the matching glues is at least the **temperature**

Abstract tile assembly model

Tile assembly system:
tile set, seed tile, temperature

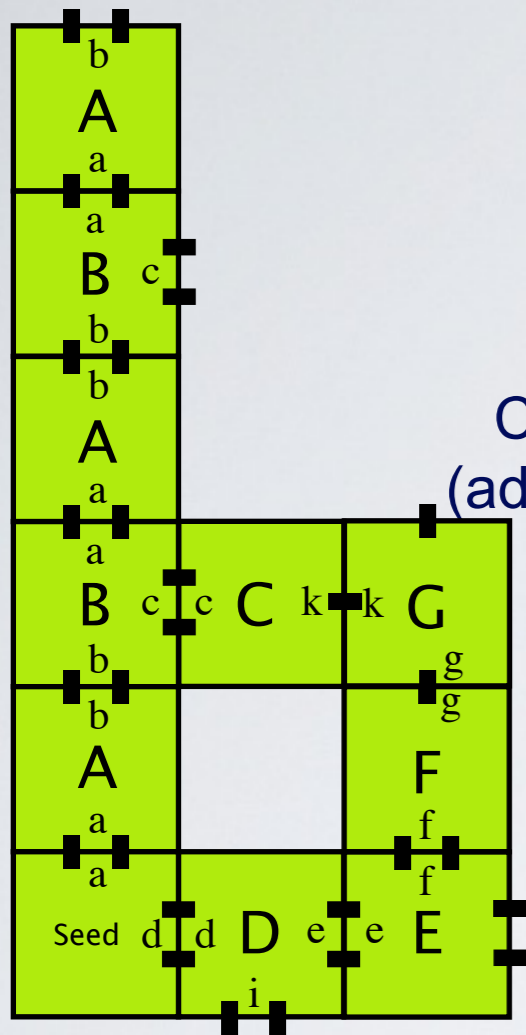

Cooperation
(adjacent sides)

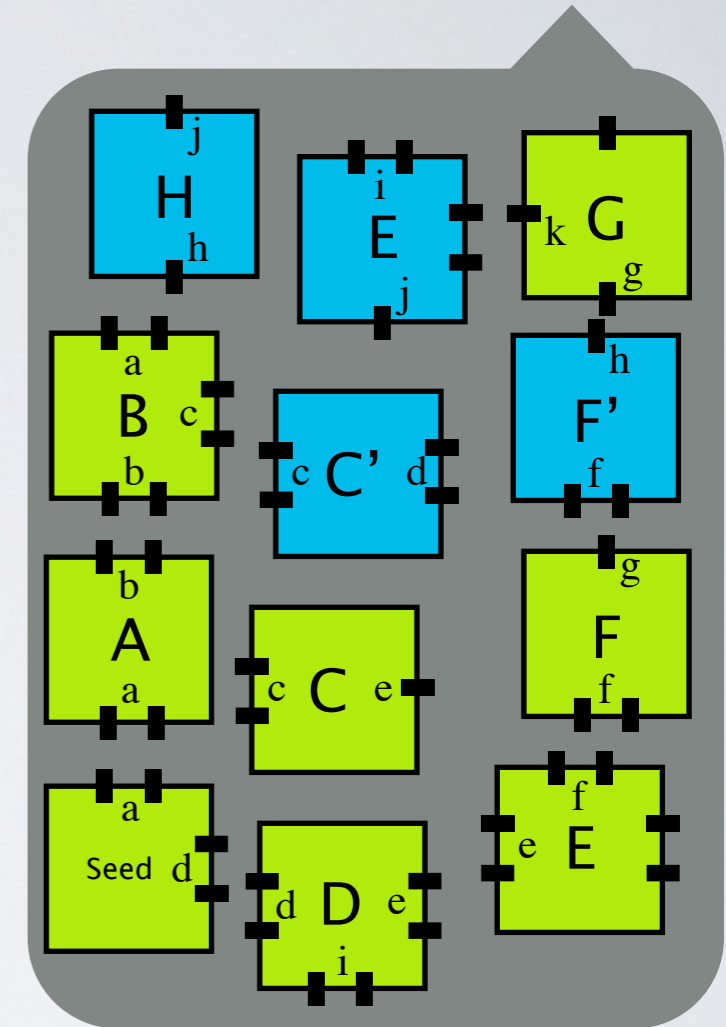
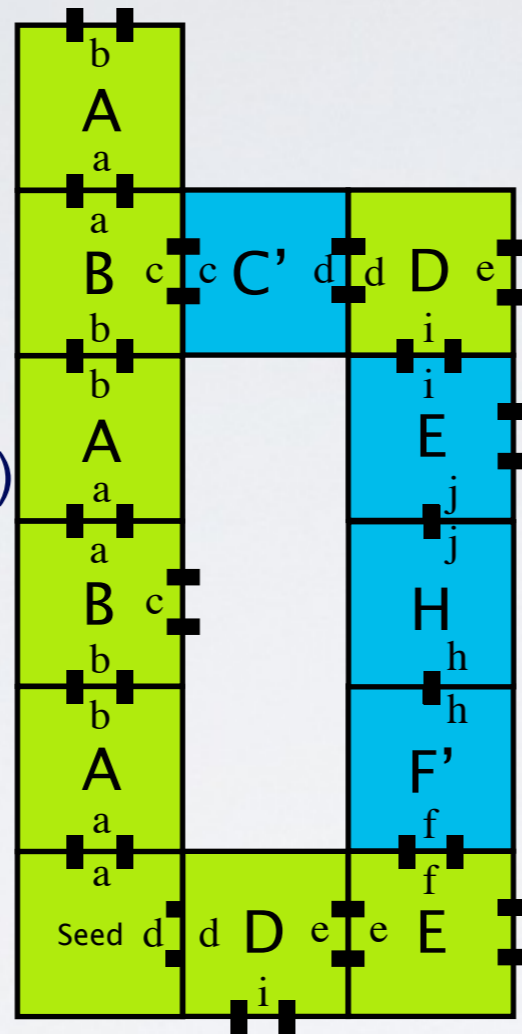

Temperature = 2

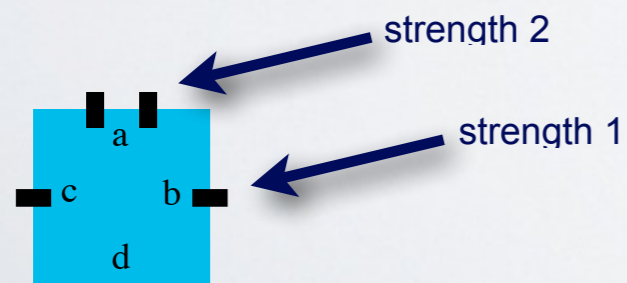

- Finite set of square **tiles**, each side has a **glue** and **strength**
- **Tile assembly system:** [tile set, seed tile, temperature (0,1,2,3,...)]
- Growth begins from the **seed** tile/assembly
- A tile **sticks** to an assembly if enough of its glues match so that the sum of the strengths of the matching glues is at least the **temperature**

Abstract tile assembly model

Tile assembly system:
tile set, seed tile, temperature

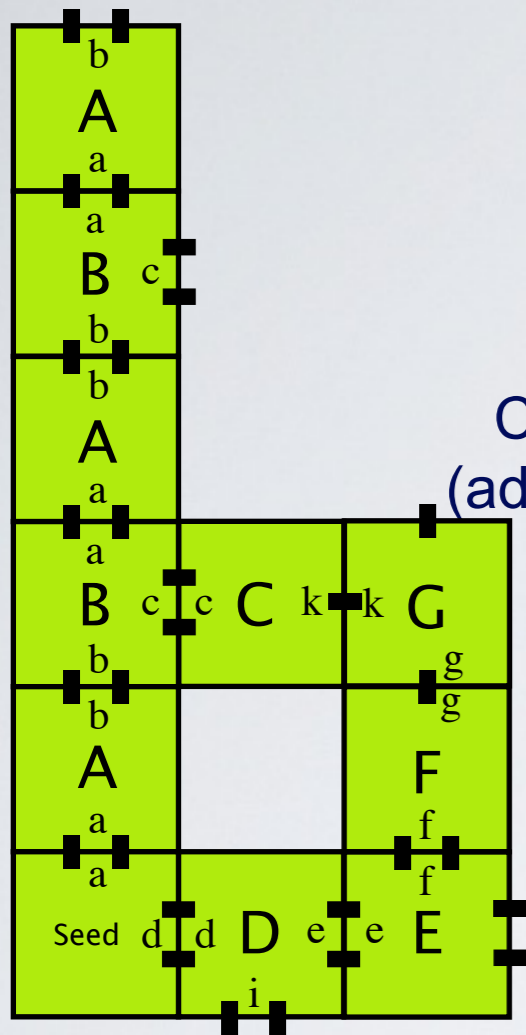

Cooperation
(adjacent sides)

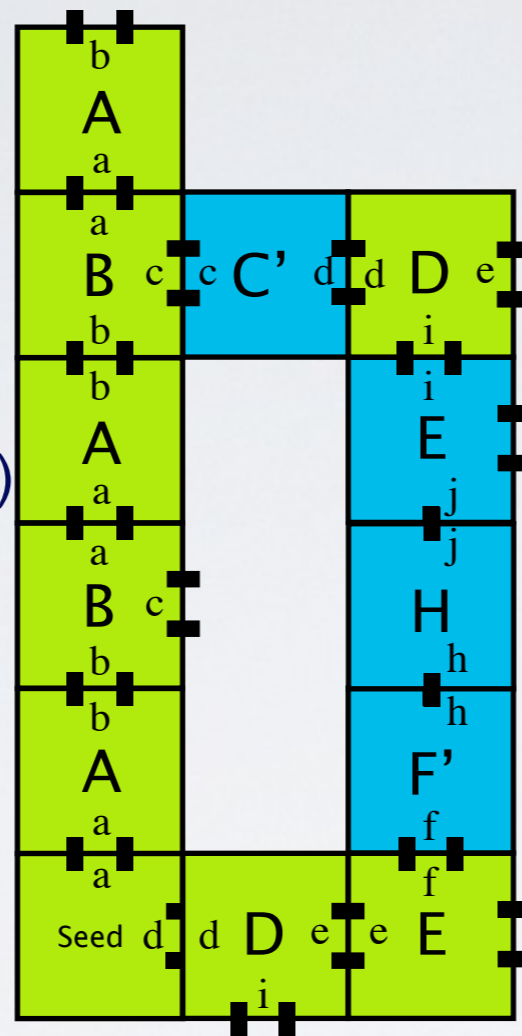

Cooperation
(opposite sides)

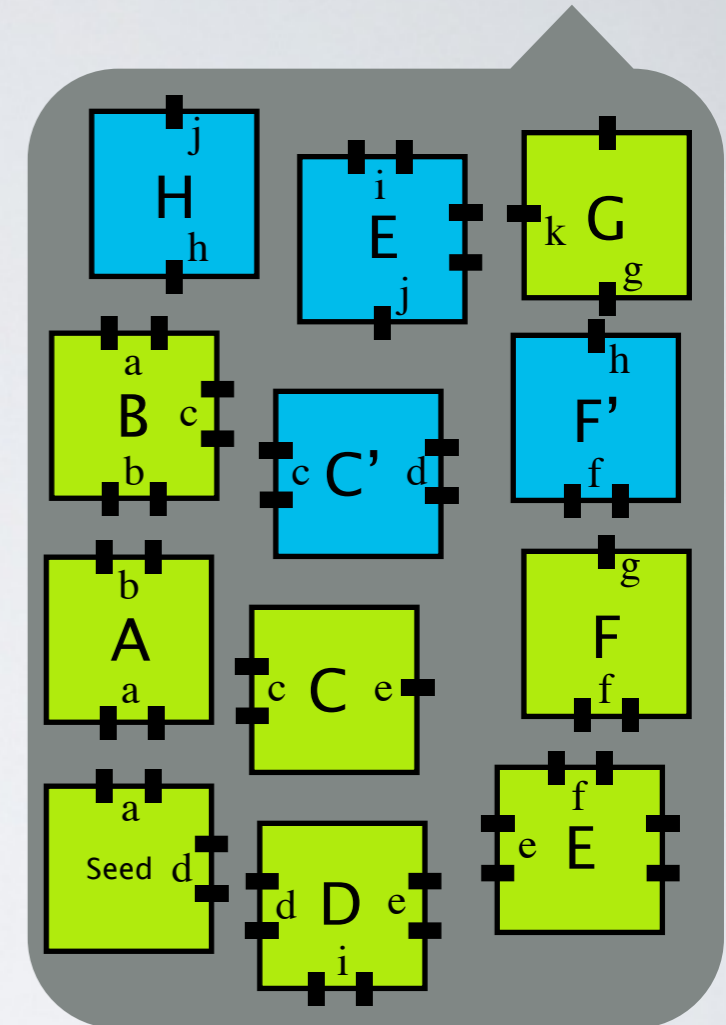

Temperature = 2

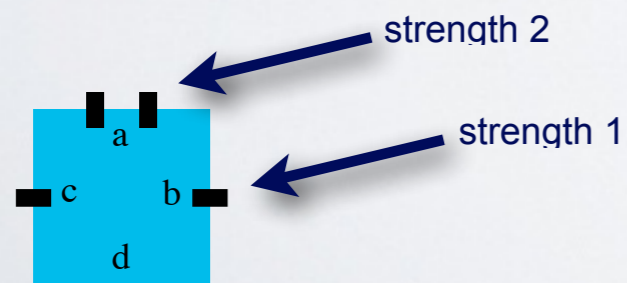

- Finite set of square **tiles**, each side has a **glue** and **strength**
- **Tile assembly system**: [tile set, seed tile, temperature (0,1,2,3,...)]
- Growth begins from the **seed** tile/assembly
- A tile **sticks** to an assembly if enough of its glues match so that the sum of the strengths of the matching glues is at least the **temperature**

Abstract tile assembly model

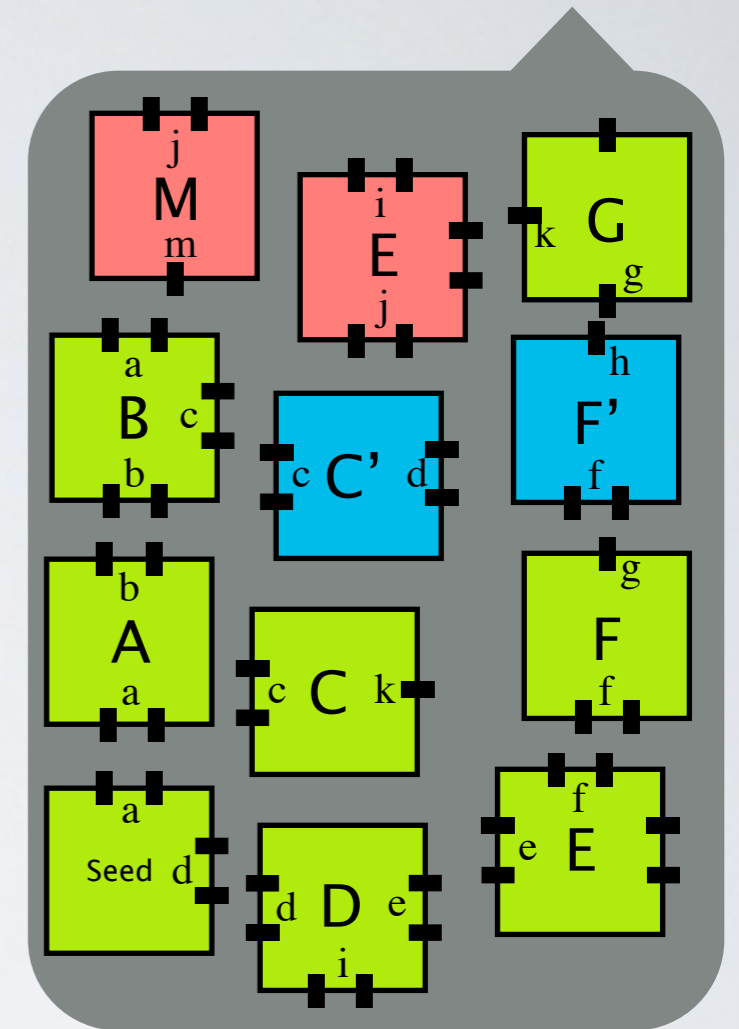
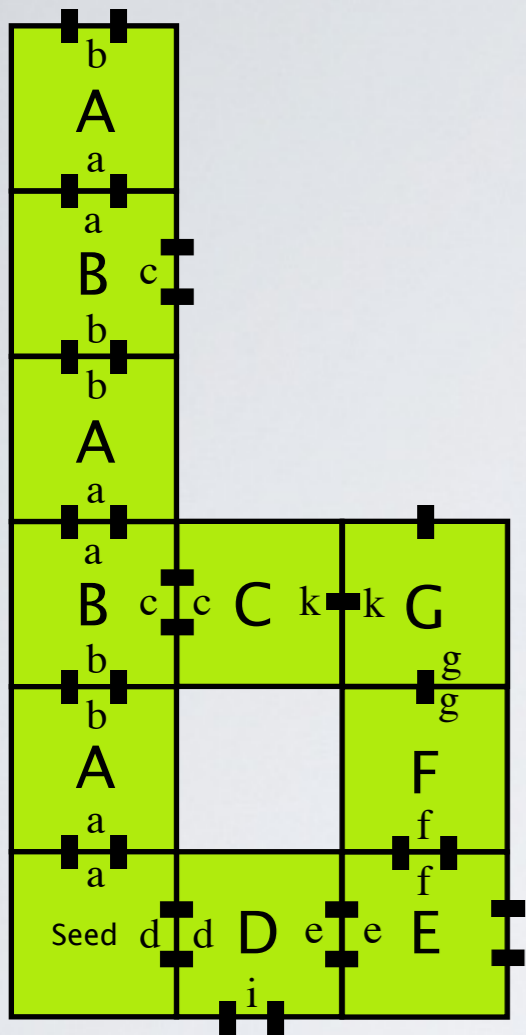

Temperature = 2

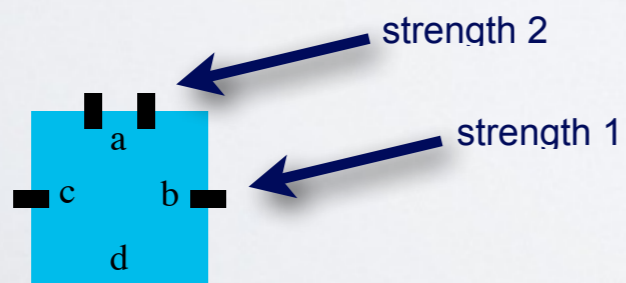

- Finite set of square **tiles**, each side has a **glue** and **strength**
- **Tile assembly system**: [tile set, seed tile, temperature (0,1,2,3,...)]
- Growth begins from the **seed** tile/assembly
- A tile **sticks** to an assembly if enough of its glues match so that the sum of the strengths of the matching glues is at least the **temperature**

Abstract tile assembly model

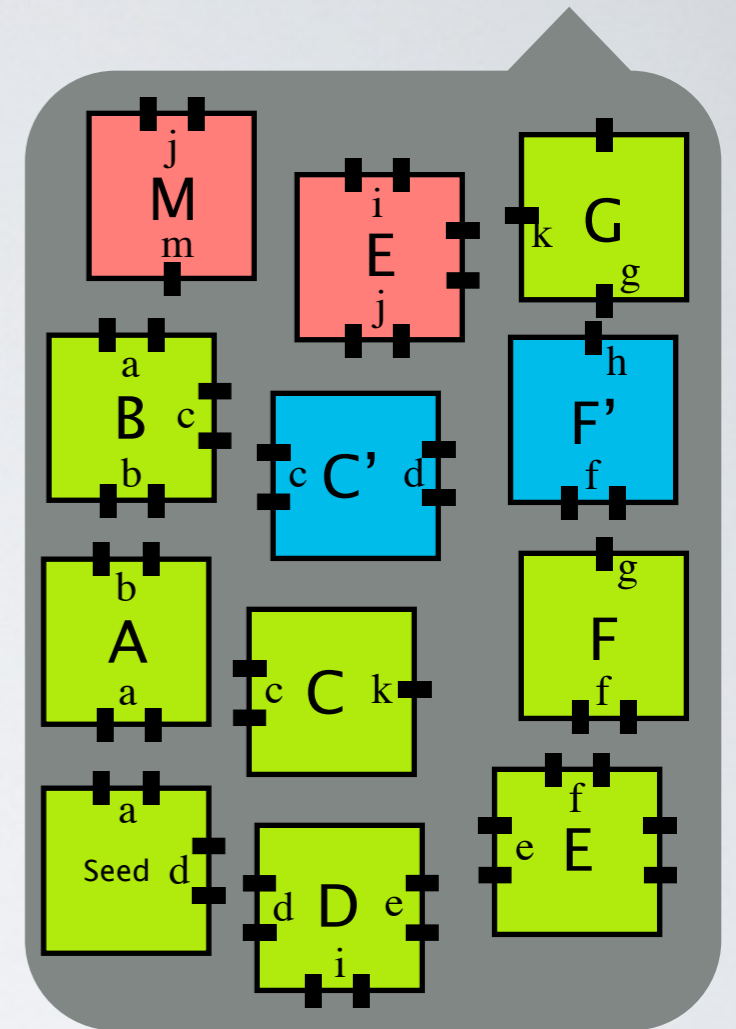
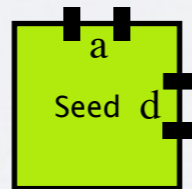
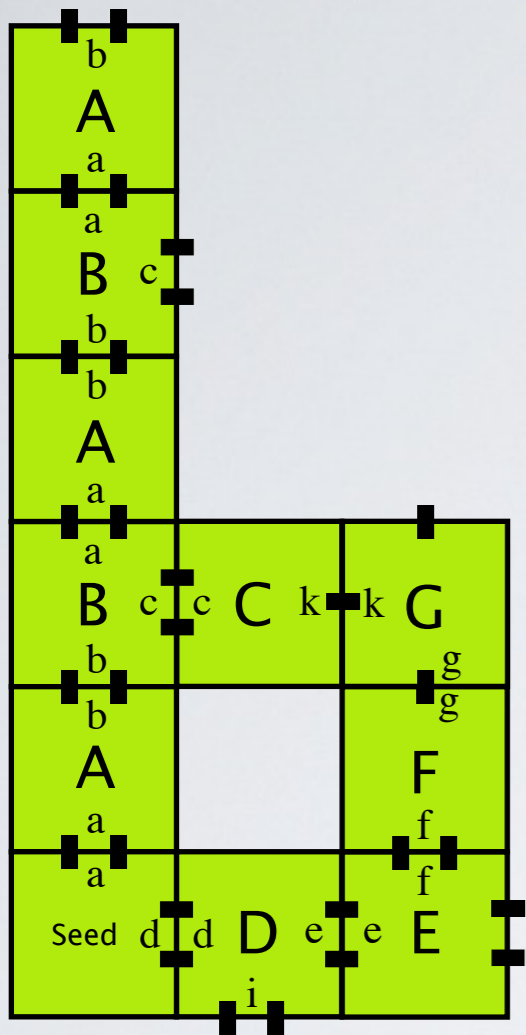

Temperature = 2

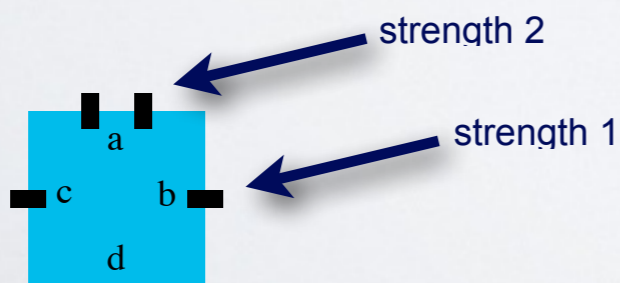

- Finite set of square **tiles**, each side has a **glue** and **strength**
- **Tile assembly system**: [tile set, seed tile, temperature (0,1,2,3,...)]
- Growth begins from the **seed** tile/assembly
- A tile **sticks** to an assembly if enough of its glues match so that the sum of the strengths of the matching glues is at least the **temperature**

Abstract tile assembly model

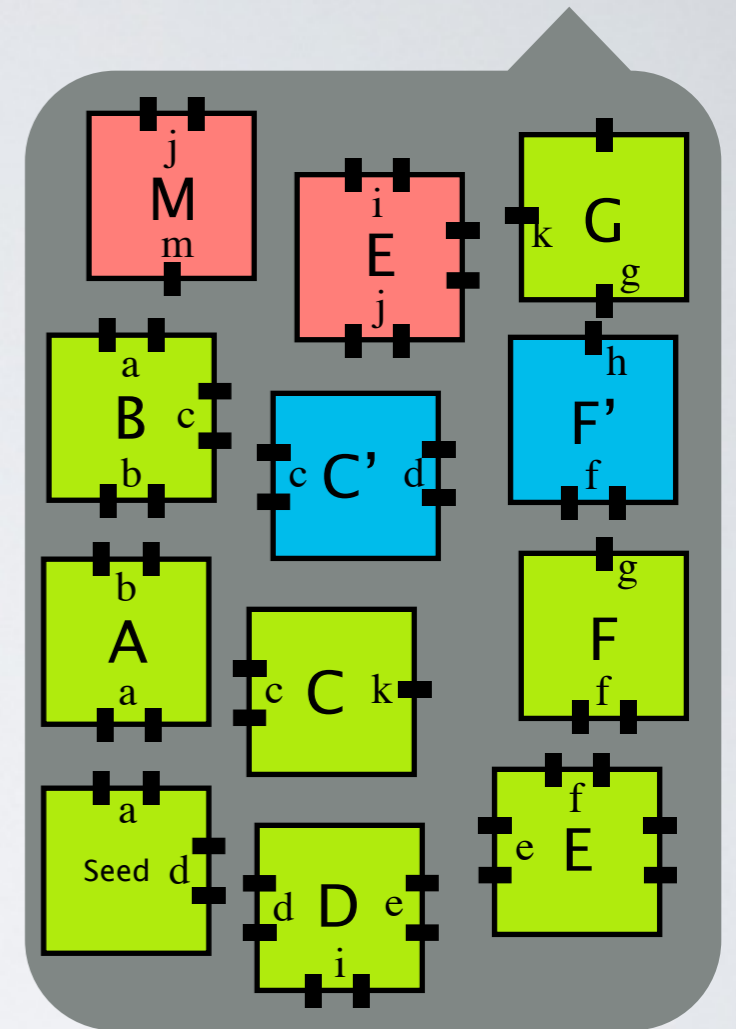
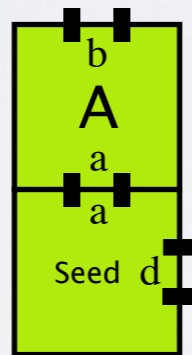
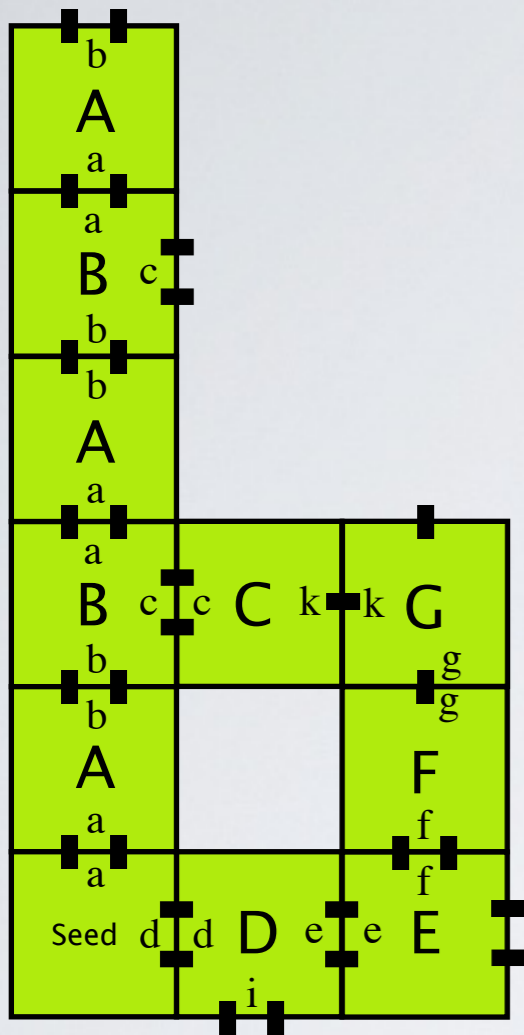

Temperature = 2

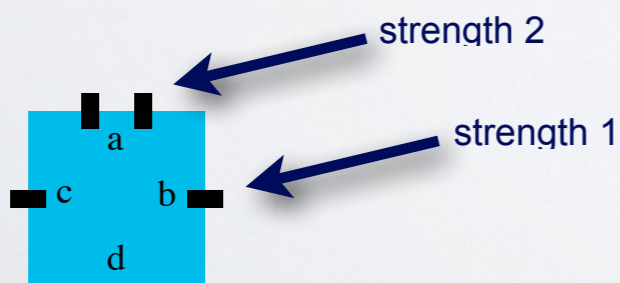

- Finite set of square **tiles**, each side has a **glue** and **strength**
- **Tile assembly system**: [tile set, seed tile, temperature (0,1,2,3,...)]
- Growth begins from the **seed** tile/assembly
- A tile **sticks** to an assembly if enough of its glues match so that the sum of the strengths of the matching glues is at least the **temperature**

Abstract tile assembly model

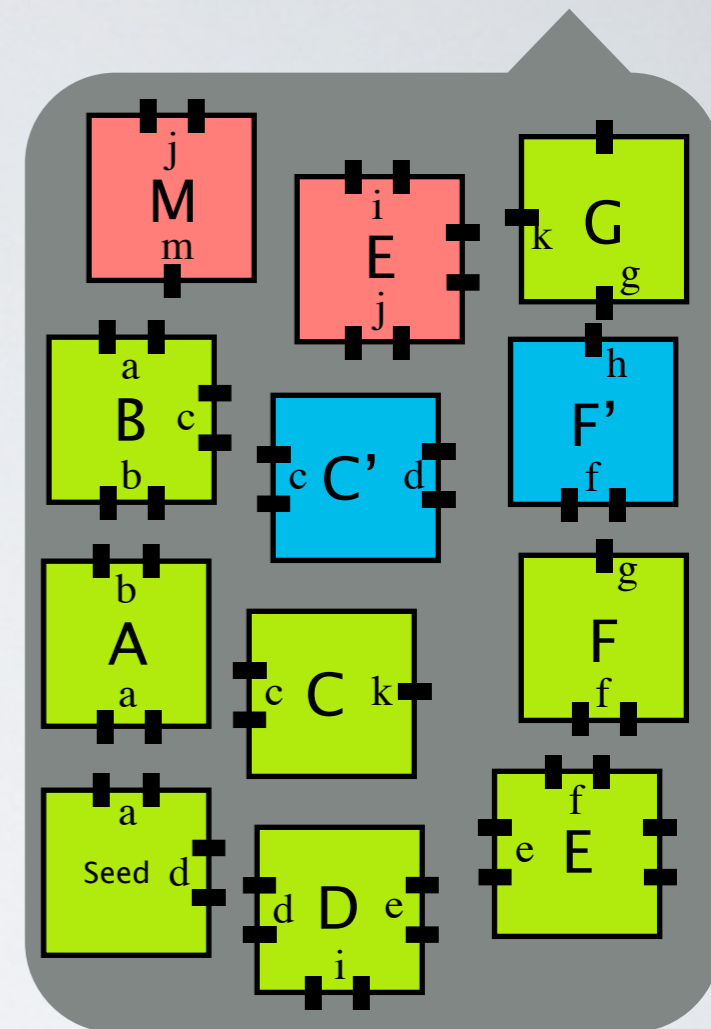
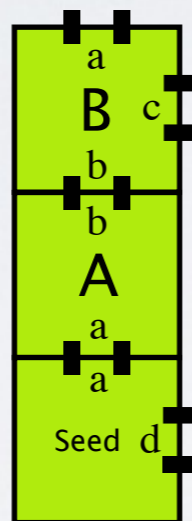
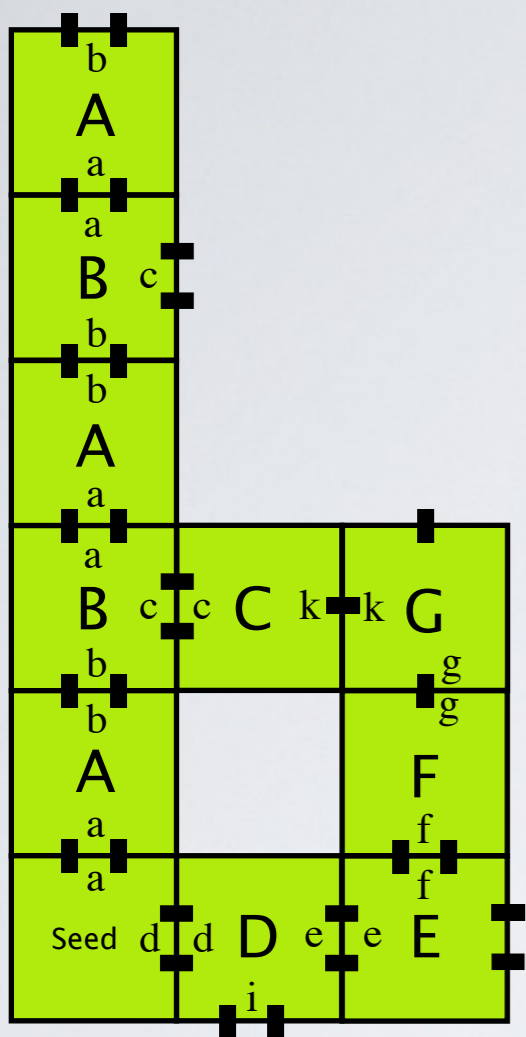

Temperature = 2

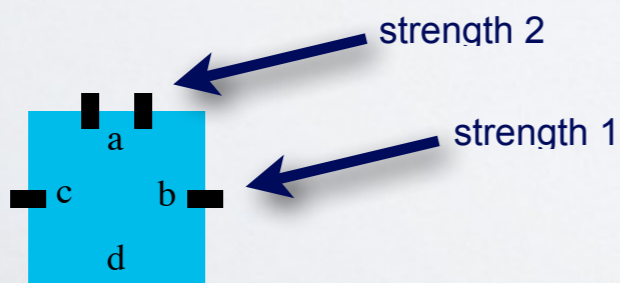

- Finite set of square **tiles**, each side has a **glue** and **strength**
- **Tile assembly system:** [tile set, seed tile, temperature (0,1,2,3,...)]
- Growth begins from the **seed** tile/assembly
- A tile **sticks** to an assembly if enough of its glues match so that the sum of the strengths of the matching glues is at least the **temperature**

Abstract tile assembly model

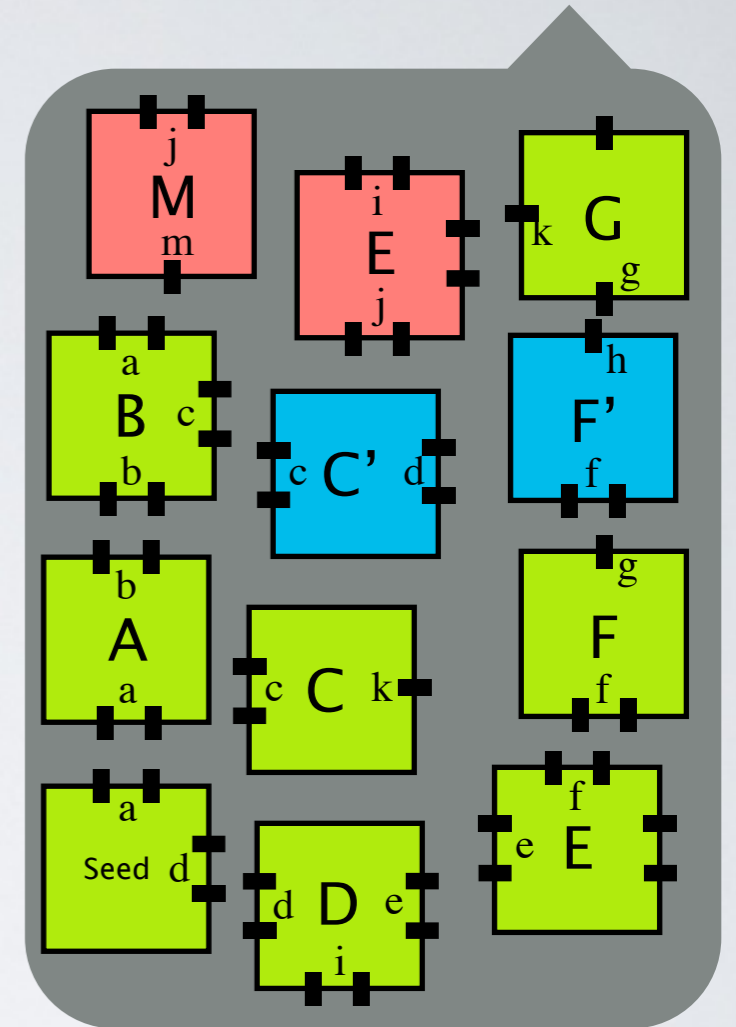
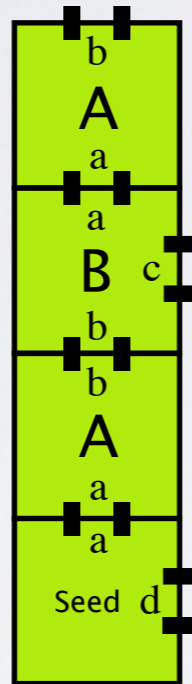
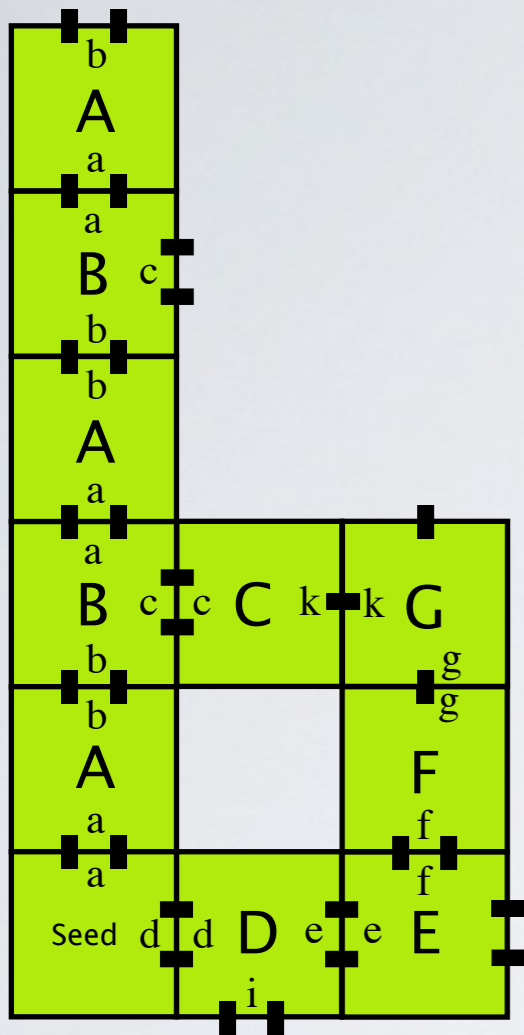

Temperature = 2

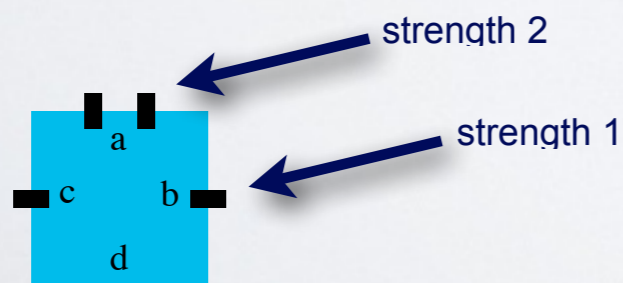

- Finite set of square **tiles**, each side has a **glue** and **strength**
- **Tile assembly system**: [tile set, seed tile, temperature (0,1,2,3,...)]
- Growth begins from the **seed** tile/assembly
- A tile **sticks** to an assembly if enough of its glues match so that the sum of the strengths of the matching glues is at least the **temperature**

Abstract tile assembly model

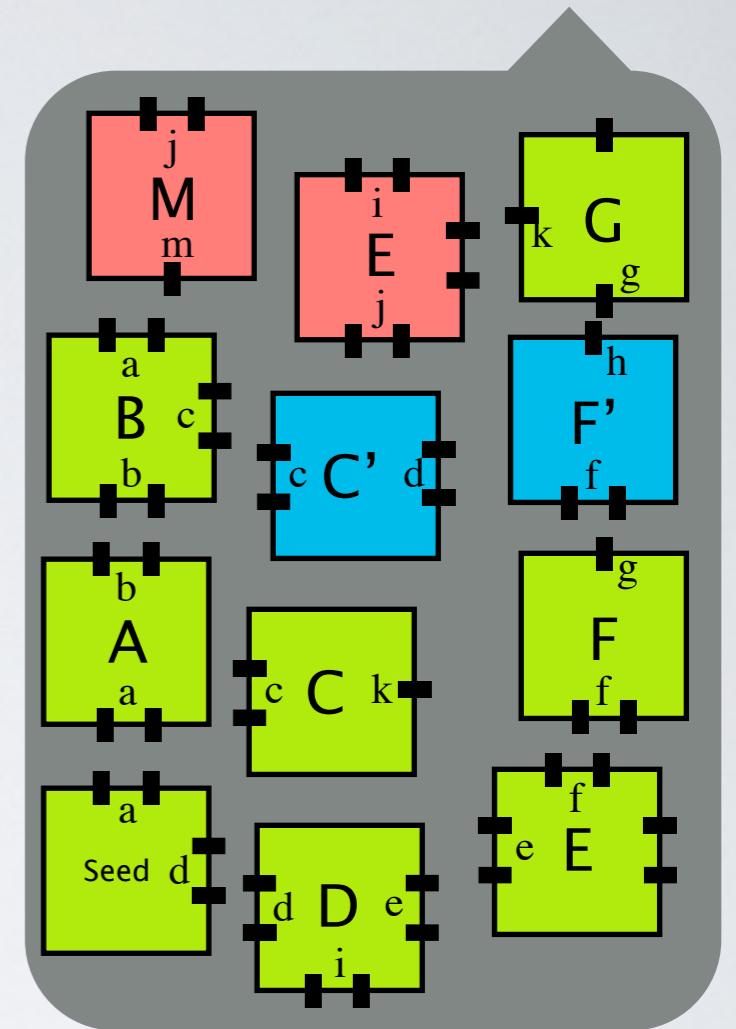
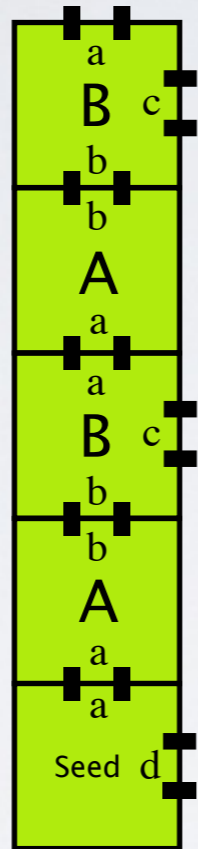
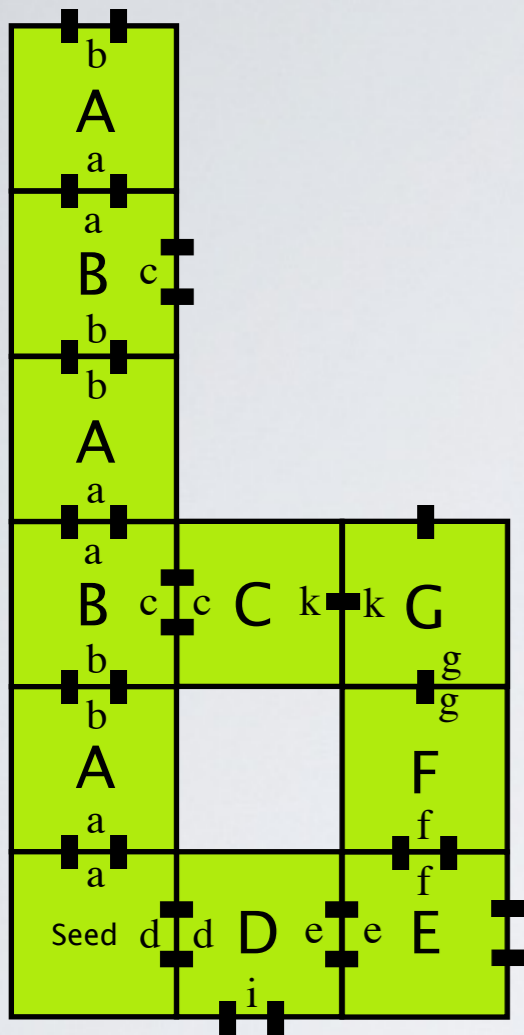

Temperature = 2

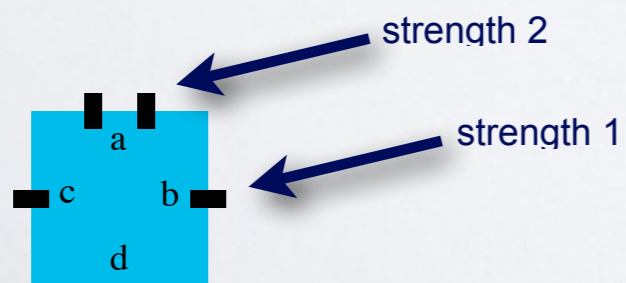

- Finite set of square **tiles**, each side has a **glue** and **strength**
- **Tile assembly system**: [tile set, seed tile, temperature (0,1,2,3,...)]
- Growth begins from the **seed** tile/assembly
- A tile **sticks** to an assembly if enough of its glues match so that the sum of the strengths of the matching glues is at least the **temperature**

Abstract tile assembly model

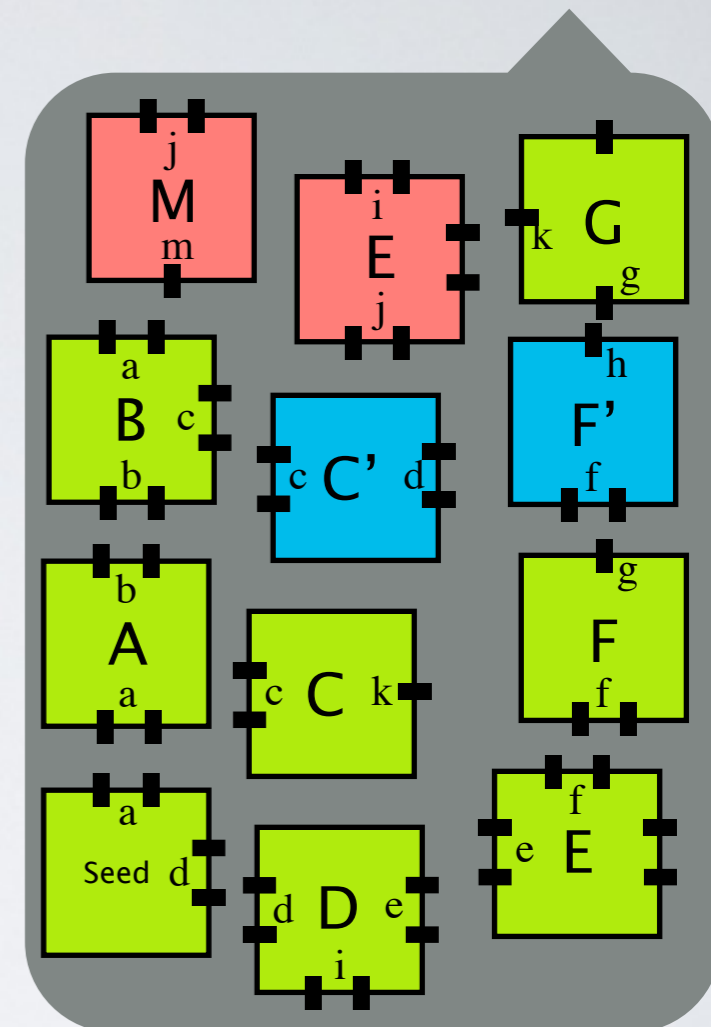
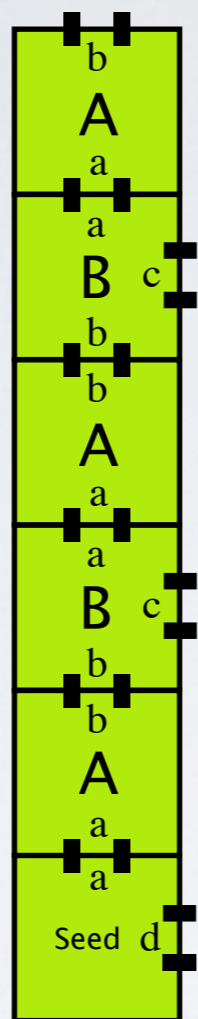
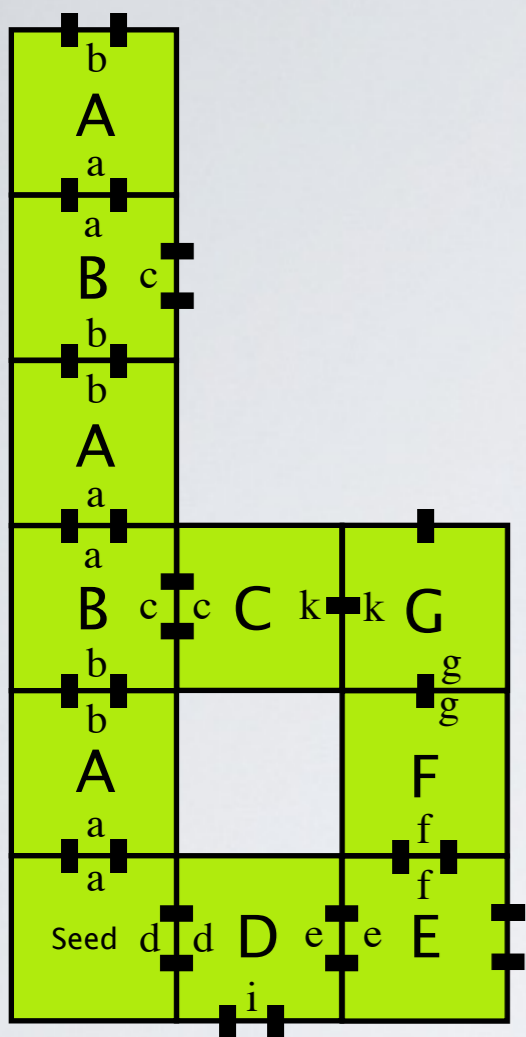

Temperature = 2

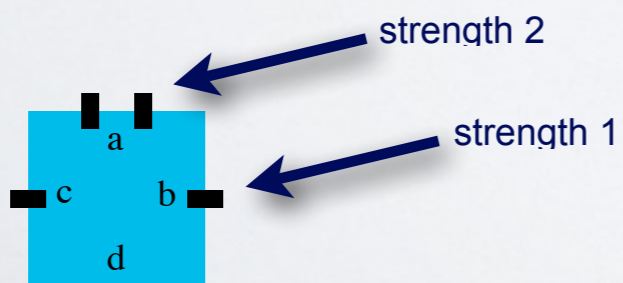

- Finite set of square **tiles**, each side has a **glue** and **strength**
- **Tile assembly system**: [tile set, seed tile, temperature (0,1,2,3,...)]
- Growth begins from the **seed** tile/assembly
- A tile **sticks** to an assembly if enough of its glues match so that the sum of the strengths of the matching glues is at least the **temperature**

Abstract tile assembly model

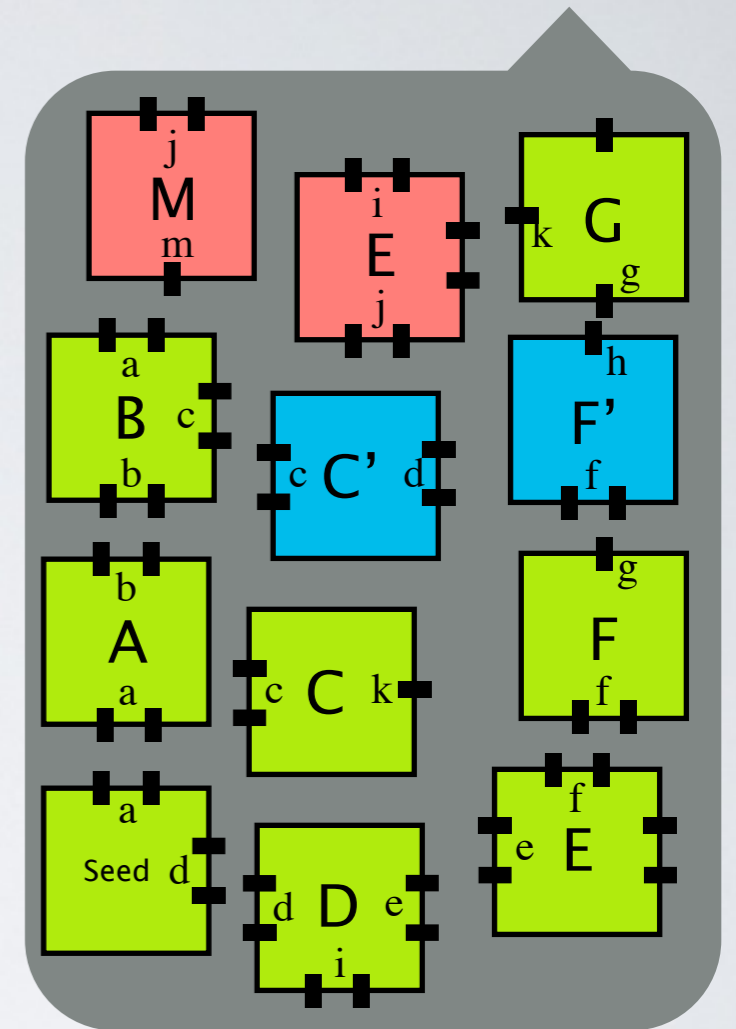
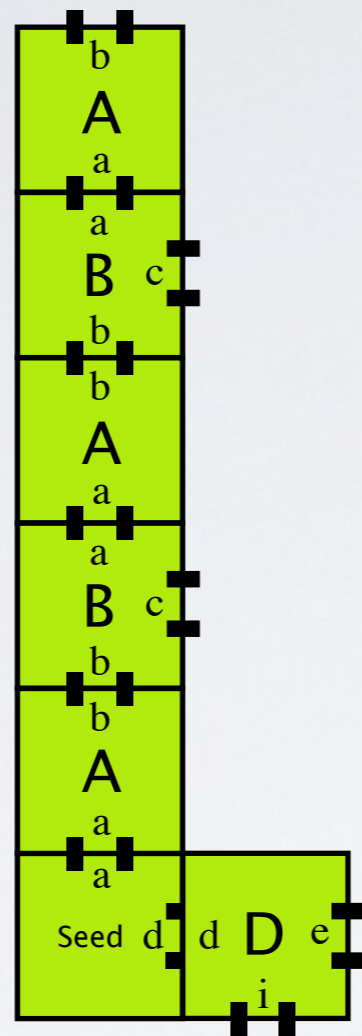
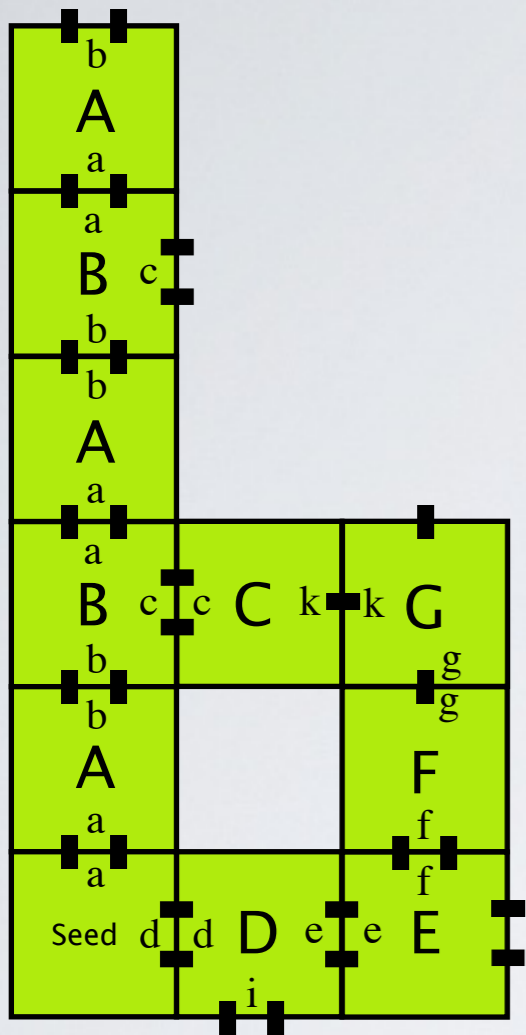

Temperature = 2

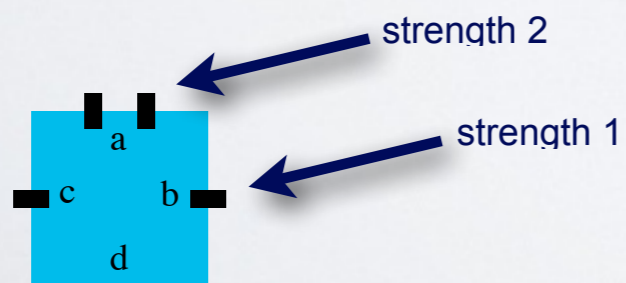

- Finite set of square **tiles**, each side has a **glue** and **strength**
- **Tile assembly system**: [tile set, seed tile, temperature (0,1,2,3,...)]
- Growth begins from the **seed** tile/assembly
- A tile **sticks** to an assembly if enough of its glues match so that the sum of the strengths of the matching glues is at least the **temperature**

Abstract tile assembly model

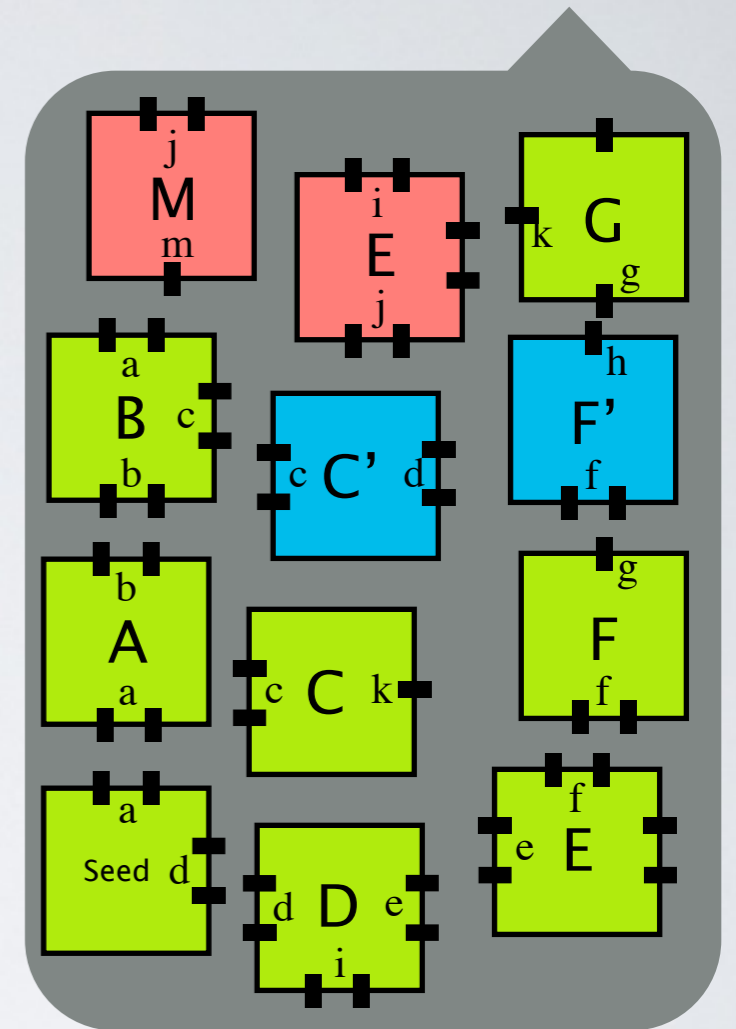
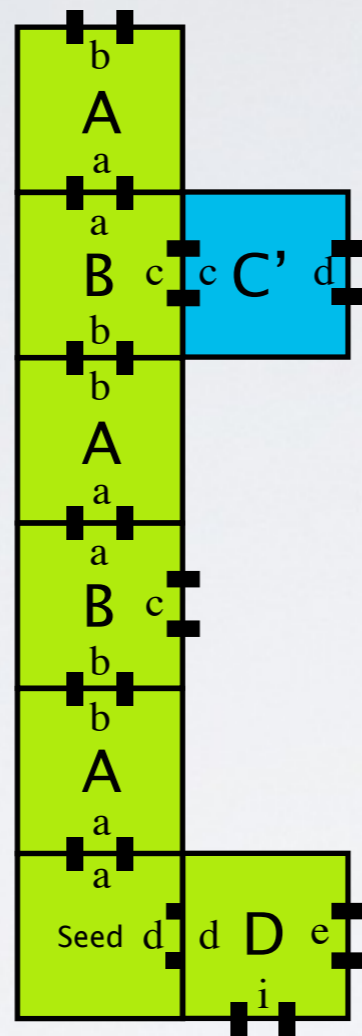
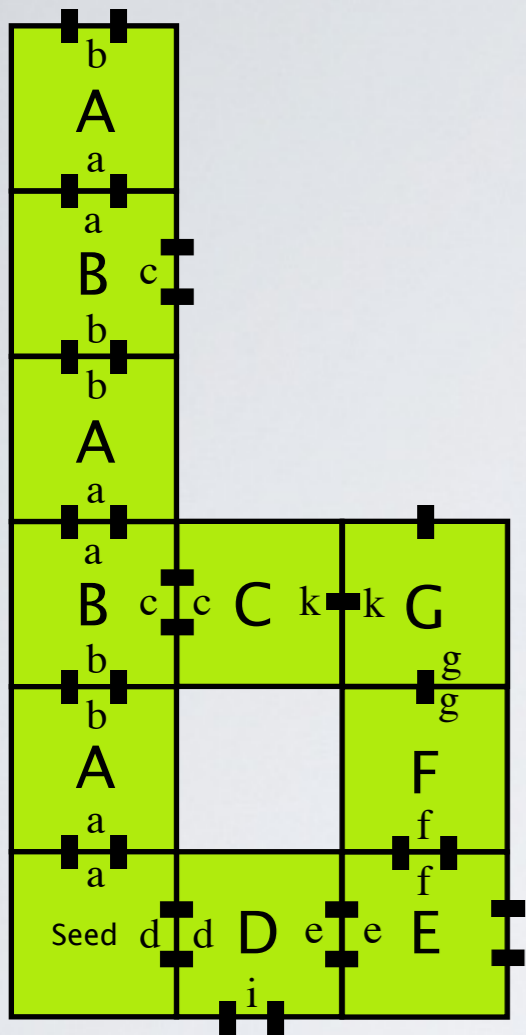

Temperature = 2

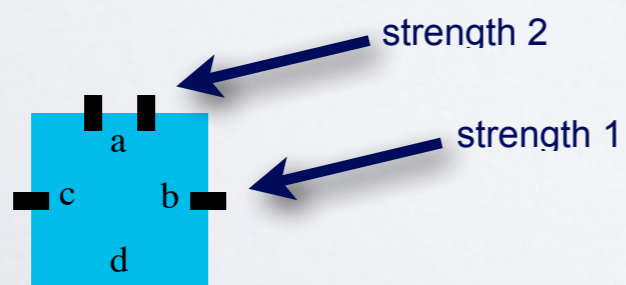

- Finite set of square **tiles**, each side has a **glue** and **strength**
- **Tile assembly system**: [tile set, seed tile, temperature (0,1,2,3,...)]
- Growth begins from the **seed** tile/assembly
- A tile **sticks** to an assembly if enough of its glues match so that the sum of the strengths of the matching glues is at least the **temperature**

Abstract tile assembly model

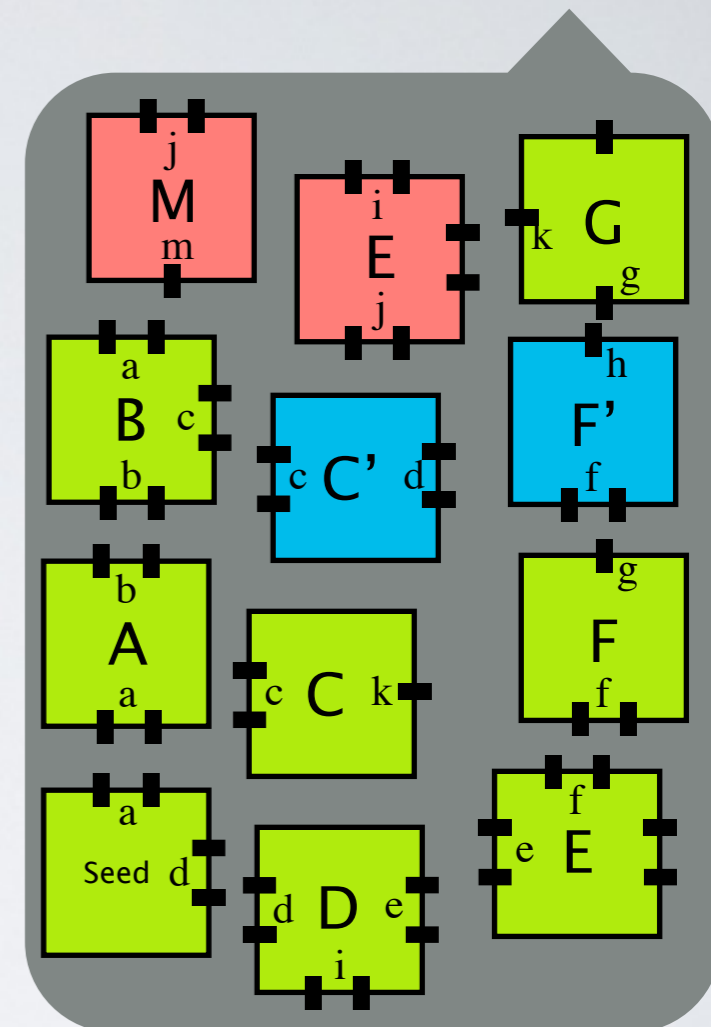
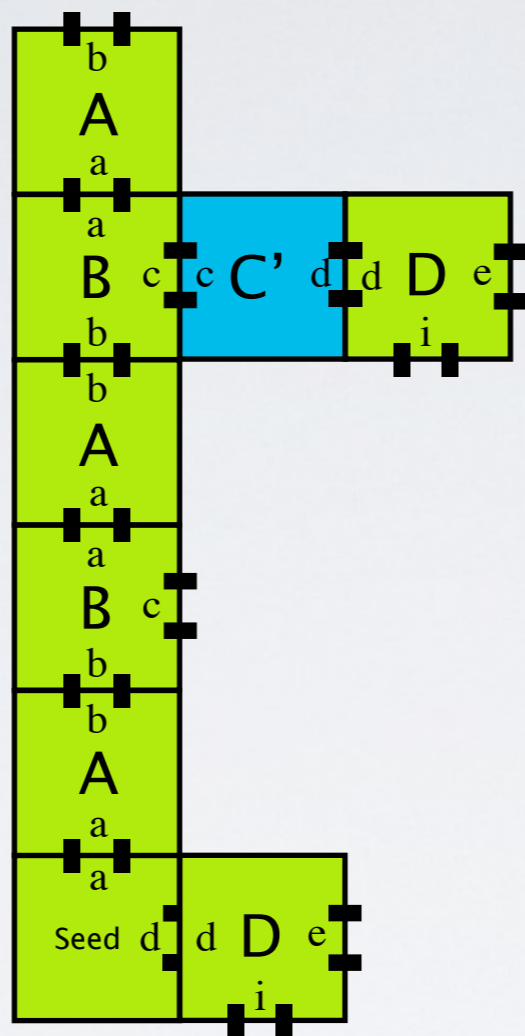
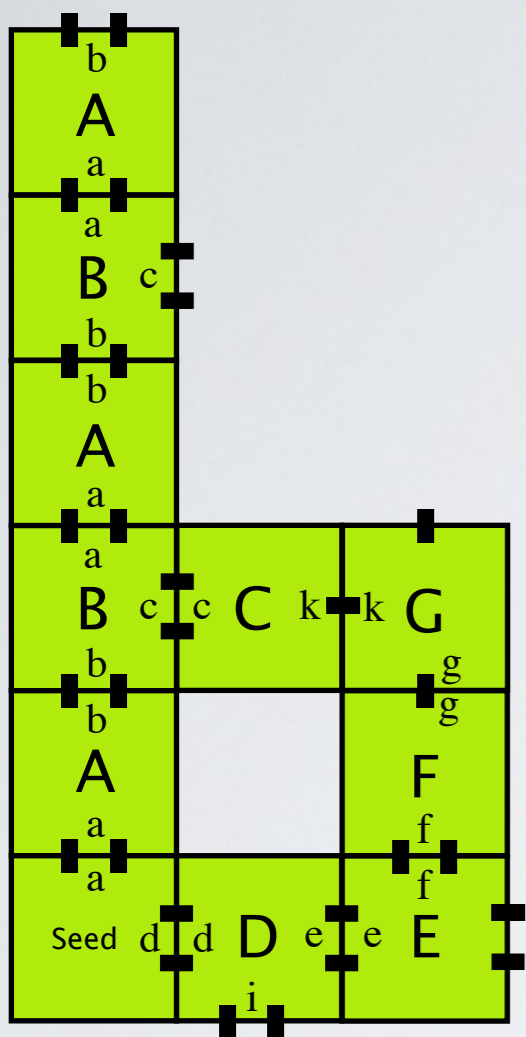

Temperature = 2

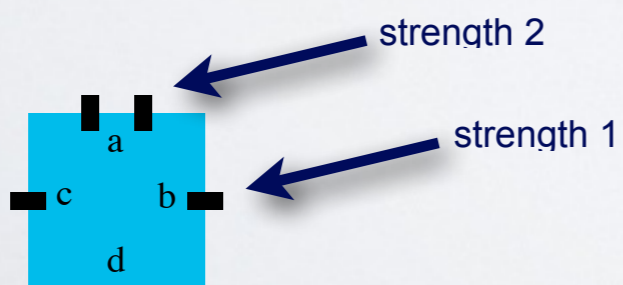

- Finite set of square **tiles**, each side has a **glue** and **strength**
- **Tile assembly system:** [tile set, seed tile, temperature (0,1,2,3,...)]
- Growth begins from the **seed** tile/assembly
- A tile **sticks** to an assembly if enough of its glues match so that the sum of the strengths of the matching glues is at least the **temperature**

Abstract tile assembly model

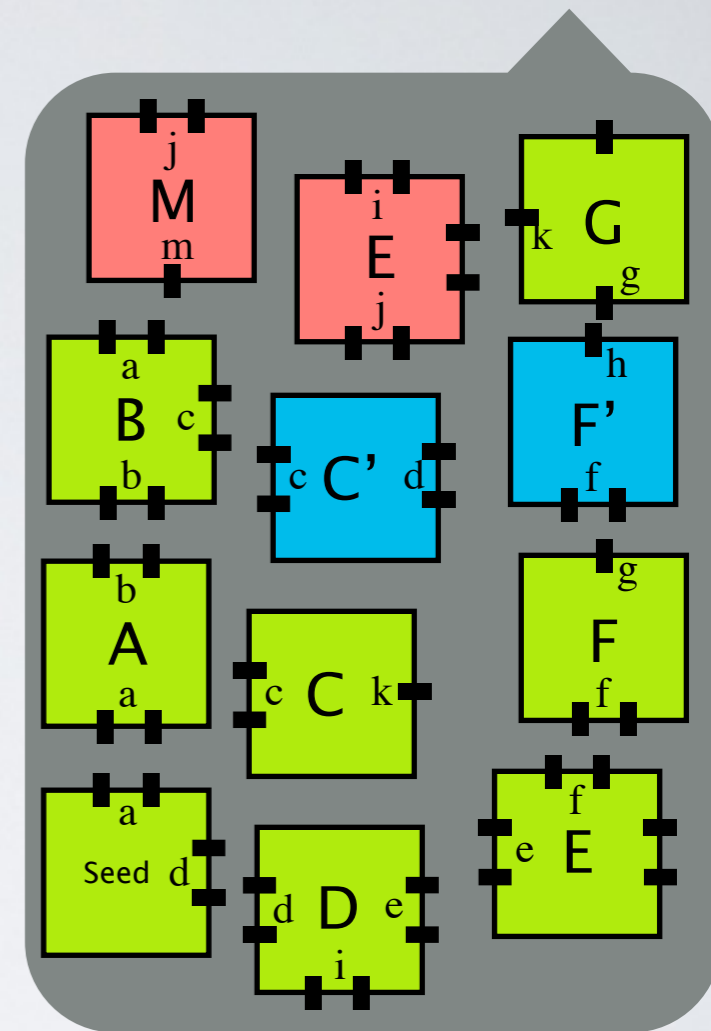
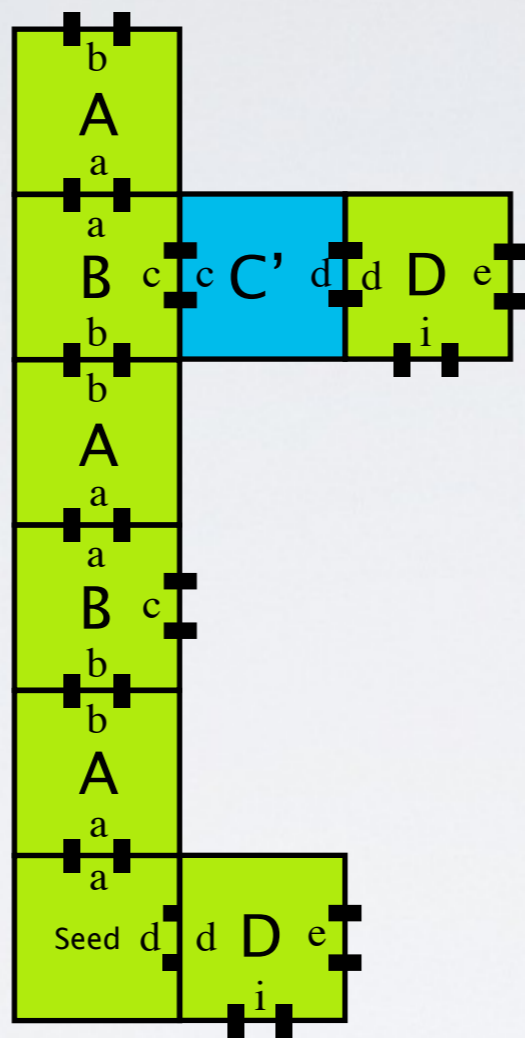
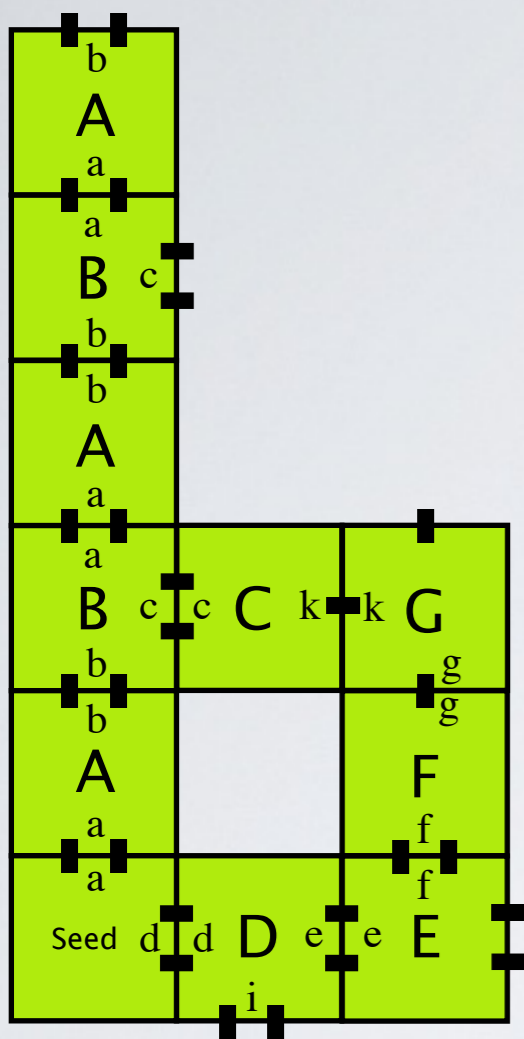

Temperature = 2

Order of tile placement is nondeterministic
(asynchronous growth).

More than one tile type can go at a given position

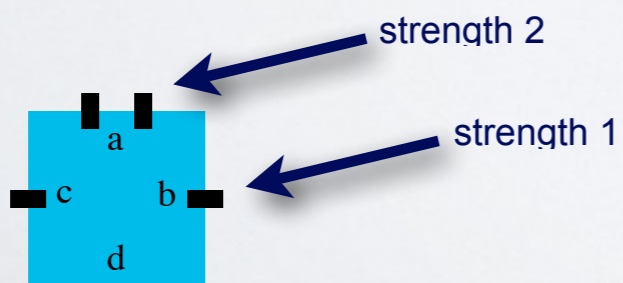

- Finite set of square **tiles**, each side has a **glue** and **strength**
- **Tile assembly system:** [tile set, seed tile, temperature (0,1,2,3,...)]
- Growth begins from the **seed** tile/assembly
- A tile **sticks** to an assembly if enough of its glues match so that the sum of the strengths of the matching glues is at least the **temperature**

Abstract tile assembly model

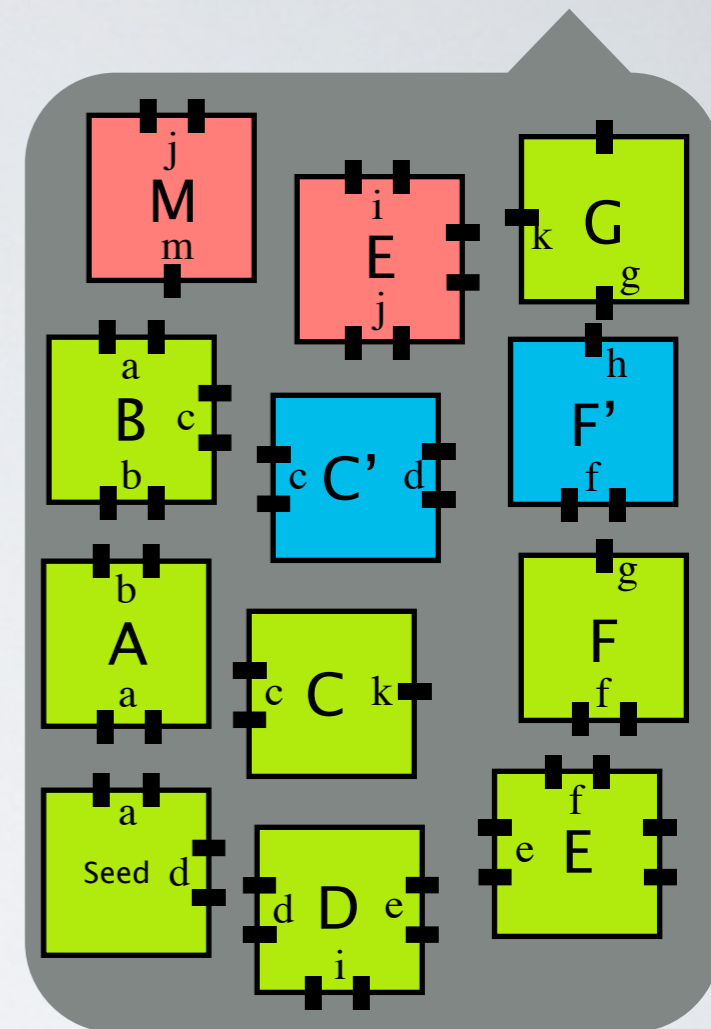
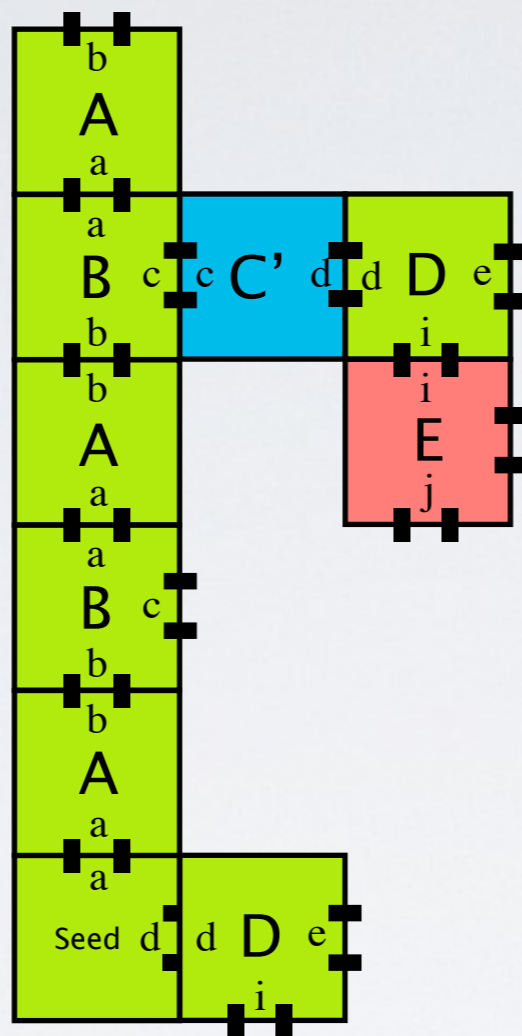
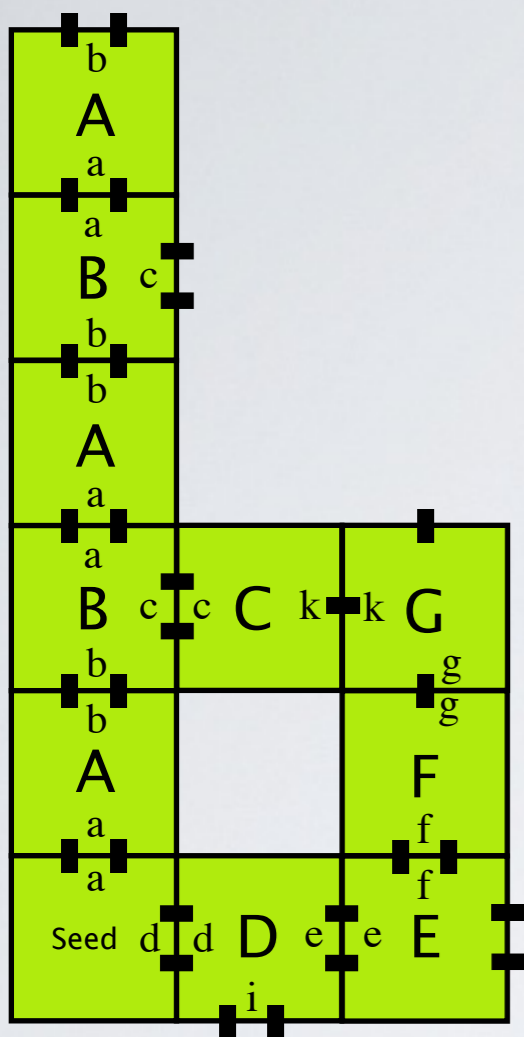

Temperature = 2

Order of tile placement is nondeterministic
(asynchronous growth).

More than one tile type can go at a given position

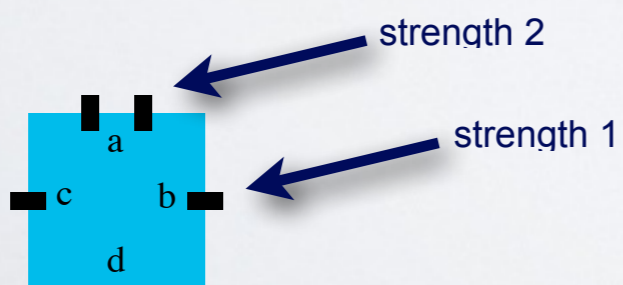

- Finite set of square **tiles**, each side has a **glue** and **strength**
- **Tile assembly system**: [tile set, seed tile, temperature (0,1,2,3,...)]
- Growth begins from the **seed** tile/assembly
- A tile **sticks** to an assembly if enough of its glues match so that the sum of the strengths of the matching glues is at least the **temperature**

Abstract tile assembly model

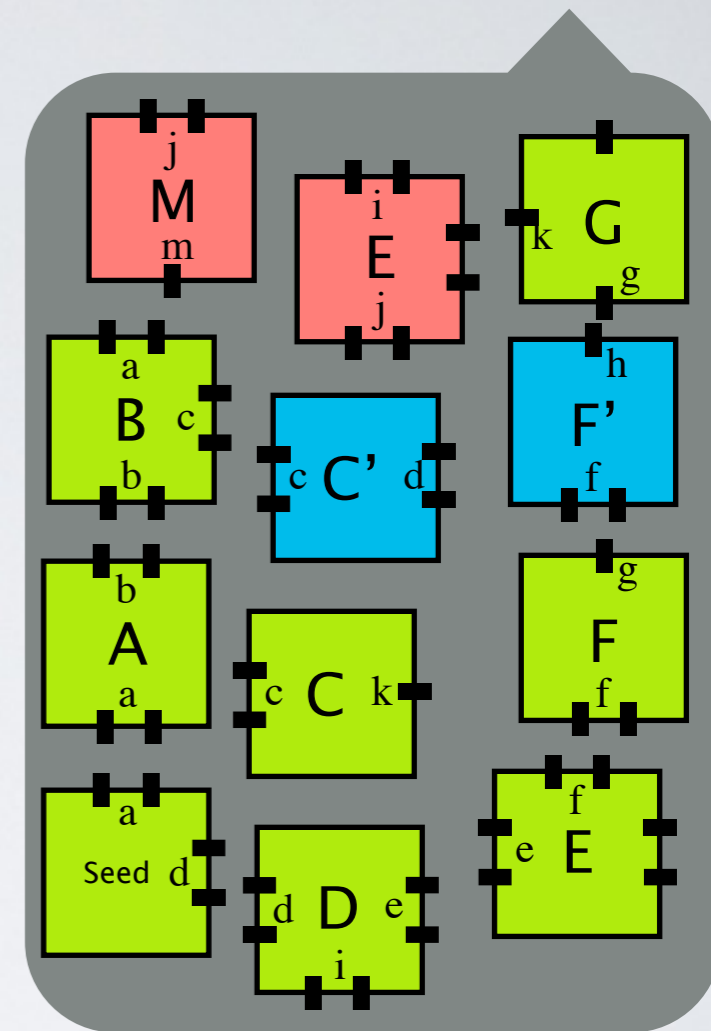
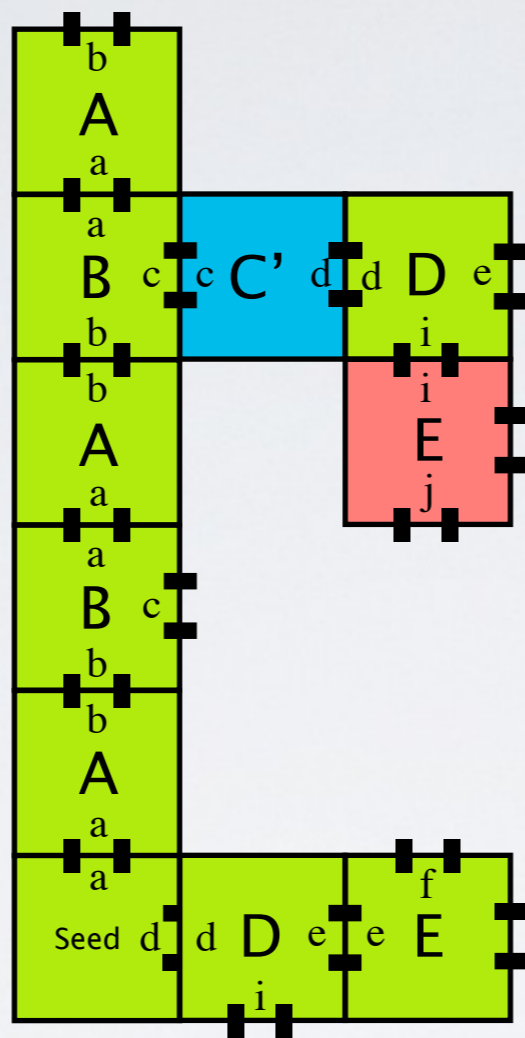
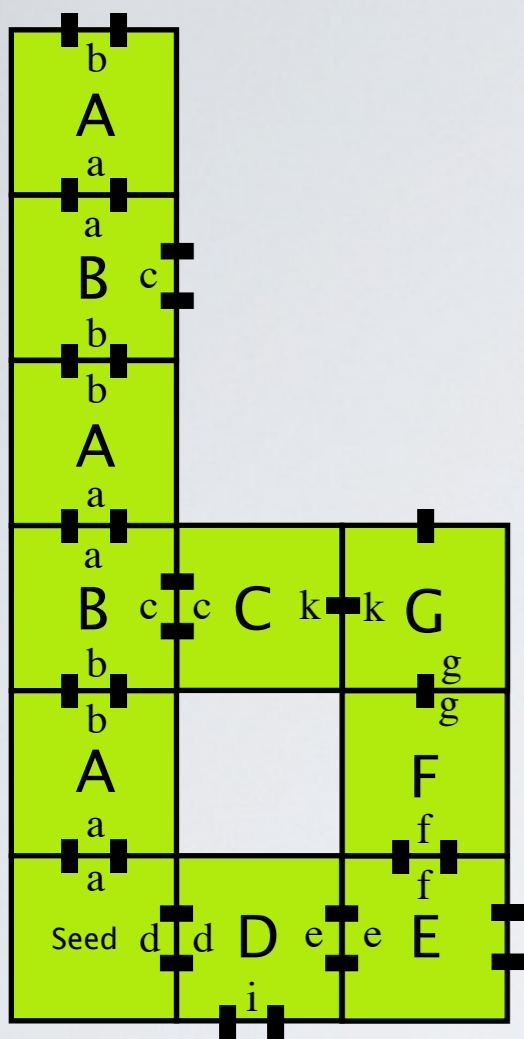

Temperature = 2

Order of tile placement is nondeterministic
(asynchronous growth).

More than one tile type can go at a given position

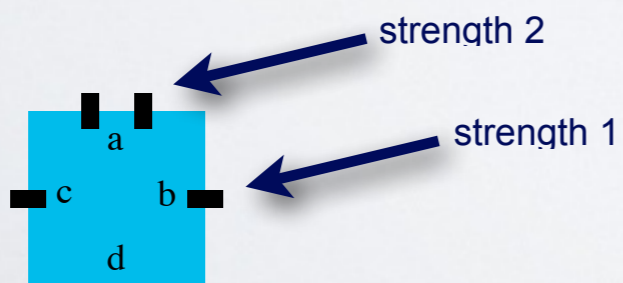

- Finite set of square **tiles**, each side has a **glue** and **strength**
- **Tile assembly system:** [tile set, seed tile, temperature (0,1,2,3,...)]
- Growth begins from the **seed** tile/assembly
- A tile **sticks** to an assembly if enough of its glues match so that the sum of the strengths of the matching glues is at least the **temperature**

Abstract tile assembly model

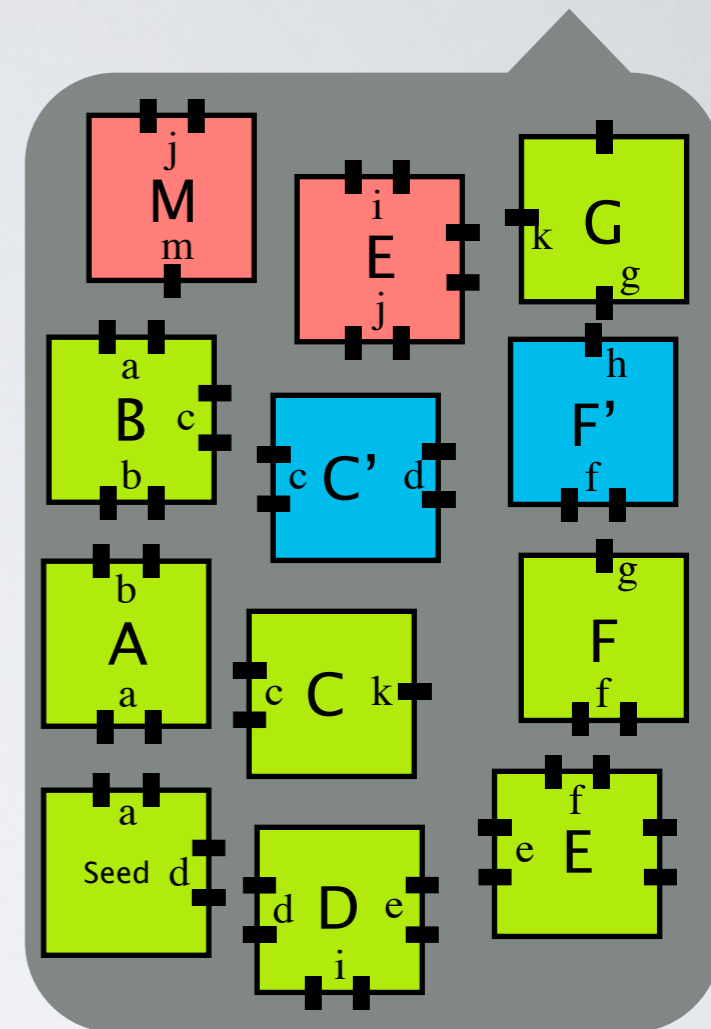
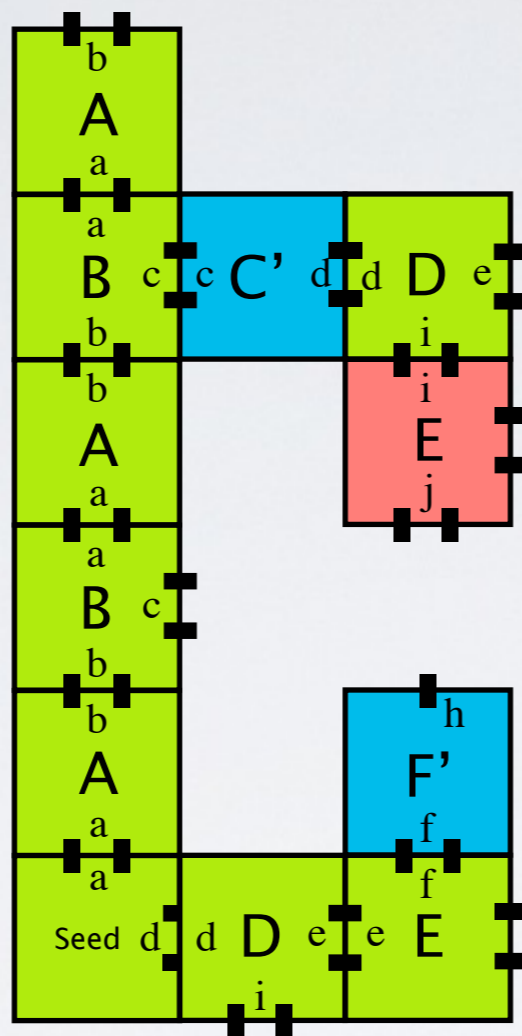
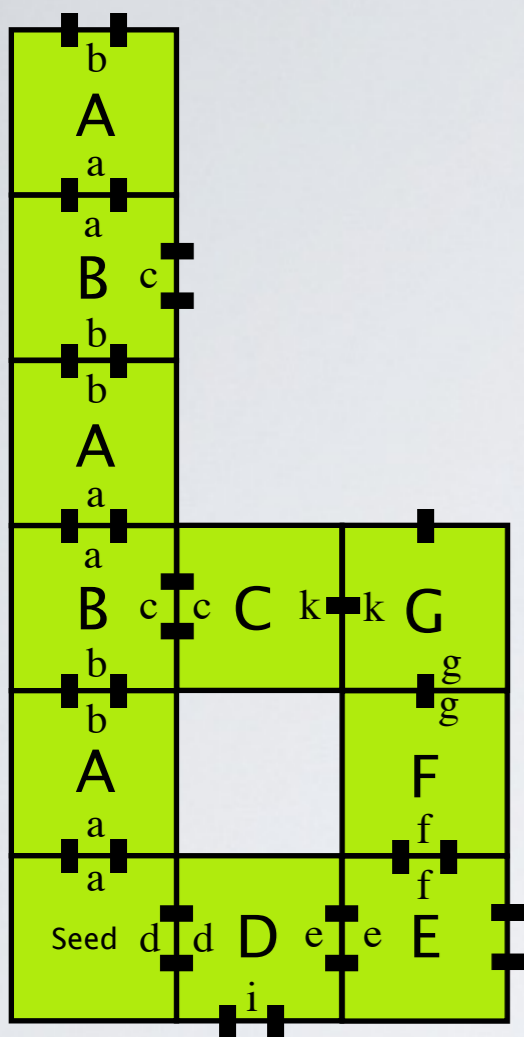

Temperature = 2

Order of tile placement is nondeterministic
(asynchronous growth).

More than one tile type can go at a given position

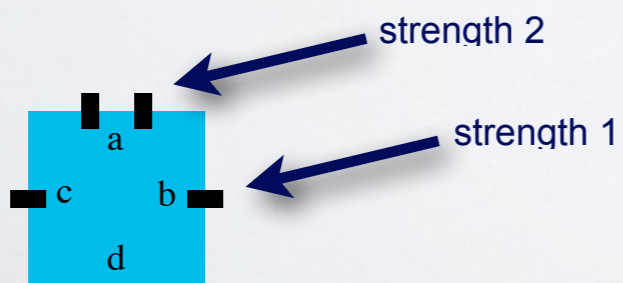

- Finite set of square **tiles**, each side has a **glue** and **strength**
- **Tile assembly system**: [tile set, seed tile, temperature (0,1,2,3,...)]
- Growth begins from the **seed** tile/assembly
- A tile **sticks** to an assembly if enough of its glues match so that the sum of the strengths of the matching glues is at least the **temperature**

Abstract tile assembly model

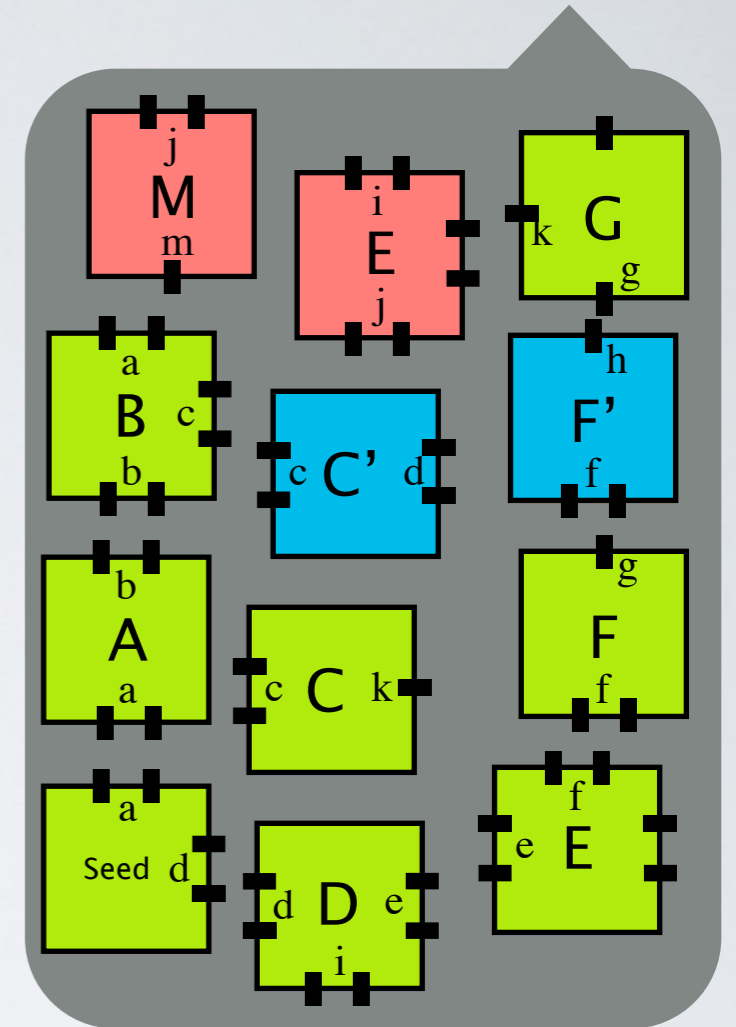
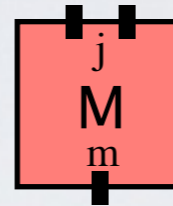
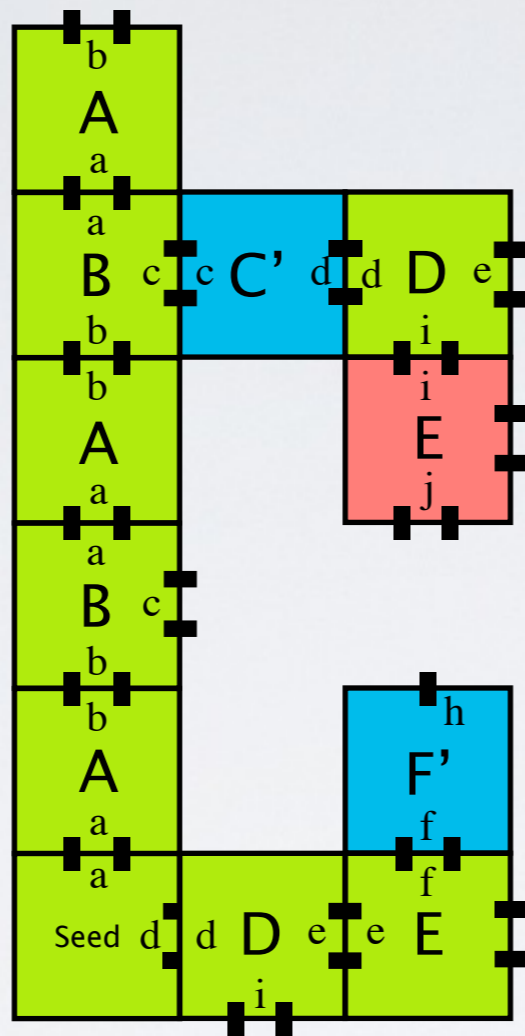
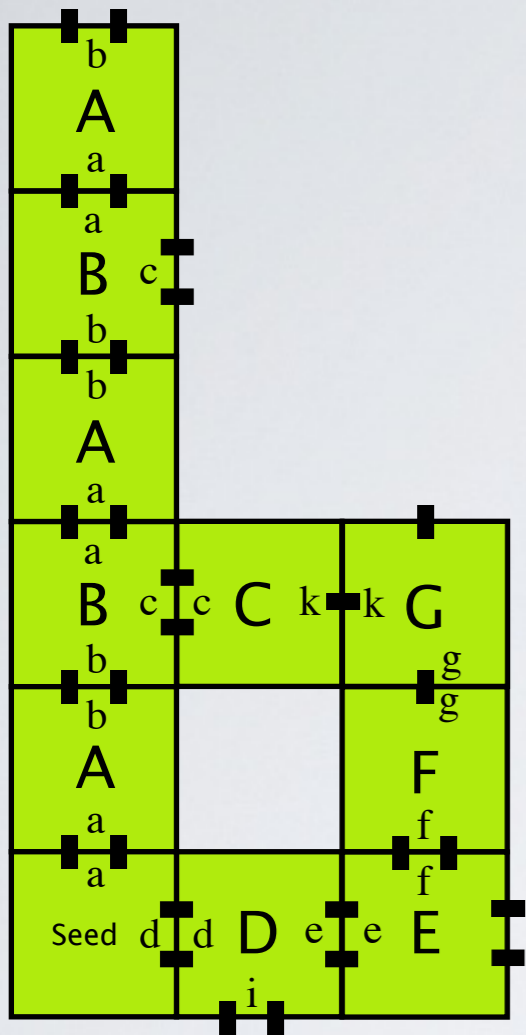

Temperature = 2

Order of tile placement is nondeterministic
(asynchronous growth).

More than one tile type can go at a given position

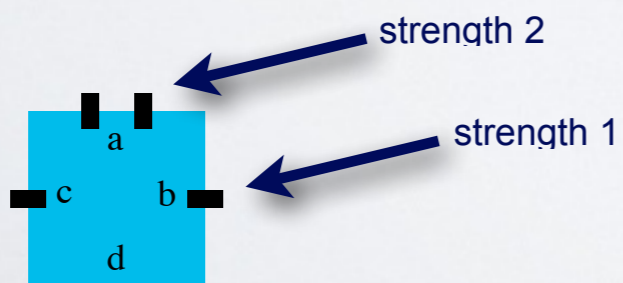

- Finite set of square **tiles**, each side has a **glue** and **strength**
- **Tile assembly system**: [tile set, seed tile, temperature (0,1,2,3,...)]
- Growth begins from the **seed** tile/assembly
- A tile **sticks** to an assembly if enough of its glues match so that the sum of the strengths of the matching glues is at least the **temperature**

Abstract tile assembly model

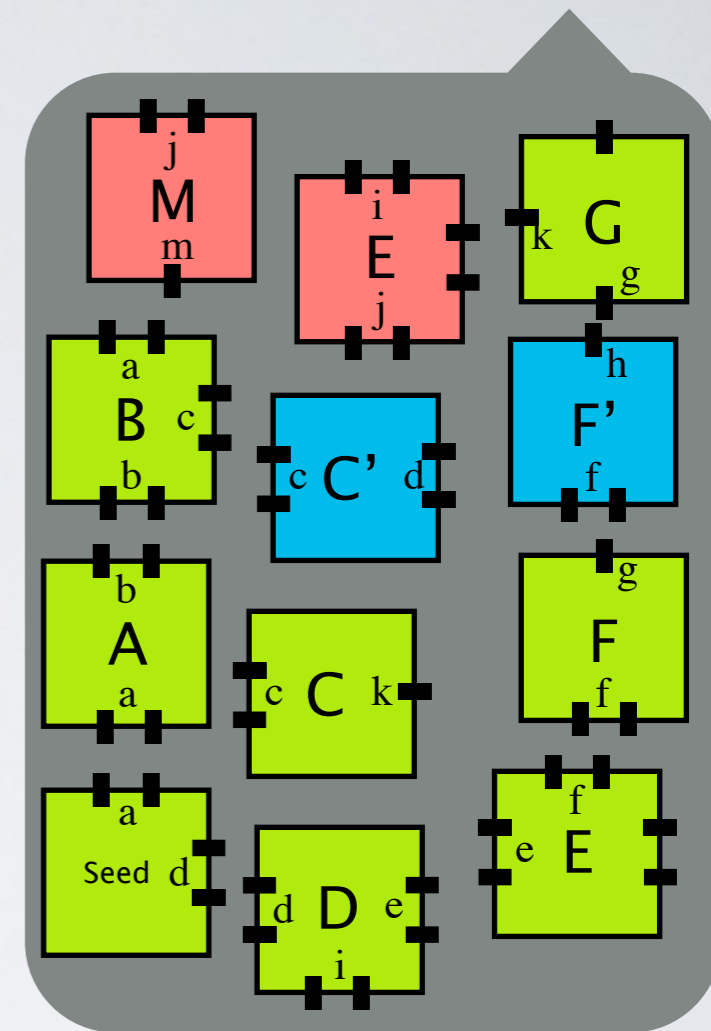
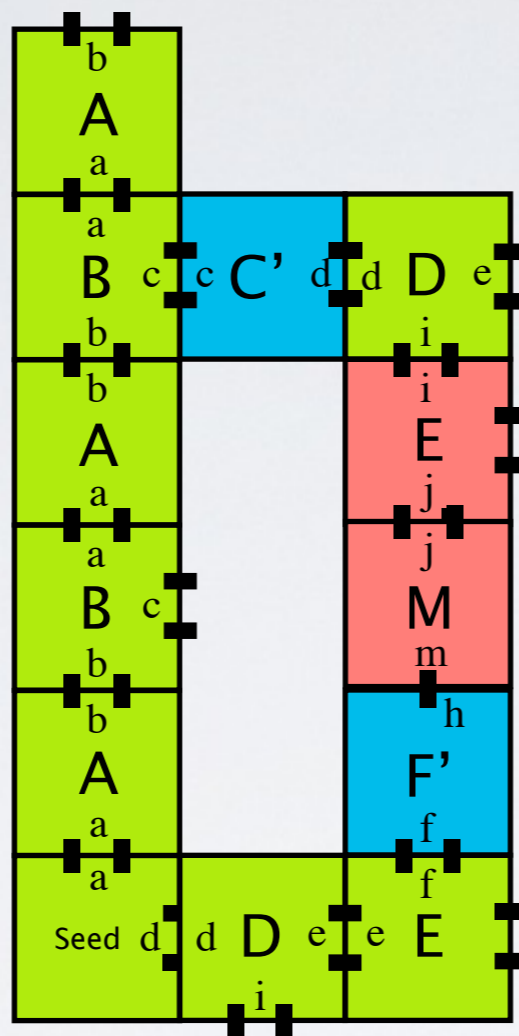
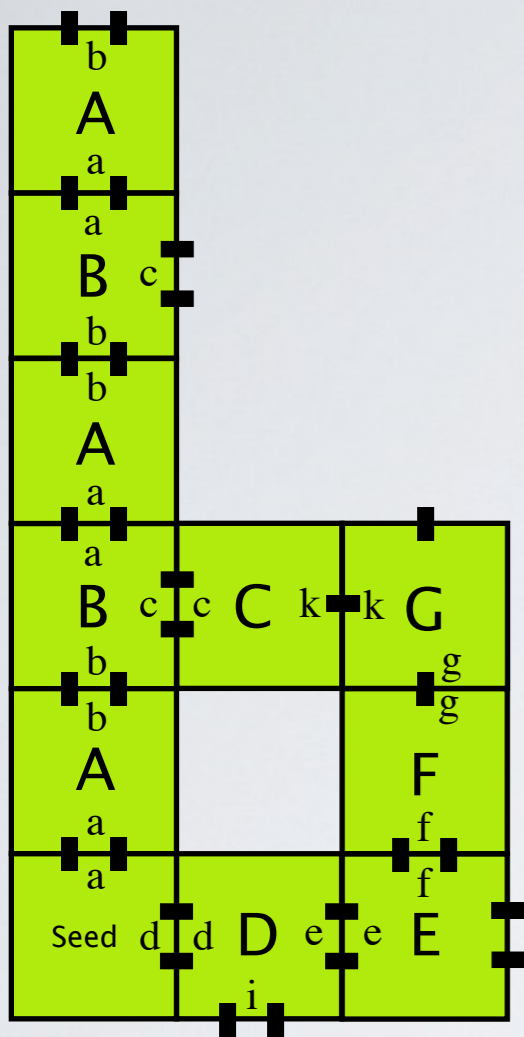

Temperature = 2

Order of tile placement is nondeterministic
(asynchronous growth).

More than one tile type can go at a given position

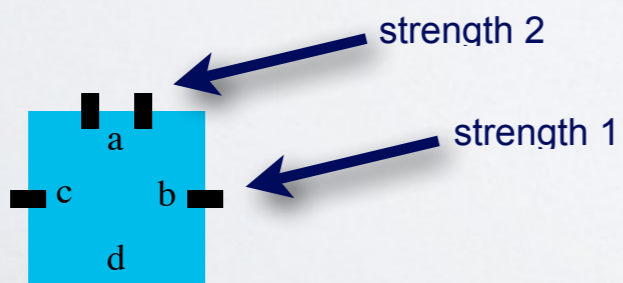

- Finite set of square **tiles**, each side has a **glue** and **strength**
- **Tile assembly system**: [tile set, seed tile, temperature (0,1,2,3,...)]
- Growth begins from the **seed** tile/assembly
- A tile **sticks** to an assembly if enough of its glues match so that the sum of the strengths of the matching glues is at least the **temperature**

Abstract tile assembly model

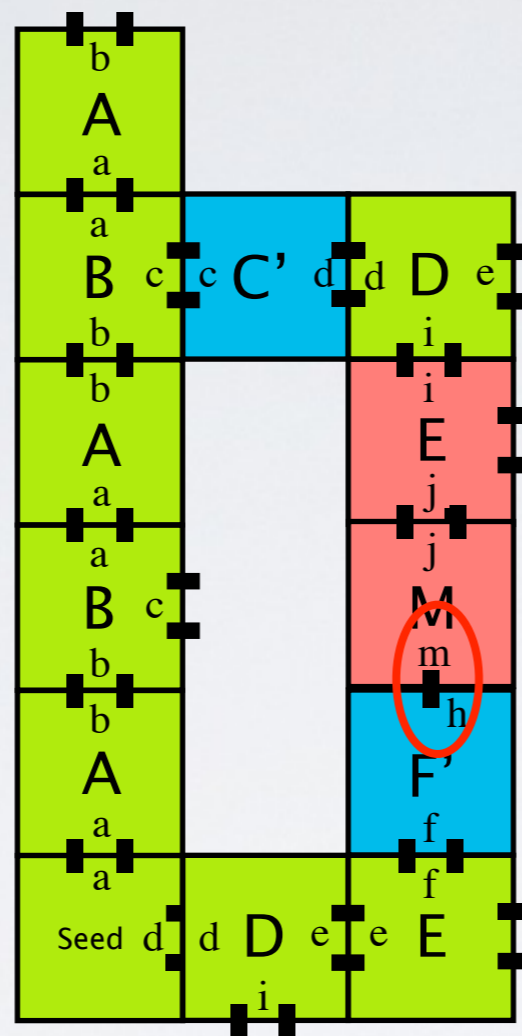
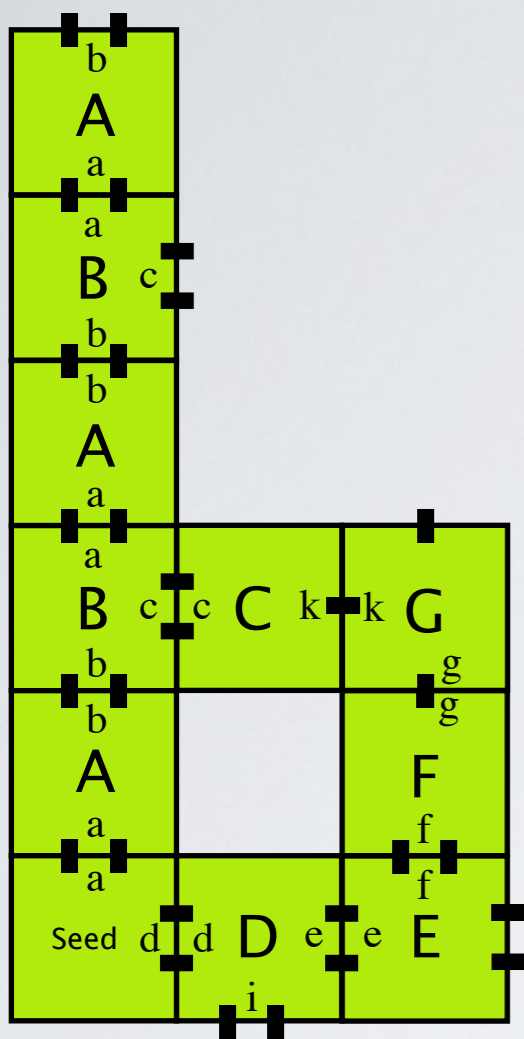

Mismatching glues are permitted

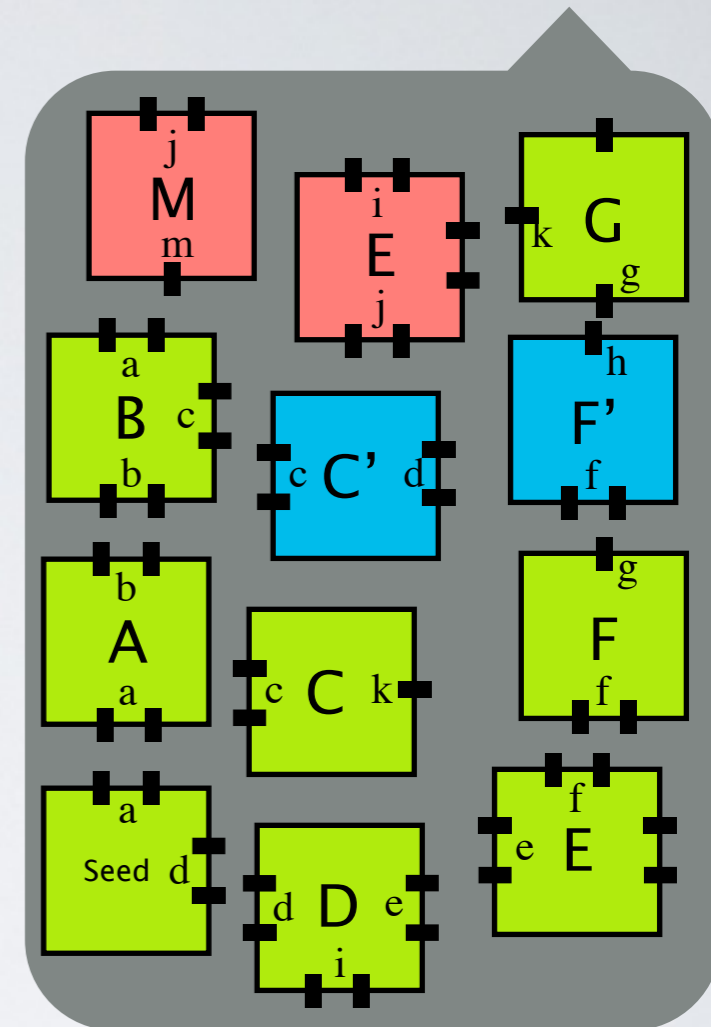

Temperature = 2

Order of tile placement is nondeterministic (asynchronous growth).

More than one tile type can go at a given position

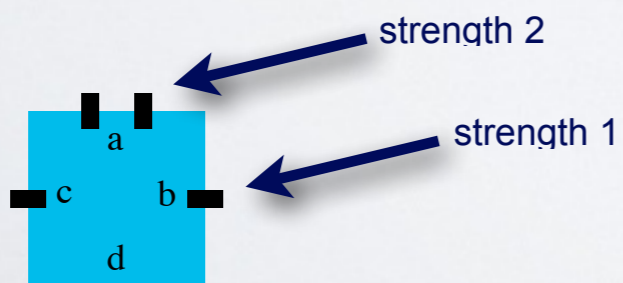

- Finite set of square **tiles**, each side has a **glue** and **strength**
- **Tile assembly system**: [tile set, seed tile, temperature (0,1,2,3,...)]
- Growth begins from the **seed** tile/assembly
- A tile **sticks** to an assembly if enough of its glues match so that the sum of the strengths of the matching glues is at least the **temperature**

Computation with tile assembly

- Turing universality

Winfree, 1998

- Efficient assembly of simple shapes

- E.g. $n \times n$ squares using $\Theta(\log n / \log \log n)$ tile types

Adleman, Cheng, Goel, Huang STOC 2001

Rothemund, Winfree. STOC 2000

- Efficient assembly of complicated connected shapes using a number of tile types roughly equal to the Kolmogorov complexity of the shape

Soloveichik, Winfree. SICOMP 2007

Intrinsic universality

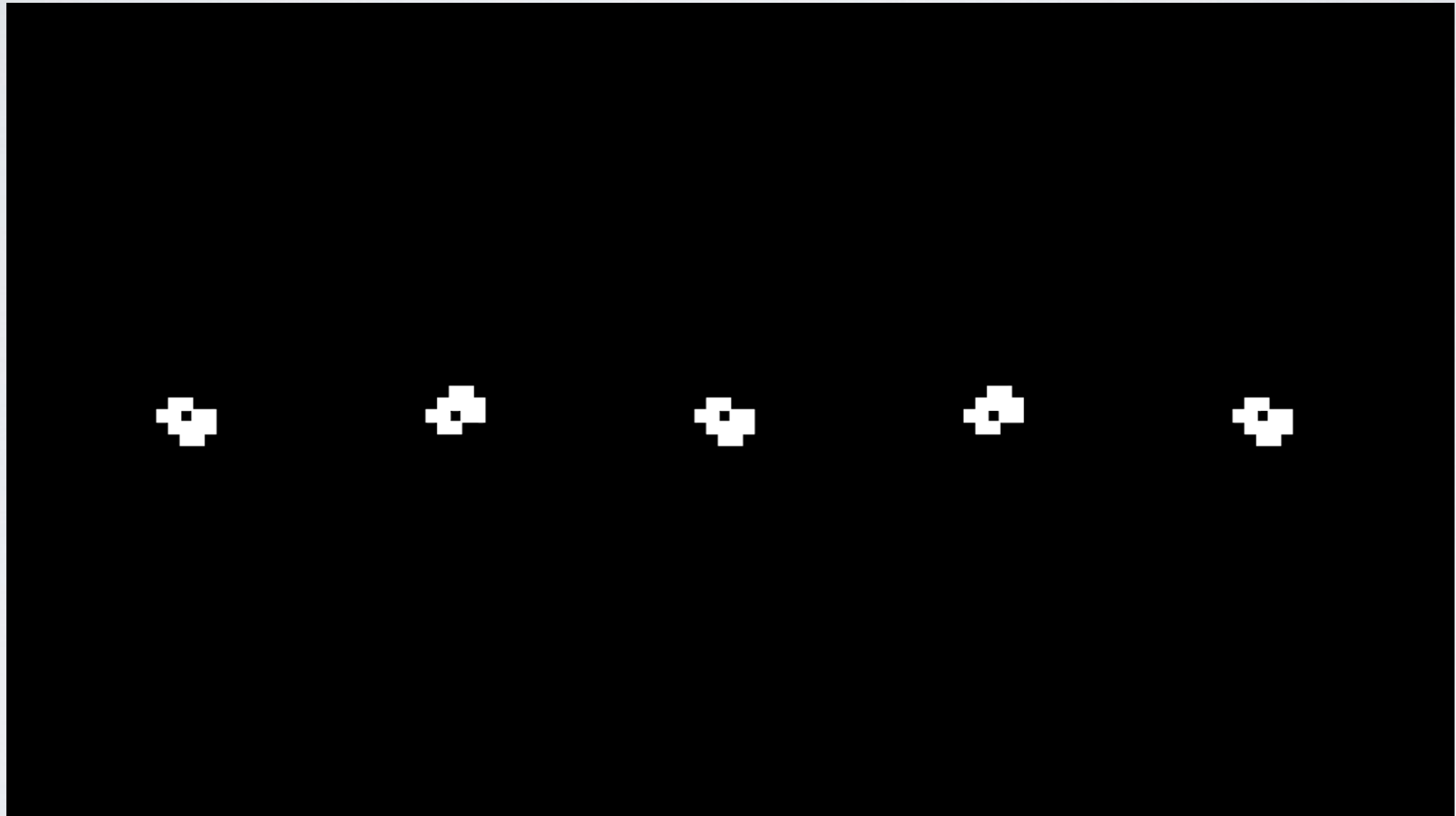

<http://otcametapixel.blogspot.com/>
<http://www.youtube.com/watch?v=xP5-ileKXE8>

Intrinsic universality

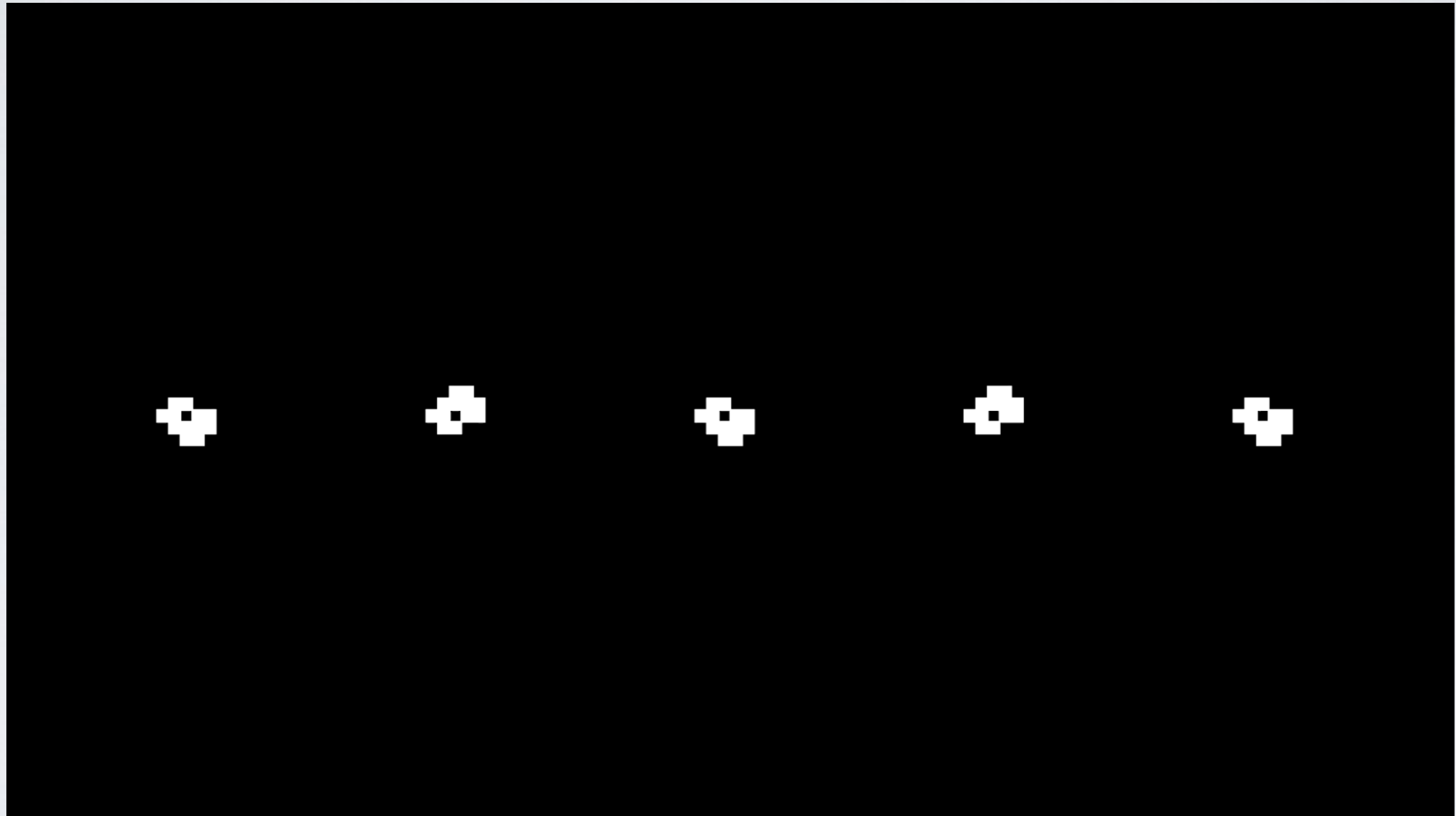

<http://otcametapixel.blogspot.com/>
<http://www.youtube.com/watch?v=xP5-ileKXE8>

Intrinsic universality

- Simulation
- Conway's Game of Life is an intrinsically universal cellular automaton

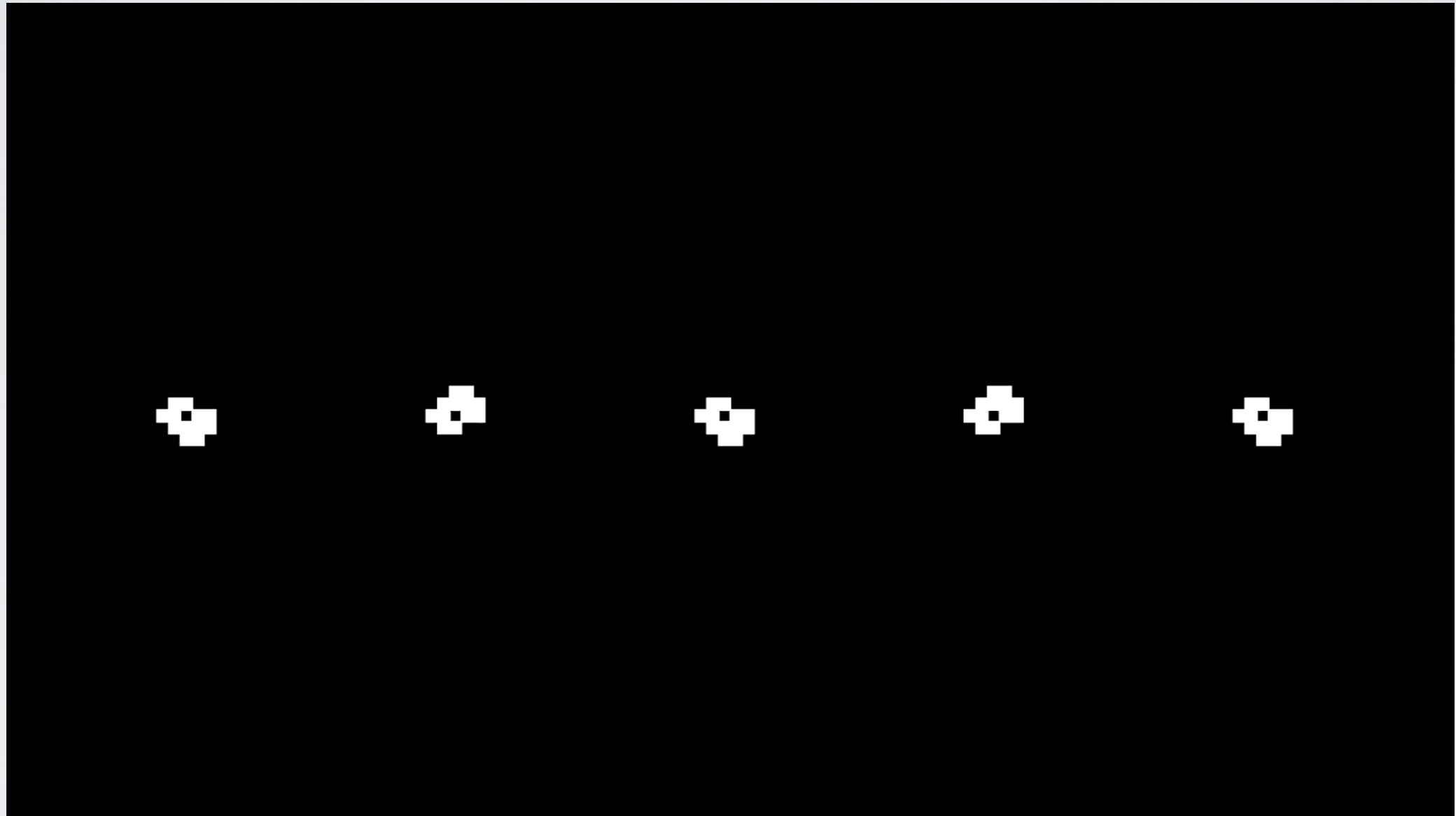

<http://otcametapixel.blogspot.com/>

<http://www.youtube.com/watch?v=xP5-ileKXE8>

Durand, Roka, The game of life: universality revisited. 1999

Intrinsic universality

- An intrinsically universal CA is one that “simulates” any other:

- Appropriate encoding into $k \times k$ blocks
- Encodes all (!) properties of the simulated CA, up to $k \times k$ rescaling

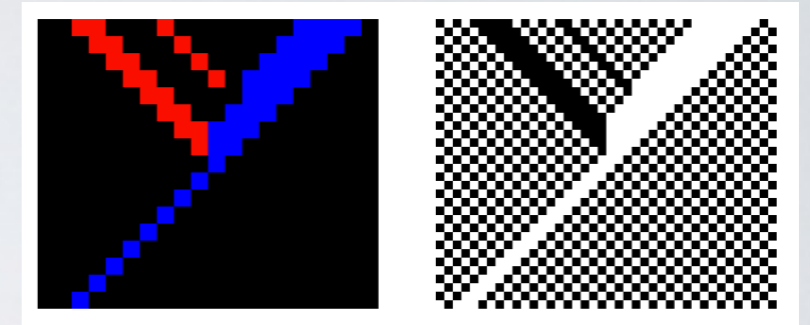

“Just gliders”

Rule 184

Rule 184 simulates “Just gliders” via a time and space rescaling (encoding) Stolen, and vertically flipped, from G. Theyssier’s slides

- Theory of intrinsic universality in CA

- Applications:

- separating class of cellular automata based on their simulation abilities
- use of non-intrinsic universality results to prove that certain cellular automata are “computationally weak”

Is the abstract tile assembly model
intrinsically universal?

Is the abstract tile assembly model
intrinsically universal?

Is there is a single tile set that
simulates *any* tile assembly system?

Is the abstract tile assembly model
intrinsically universal?

Is there is a single tile set that
simulates *any* tile assembly system?

Yes!

Is the abstract tile assembly model intrinsically universal?

Is there is a single tile set that
simulates *any* tile assembly system?

Yes!

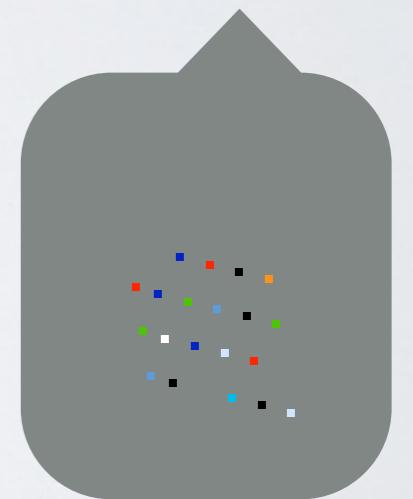

Temperature = 2

**Universal
tile set**

Doty, Lutz, Patitz, Schweller, Summers, Woods. FOCS 2012

Our journey



aTAM, $\tau \geq 2$ (IU [11])

Simulation definition

- We want a definition of simulation that captures the notion of one tile assembly system simulating the “behaviour” of another
- \mathcal{T} is a (any) simulated tile assembly system,
 - $\mathcal{T} = (\text{tileset } T, \text{ seed assembly } \sigma, \text{ temperature } \tau)$
- Tile assembly system $\mathcal{U}_\tau = (U, \sigma_\tau, 2)$ simulates \mathcal{T} if:
 - Tiles from T are simulated by $m \times m$ **supertiles** in \mathcal{U}_τ
 - **Producible** assemblies in \mathcal{U}_τ represent **exactly the producible** assemblies in \mathcal{T} .
 - **Dynamics are equivalent** in \mathcal{U}_τ & \mathcal{T} , ignoring $m \times m$ scaling

Simulation definition

Universal
(simulator)
tile set

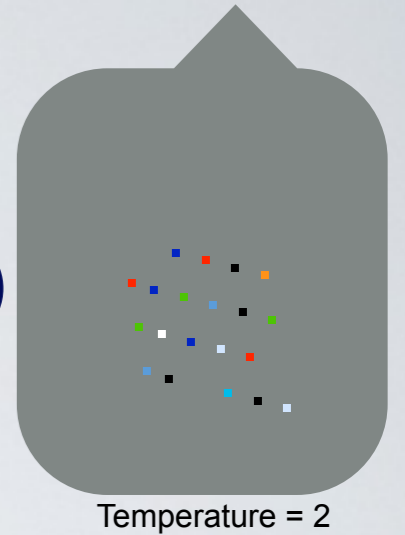

Simulated
tile

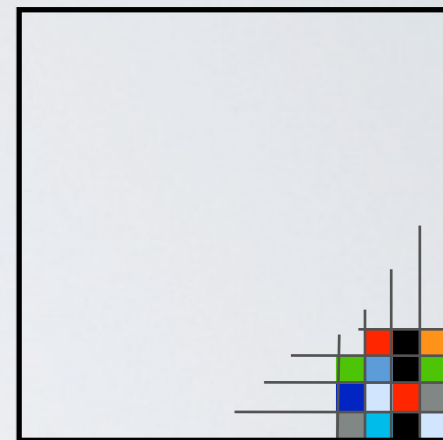
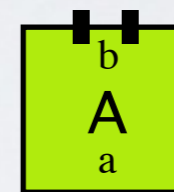

Simulator
supertile

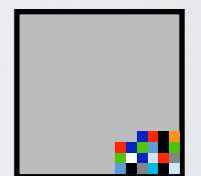

\mathcal{T}

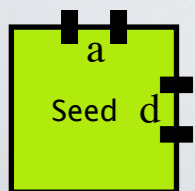

Preassembled
seed structure
(encodes simulated
TAS)

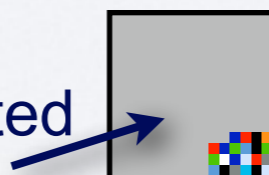

\mathcal{U}

- Green tiles are simulated by supertiles
- For each assembly sequence in the simulated tile system, there is an assembly sequence in the simulator, and vice-versa

Simulation definition

Universal
(simulator)
tile set

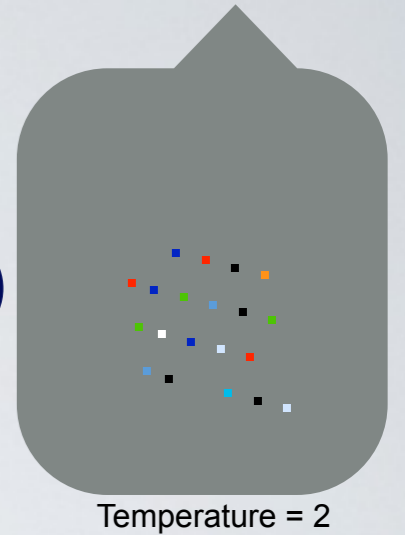

Simulated
tile

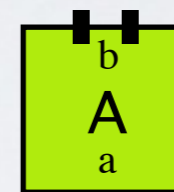

Simulator
supertile

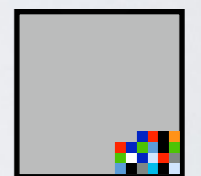

Preassembled
seed structure
(encodes simulated
TAS)

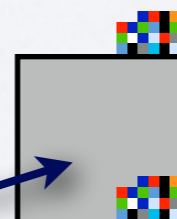

T

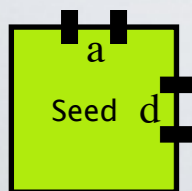

U

- Green tiles are simulated by supertiles
- For each assembly sequence in the simulated tile system, there is an assembly sequence in the simulator, and vice-versa

Simulation definition

Universal
(simulator)
tile set

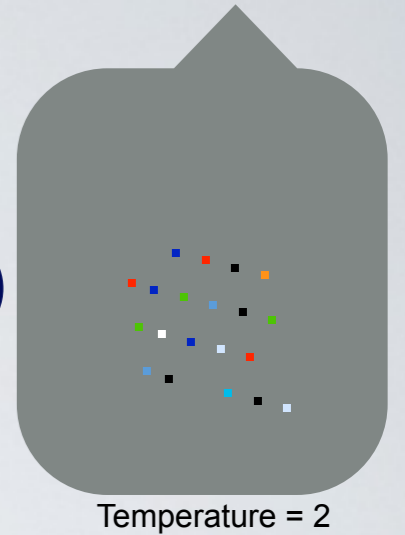

Simulated
tile

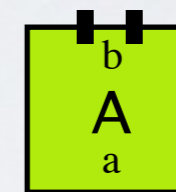

Simulator
supertile

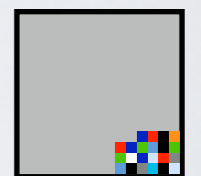

- Green tiles are simulated by supertiles
- For each assembly sequence in the simulated tile system, there is an assembly sequence in the simulator, and vice-versa

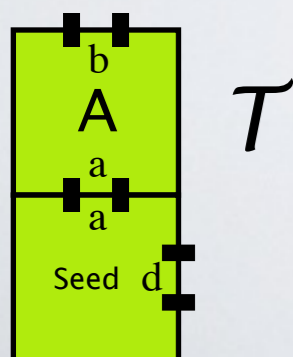

Preassembled
seed structure
(encodes simulated
TAS)



\mathcal{U}

Simulation definition

Universal
(simulator)
tile set

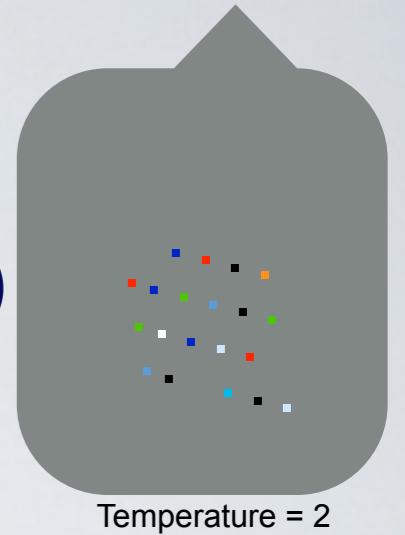

Simulated
tile

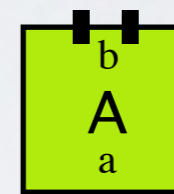

Simulator
supertile

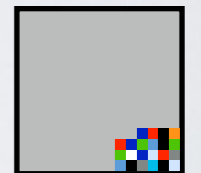

- Green tiles are simulated by supertiles
- For each assembly sequence in the simulated tile system, there is an assembly sequence in the simulator, and vice-versa

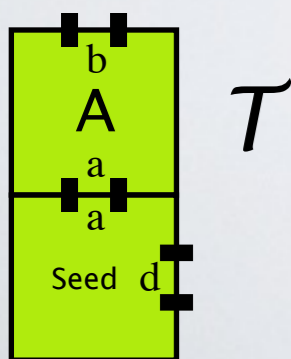

Preassembled
seed structure
(encodes simulated
TAS)

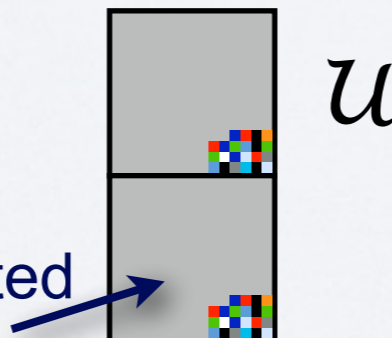

Simulation definition

Universal
(simulator)
tile set

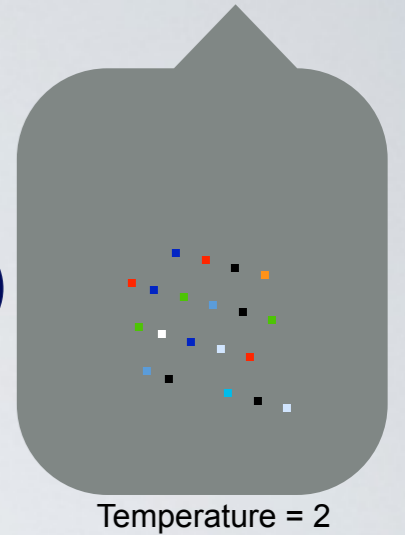

Simulated
tile

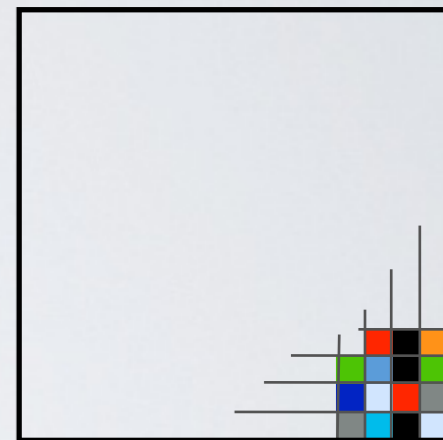
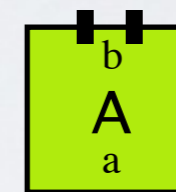

Simulator
supertile

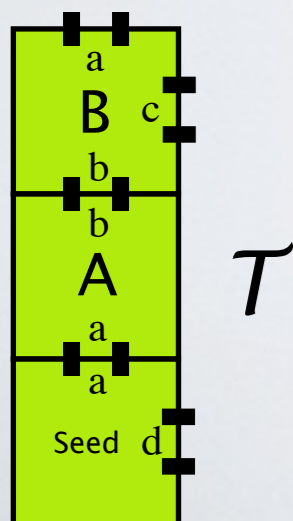
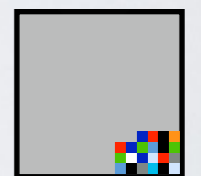

Preassembled
seed structure
(encodes simulated
TAS)

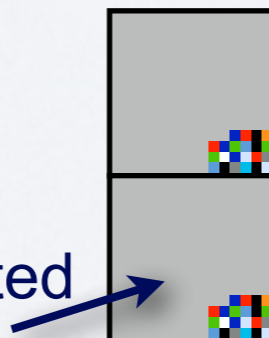

\mathcal{U}

- Green tiles are simulated by supertiles
- For each assembly sequence in the simulated tile system, there is an assembly sequence in the simulator, and vice-versa

Simulation definition

Universal
(simulator)
tile set

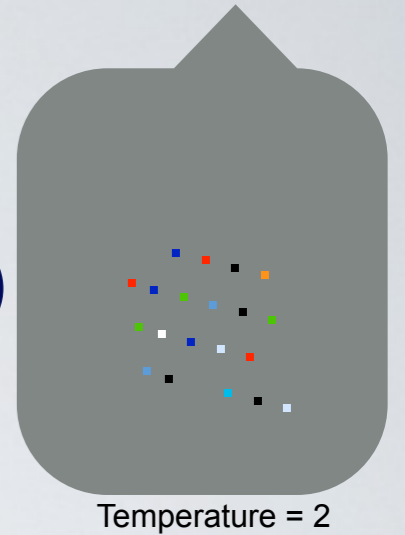

Simulated
tile

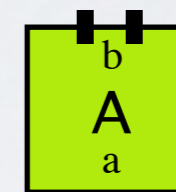

Simulator
supertile

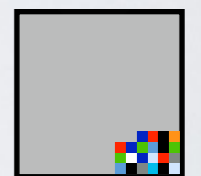

- Green tiles are simulated by supertiles
- For each assembly sequence in the simulated tile system, there is an assembly sequence in the simulator, and vice-versa

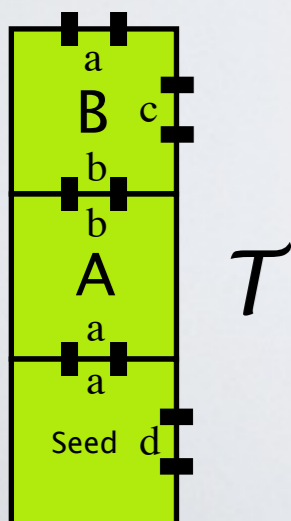

Preassembled
seed structure
(encodes simulated
TAS)

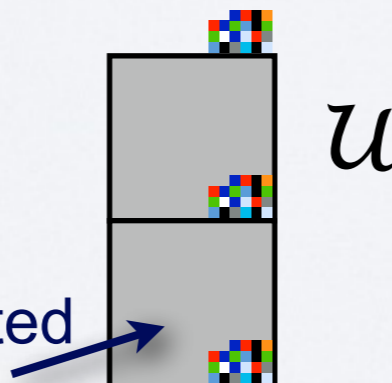

Simulation definition

Universal
(simulator)
tile set

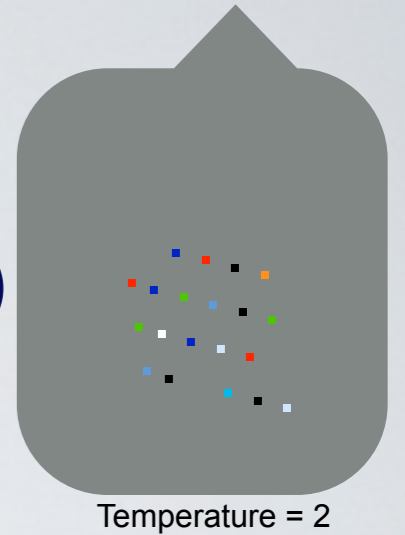

Simulated
tile

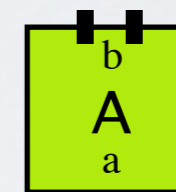

Simulator
supertile

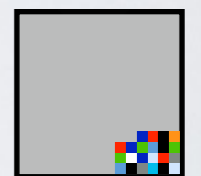

- Green tiles are simulated by supertiles
- For each assembly sequence in the simulated tile system, there is an assembly sequence in the simulator, and vice-versa

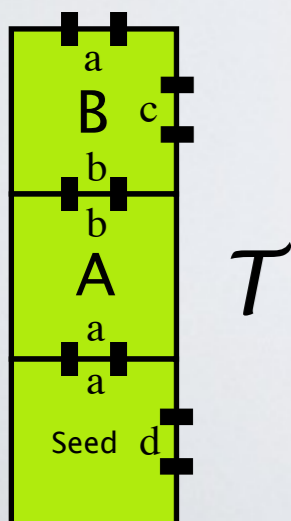

Preassembled
seed structure
(encodes simulated
TAS)

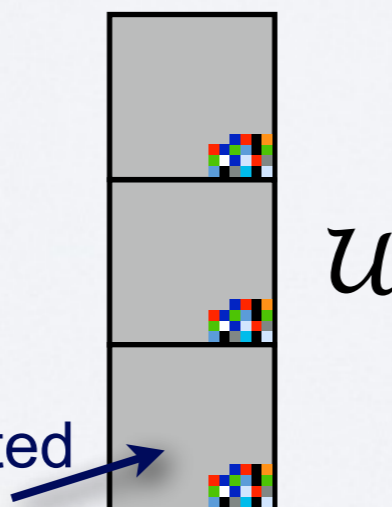

Simulation definition

Universal
(simulator)
tile set

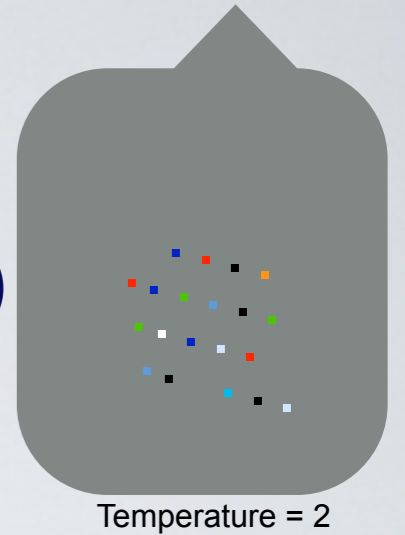

Simulated
tile

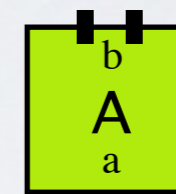

Simulator
supertile

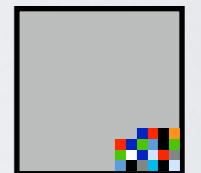

- Green tiles are simulated by supertiles
- For each assembly sequence in the simulated tile system, there is an assembly sequence in the simulator, and vice-versa

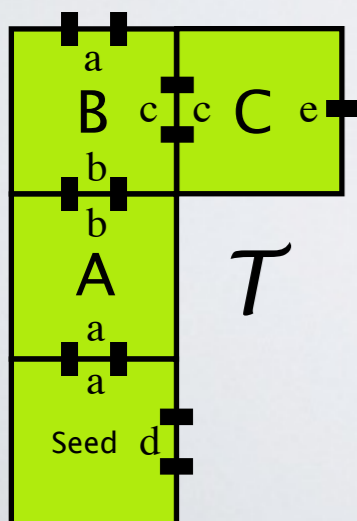

Preassembled
seed structure
(encodes simulated
TAS)

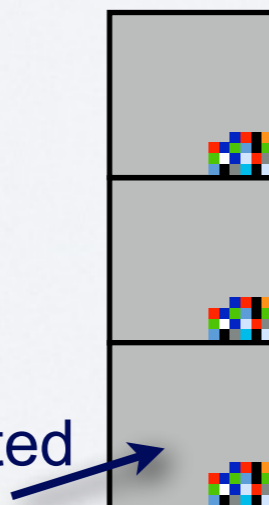

\mathcal{U}

Simulation definition

Universal
(simulator)
tile set

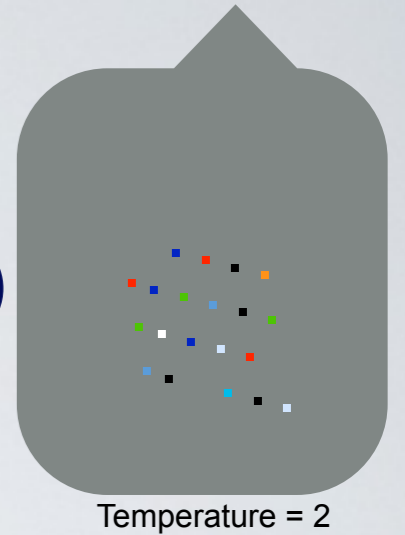

Simulated
tile

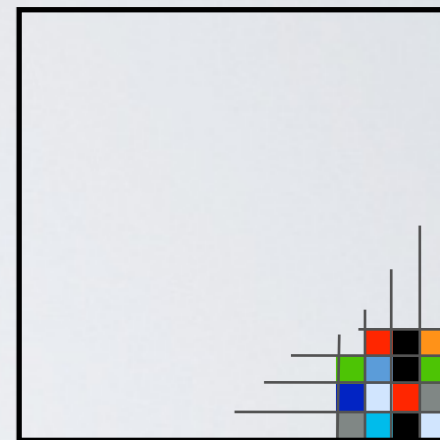
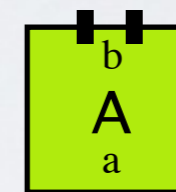

Simulator
supertile

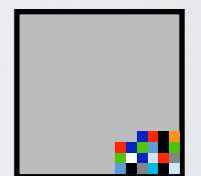

- Green tiles are simulated by supertiles
- For each assembly sequence in the simulated tile system, there is an assembly sequence in the simulator, and vice-versa

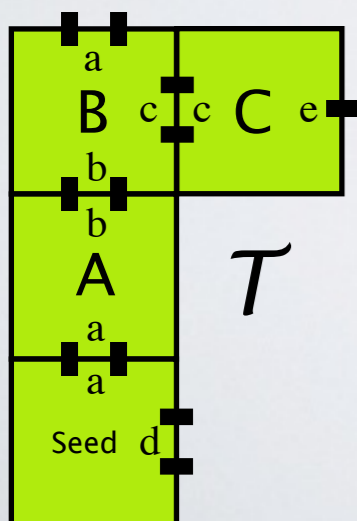

Preassembled
seed structure
(encodes simulated
TAS)

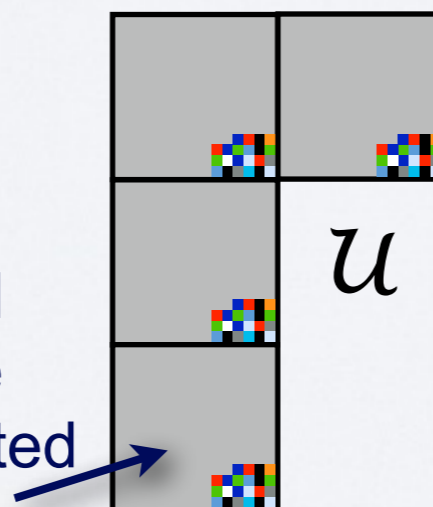

Simulation definition

Universal
(simulator)
tile set

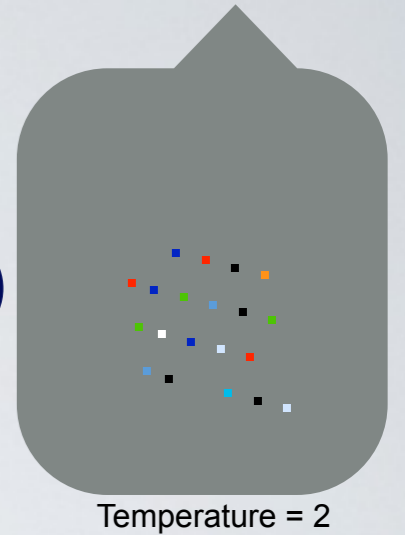

Simulated
tile

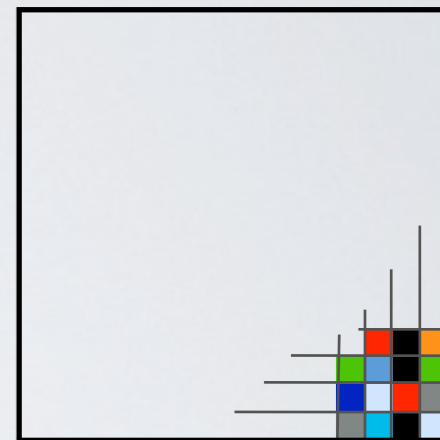
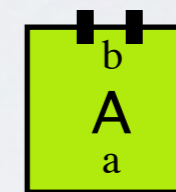

Simulator
supertile

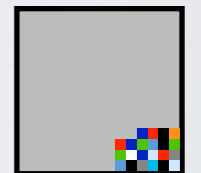

- Green tiles are simulated by supertiles
- For each assembly sequence in the simulated tile system, there is an assembly sequence in the simulator, and vice-versa

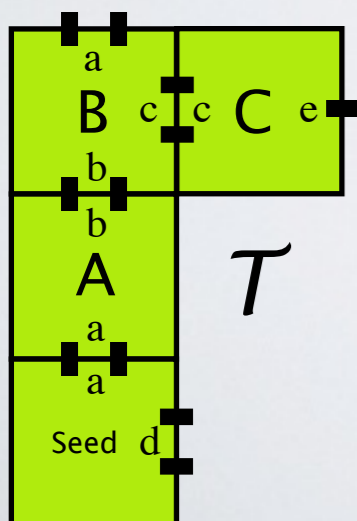

Preassembled
seed structure
(encodes simulated
TAS)

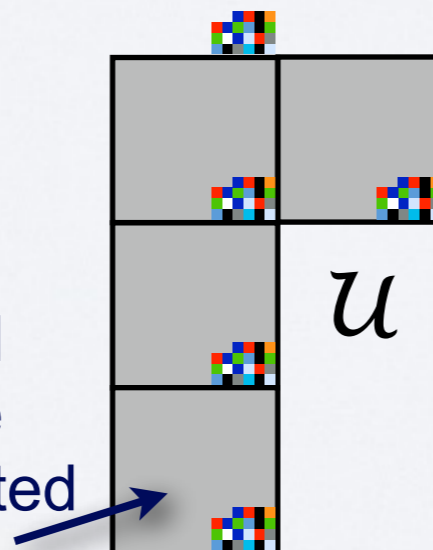

Simulation definition

Universal
(simulator)
tile set

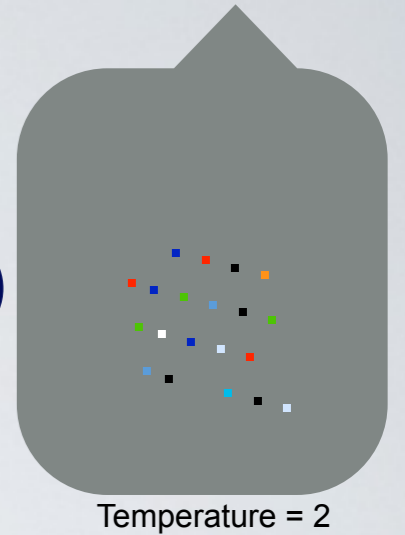

Simulated
tile

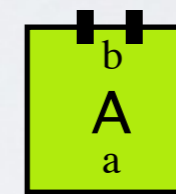

Simulator
supertile

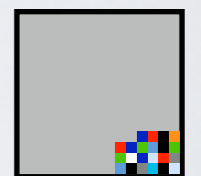

- Green tiles are simulated by supertiles
- For each assembly sequence in the simulated tile system, there is an assembly sequence in the simulator, and vice-versa

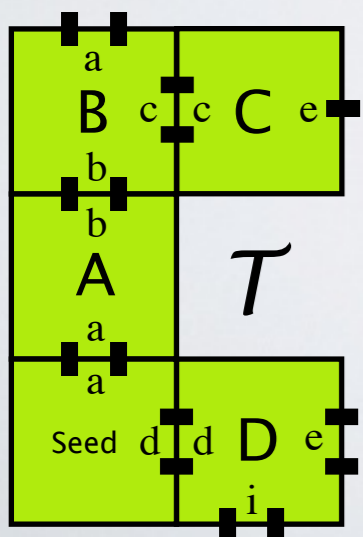

Preassembled
seed structure
(encodes simulated
TAS)

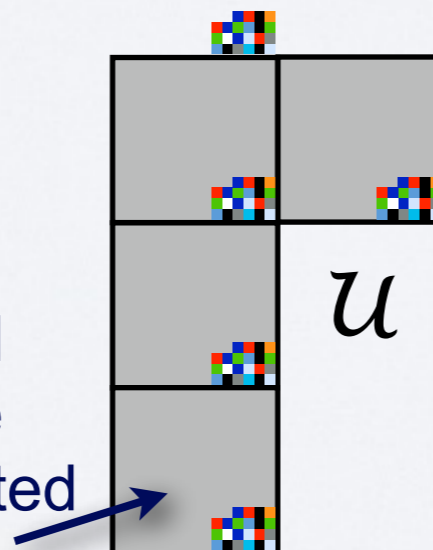

Simulation definition

Universal
(simulator)
tile set

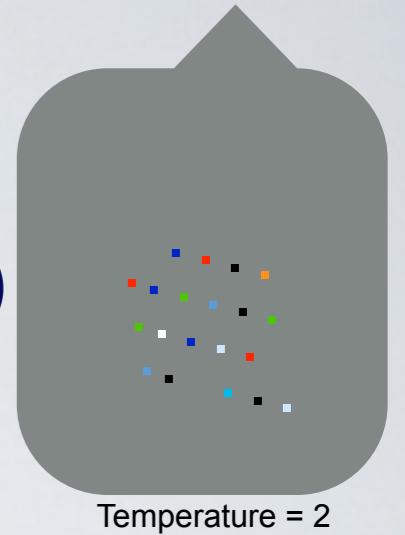

Simulated
tile

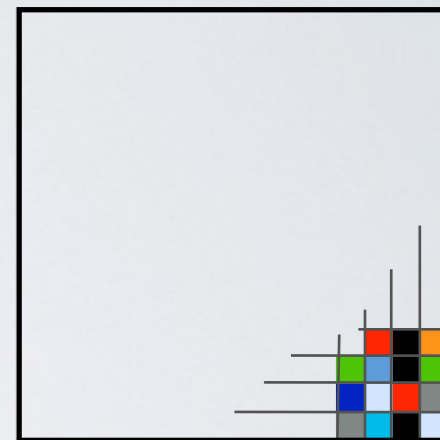
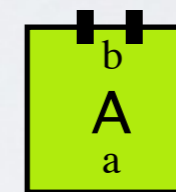

Simulator
supertile

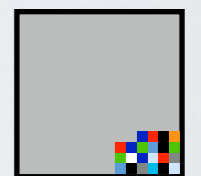

- Green tiles are simulated by supertiles
- For each assembly sequence in the simulated tile system, there is an assembly sequence in the simulator, and vice-versa

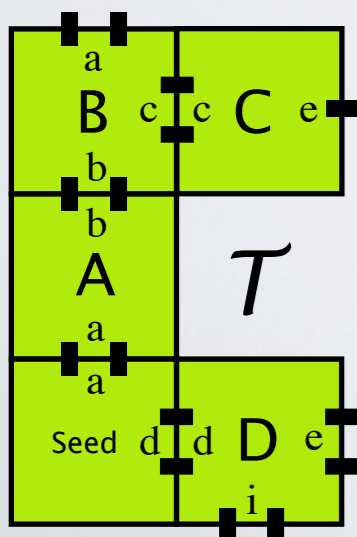

Preassembled
seed structure
(encodes simulated
TAS)

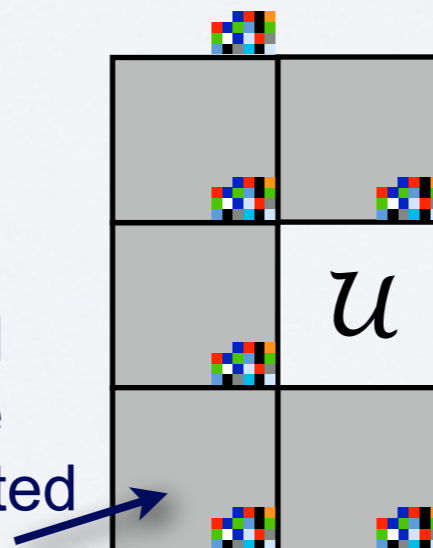

Simulation definition

Universal
(simulator)
tile set

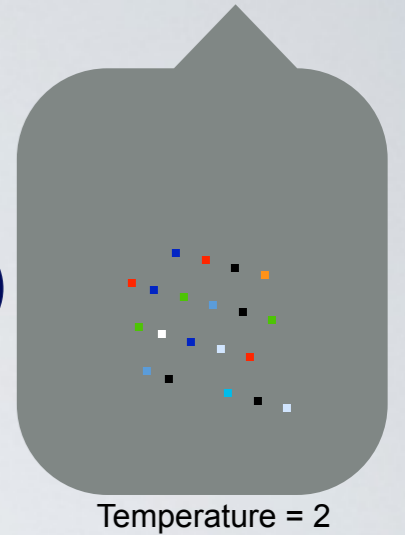

Simulated
tile

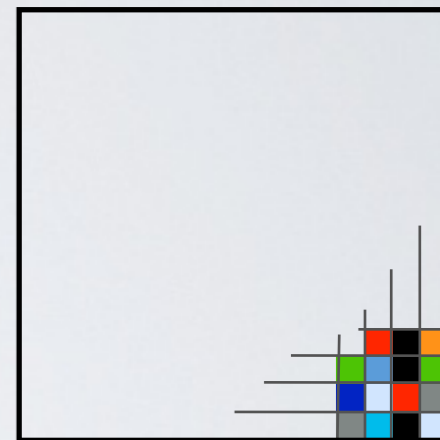
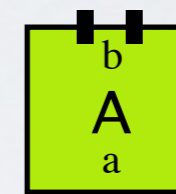

Simulator
supertile

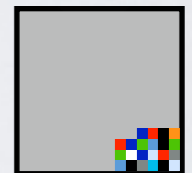

- Green tiles are simulated by supertiles
- For each assembly sequence in the simulated tile system, there is an assembly sequence in the simulator, and vice-versa

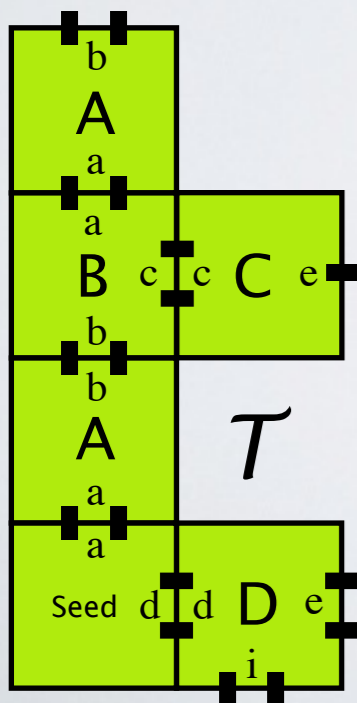

Preassembled
seed structure
(encodes simulated
TAS)

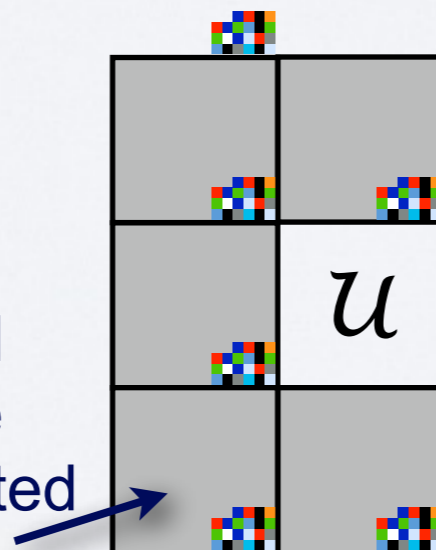

Simulation definition

Universal
(simulator)
tile set

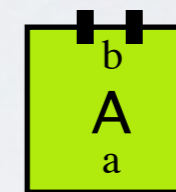
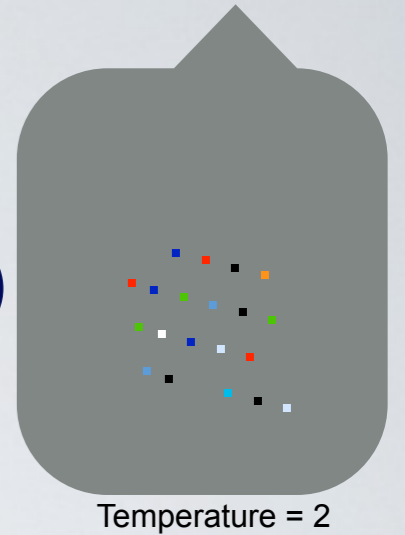

Simulated
tile

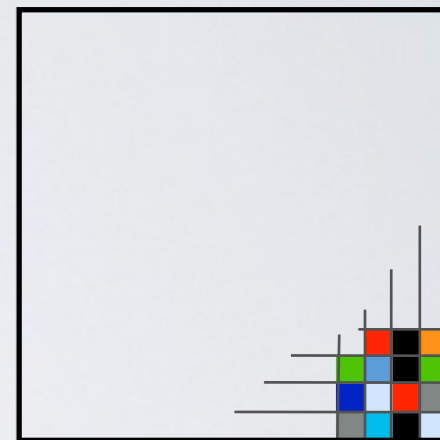

Simulator
supertile

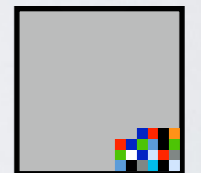

- Green tiles are simulated by supertiles
- For each assembly sequence in the simulated tile system, there is an assembly sequence in the simulator, and vice-versa

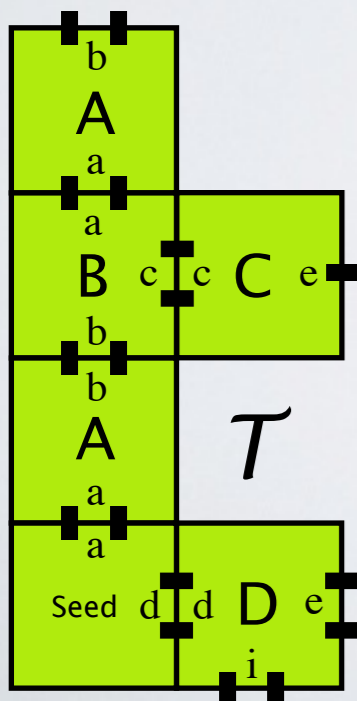

Preassembled
seed structure
(encodes simulated
TAS)

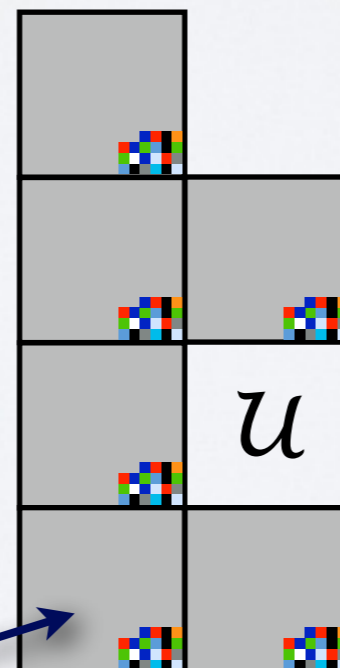

Simulation definition

Universal
(simulator)
tile set

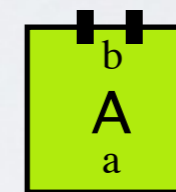
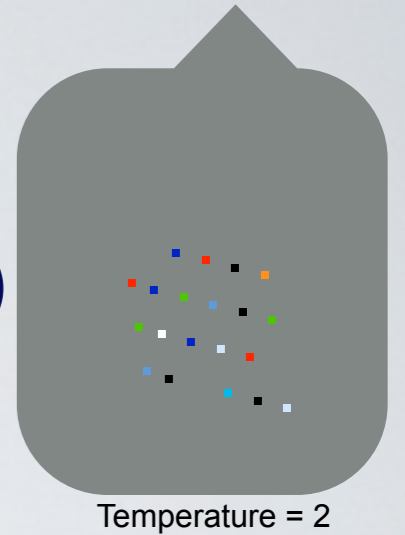

Simulated
tile



Simulator
supertile

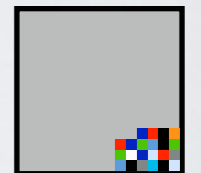

- Green tiles are simulated by supertiles
- For each assembly sequence in the simulated tile system, there is an assembly sequence in the simulator, and vice-versa

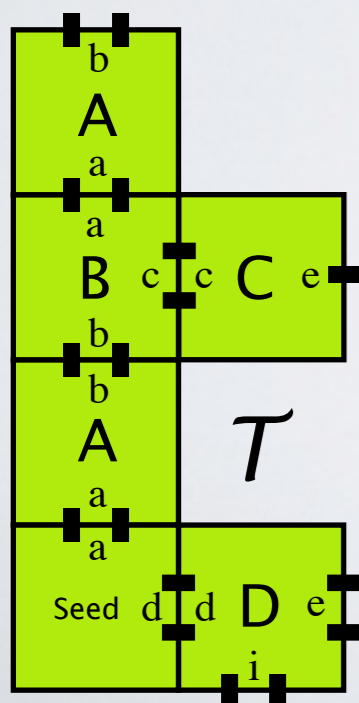

Preassembled
seed structure
(encodes simulated
TAS)

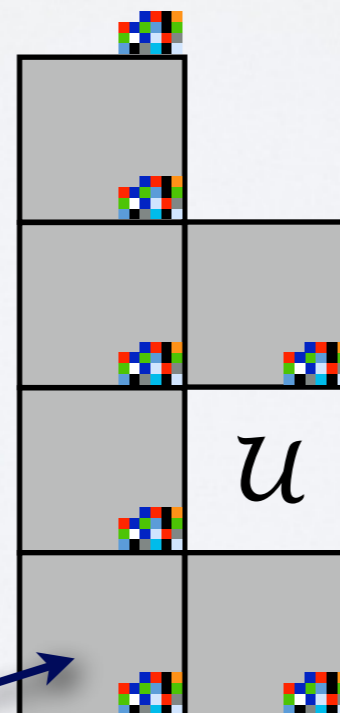

Simulation definition

Universal
(simulator)
tile set

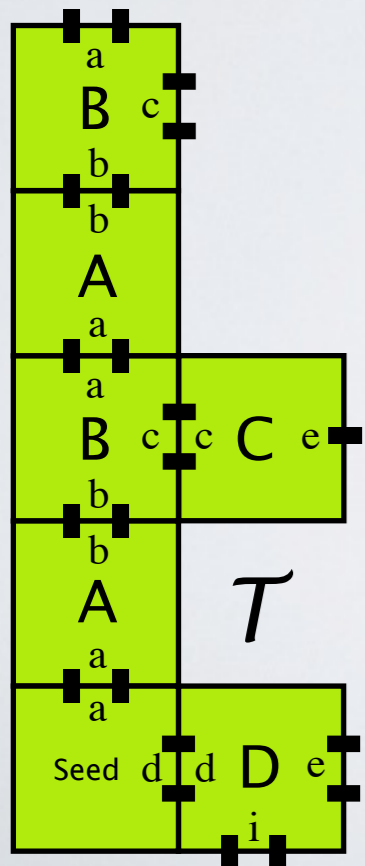
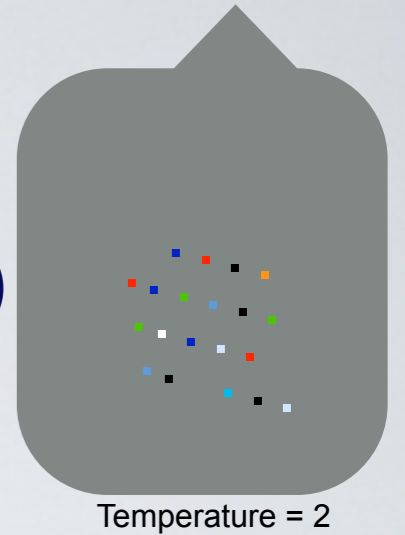

Preassembled
seed structure
(encodes simulated
TAS)

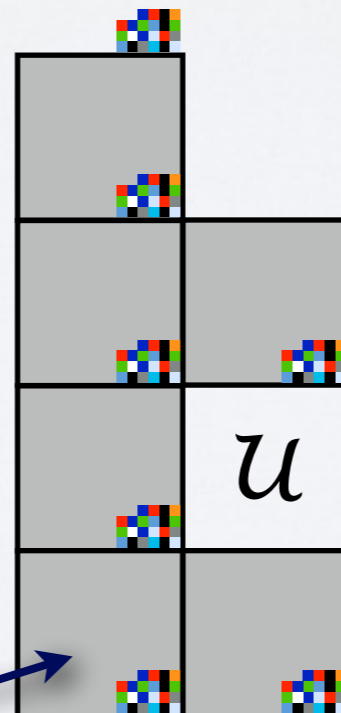

Simulated
tile

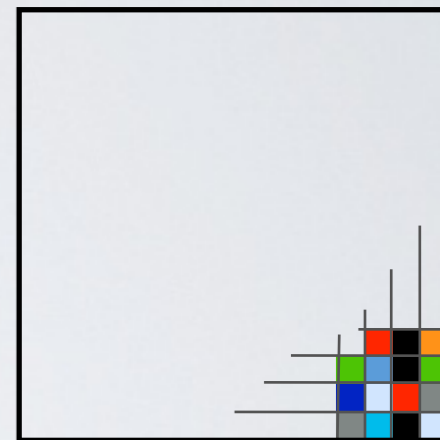
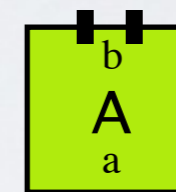

Simulator
supertile

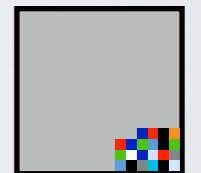

- Green tiles are simulated by supertiles
- For each assembly sequence in the simulated tile system, there is an assembly sequence in the simulator, and vice-versa

Simulation definition

Universal
(simulator)
tile set

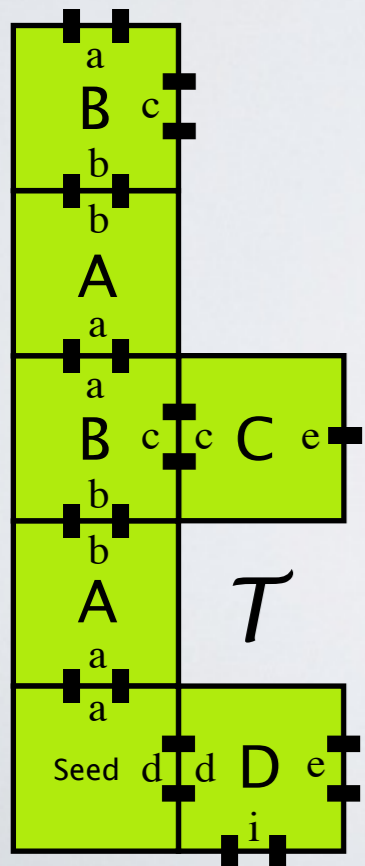
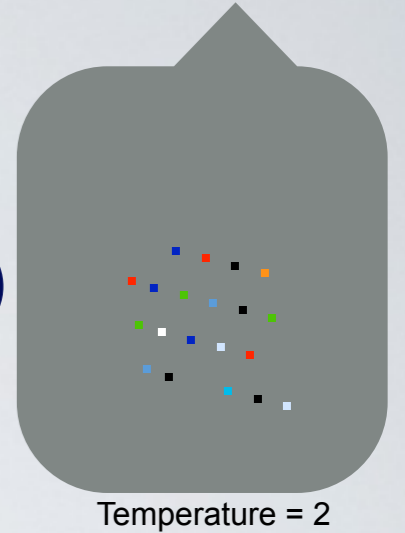

Preassembled
seed structure
(encodes simulated
TAS)

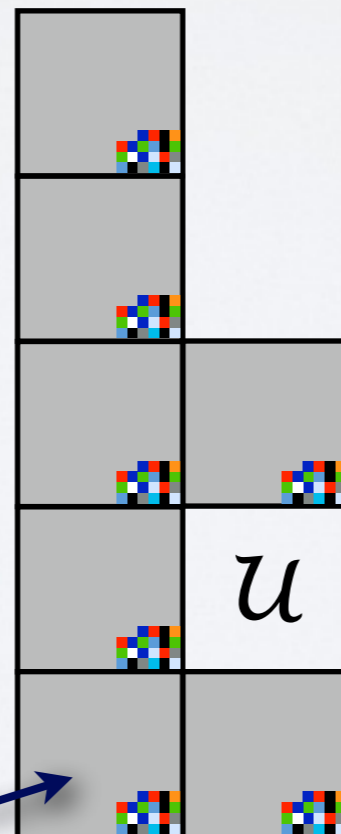

Simulated
tile

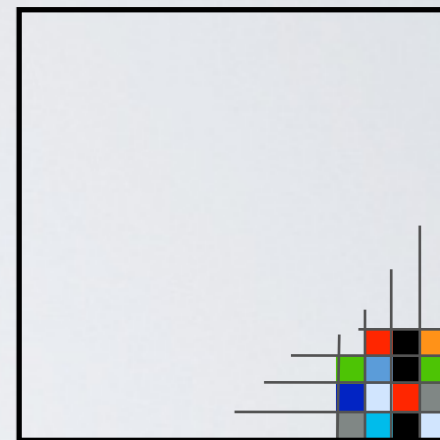
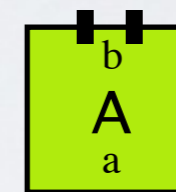

Simulator
supertile

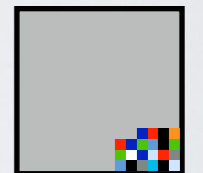

- Green tiles are simulated by supertiles
- For each assembly sequence in the simulated tile system, there is an assembly sequence in the simulator, and vice-versa

Simulation definition

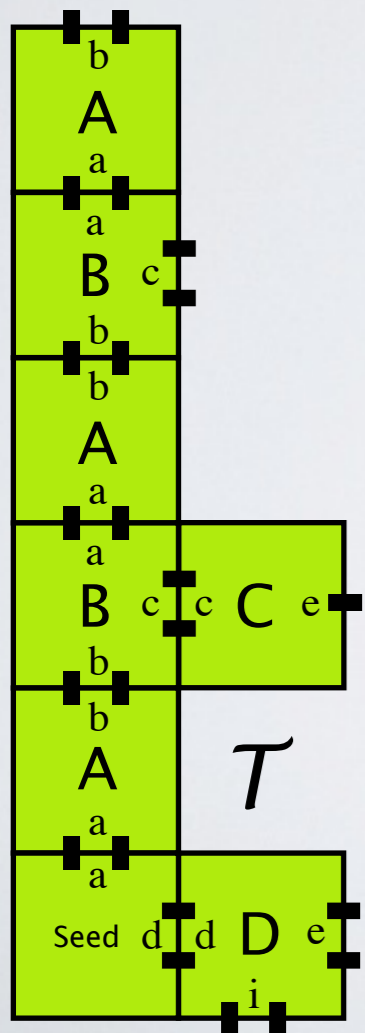

Preassembled seed structure (encodes simulated TAS)

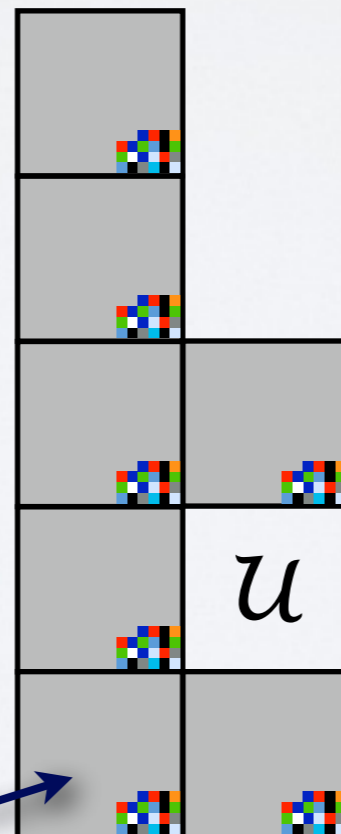

Universal (simulator) tile set

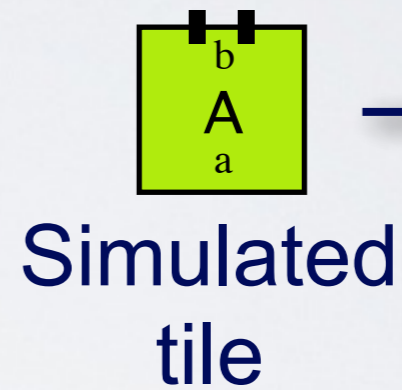
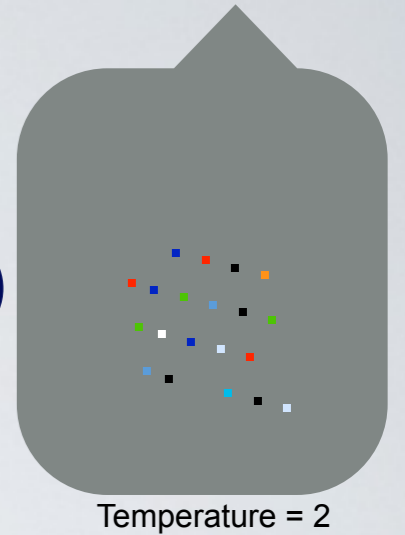

Simulator supertile

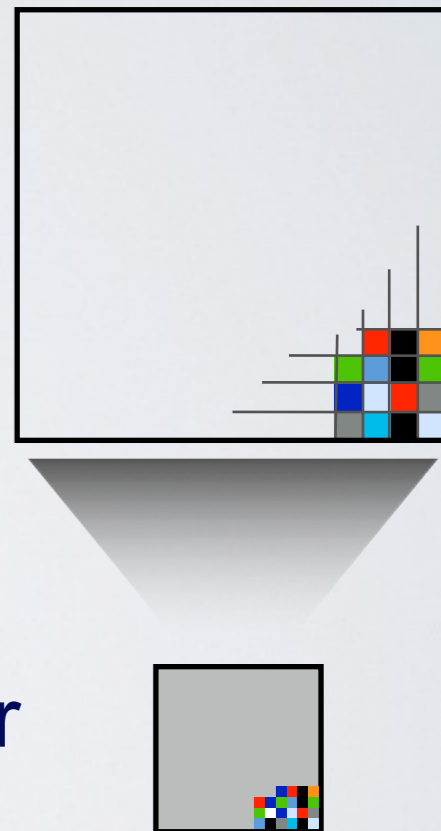

- Green tiles are simulated by supertiles
- For each assembly sequence in the simulated tile system, there is an assembly sequence in the simulator, and vice-versa

Simulation definition

Universal
(simulator)
tile set

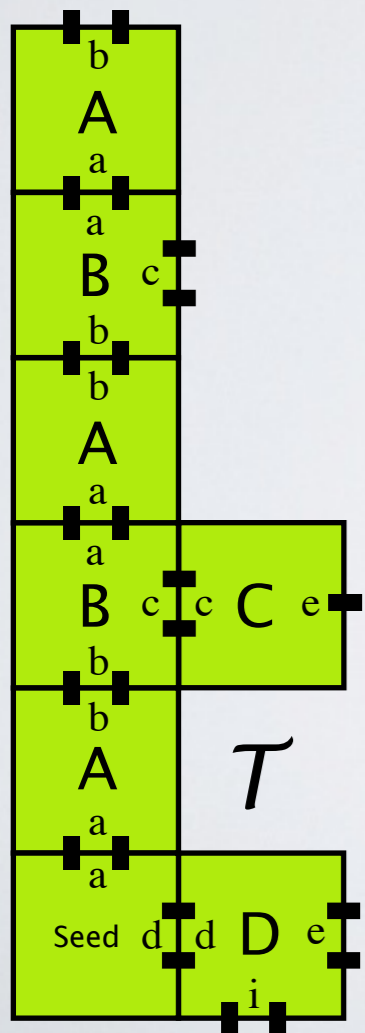
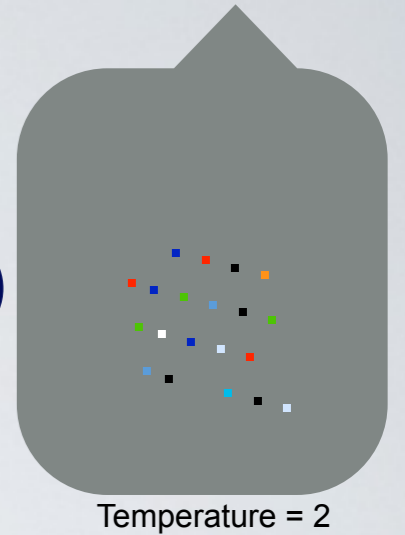

Preassembled
seed structure
(encodes simulated
TAS)

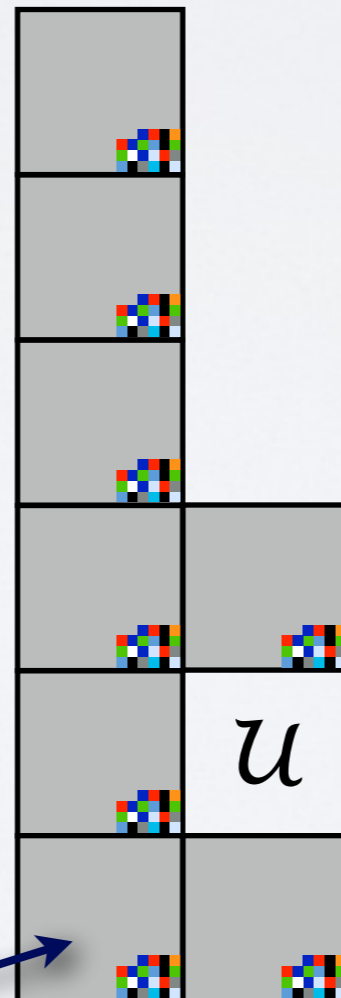

Simulated
tile

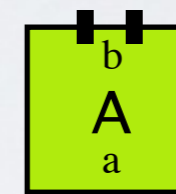

Simulator
supertile

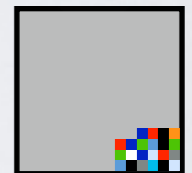

- Green tiles are simulated by supertiles
- For each assembly sequence in the simulated tile system, there is an assembly sequence in the simulator, and vice-versa

Simulation definition

Universal
(simulator)
tile set

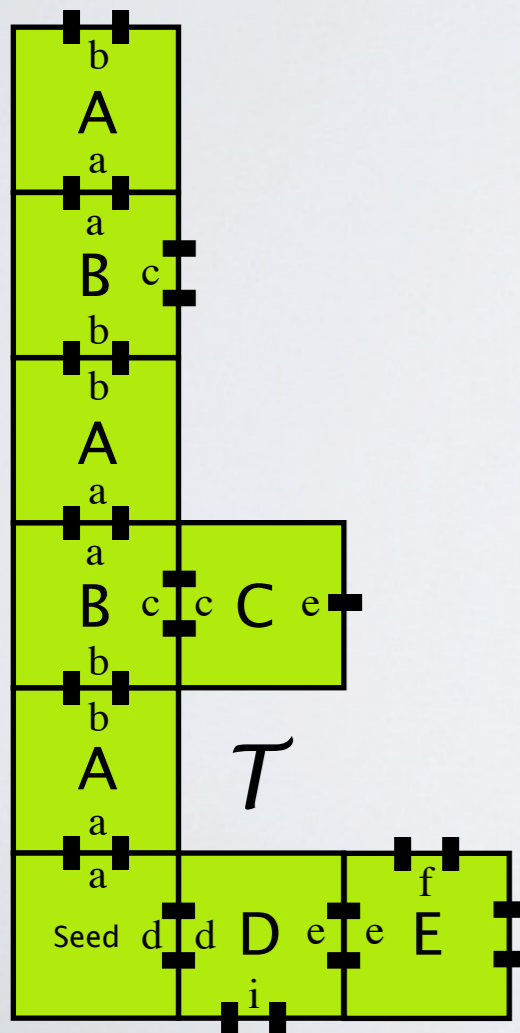
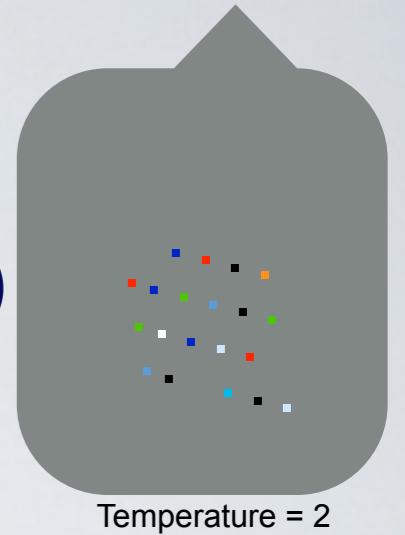

Preassembled
seed structure
(encodes simulated
TAS)

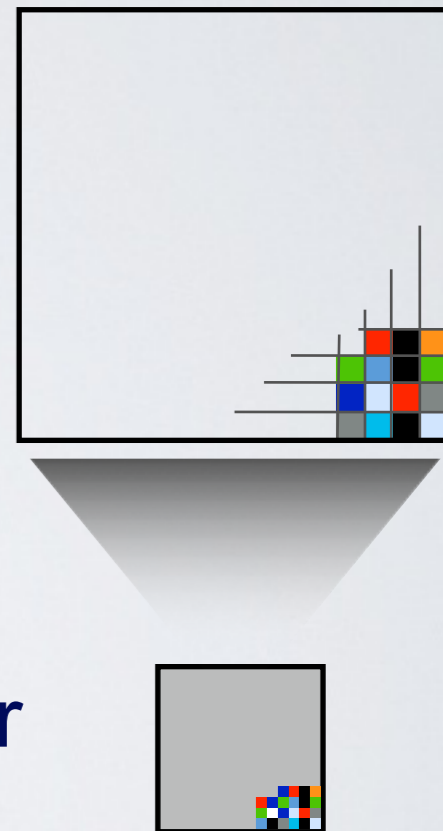
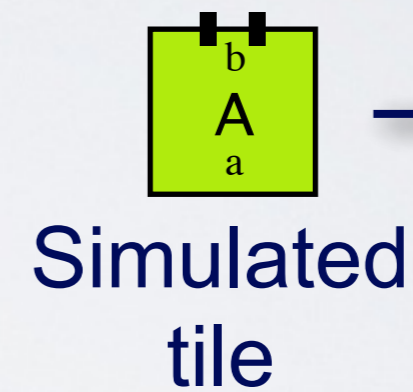
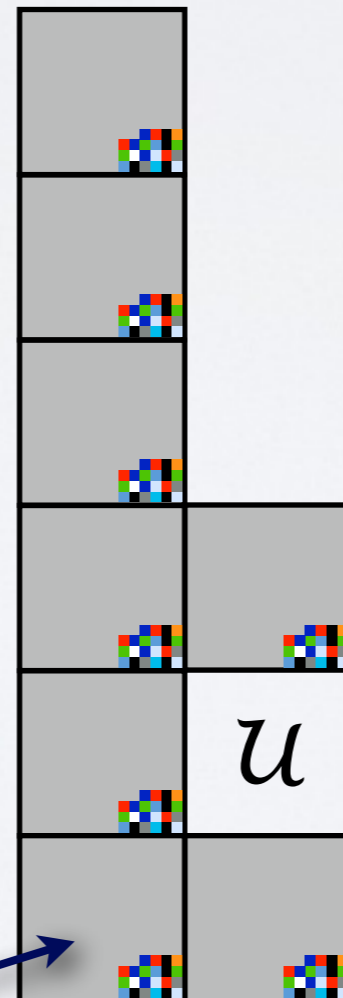

- Green tiles are simulated by supertiles
- For each assembly sequence in the simulated tile system, there is an assembly sequence in the simulator, and vice-versa

Simulation definition

Universal
(simulator)
tile set

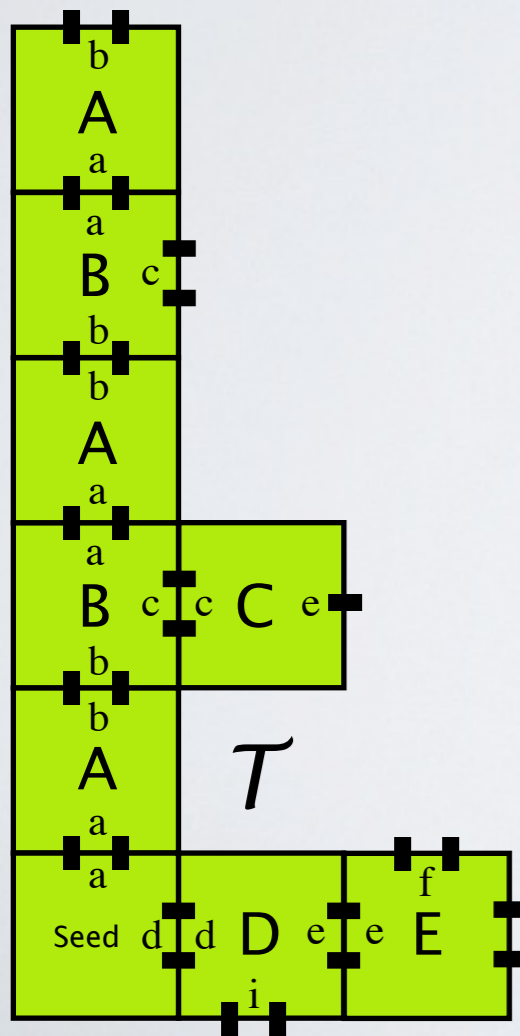
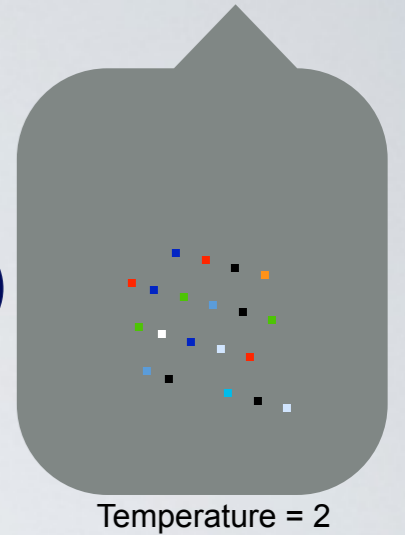

Preassembled
seed structure
(encodes simulated
TAS)

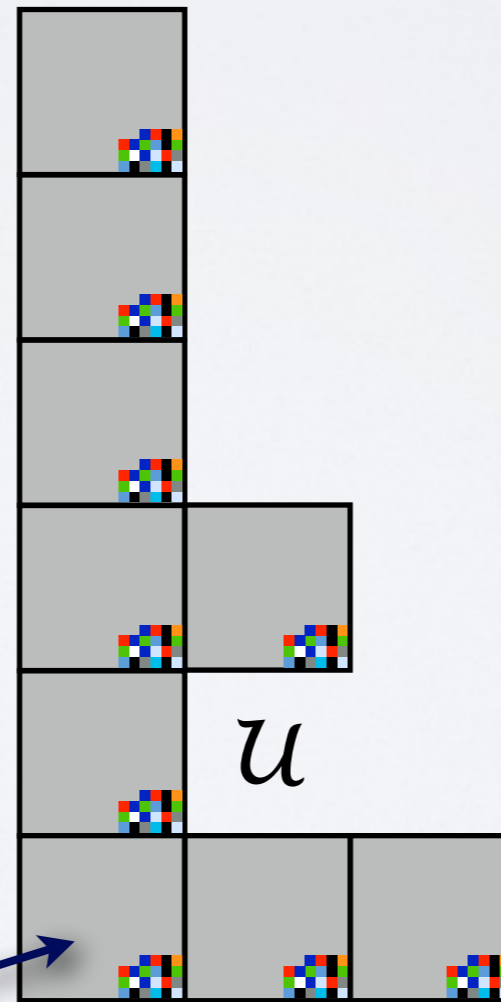

Simulated
tile

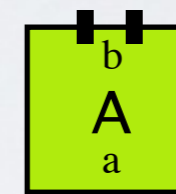

Simulator
supertile

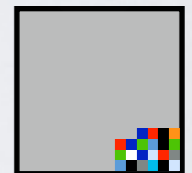

- Green tiles are simulated by supertiles
- For each assembly sequence in the simulated tile system, there is an assembly sequence in the simulator, and vice-versa

Simulation definition

Universal
(simulator)
tile set

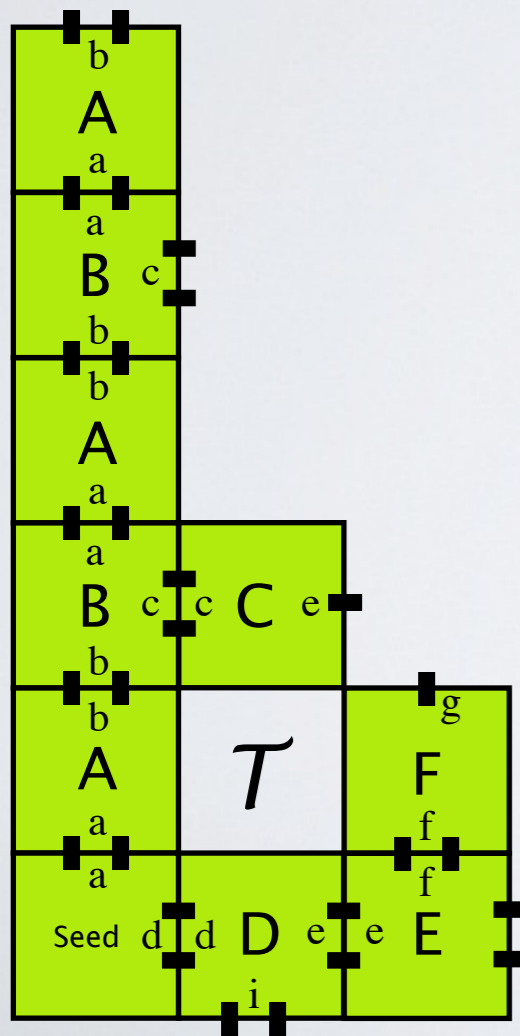
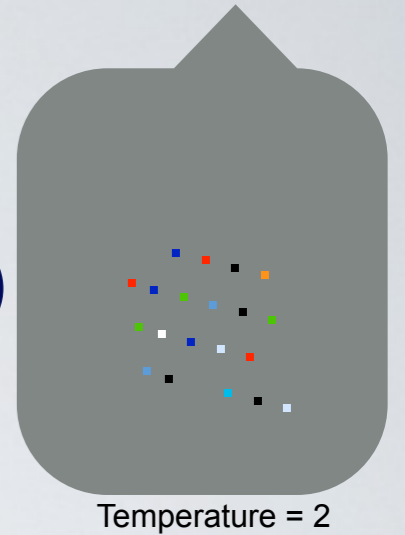

Preassembled
seed structure
(encodes simulated
TAS)

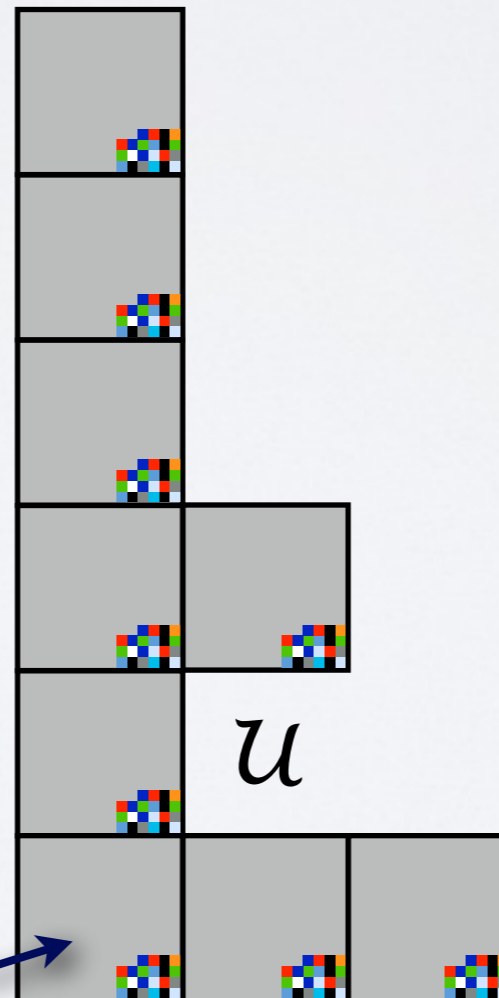

Simulated
tile

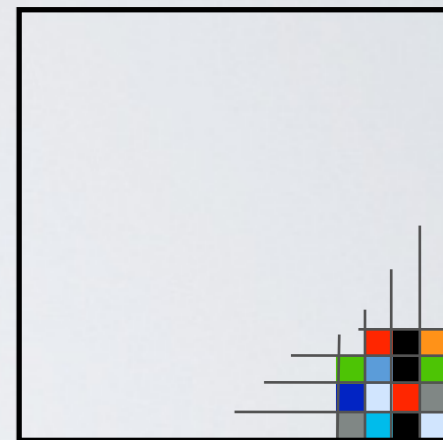
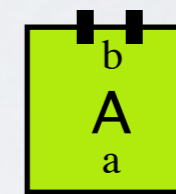

Simulator
supertile

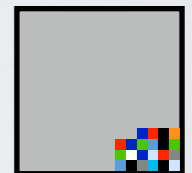

- Green tiles are simulated by supertiles
- For each assembly sequence in the simulated tile system, there is an assembly sequence in the simulator, and vice-versa

Simulation definition

Universal
(simulator)
tile set

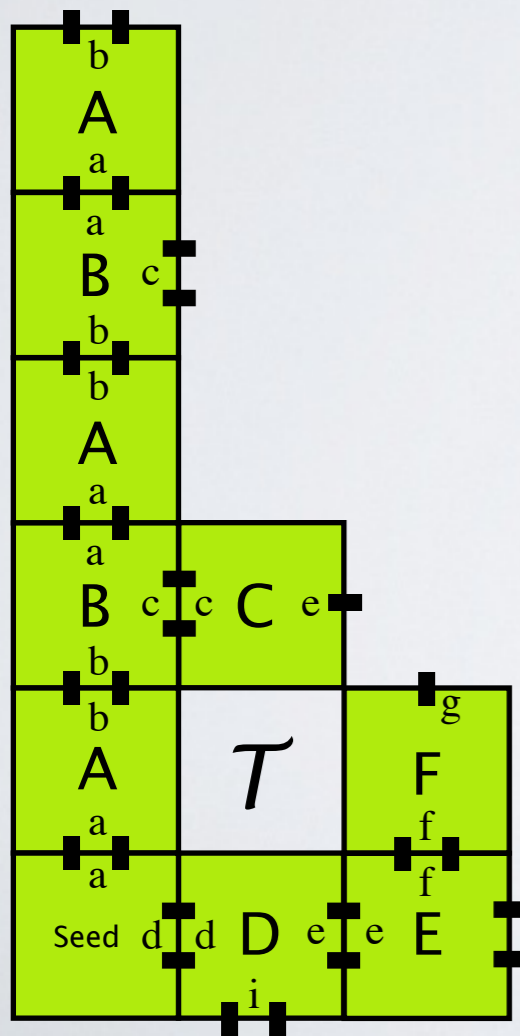
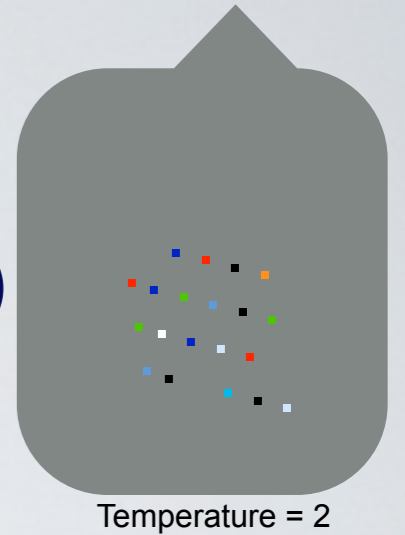

Preassembled
seed structure
(encodes simulated
TAS)

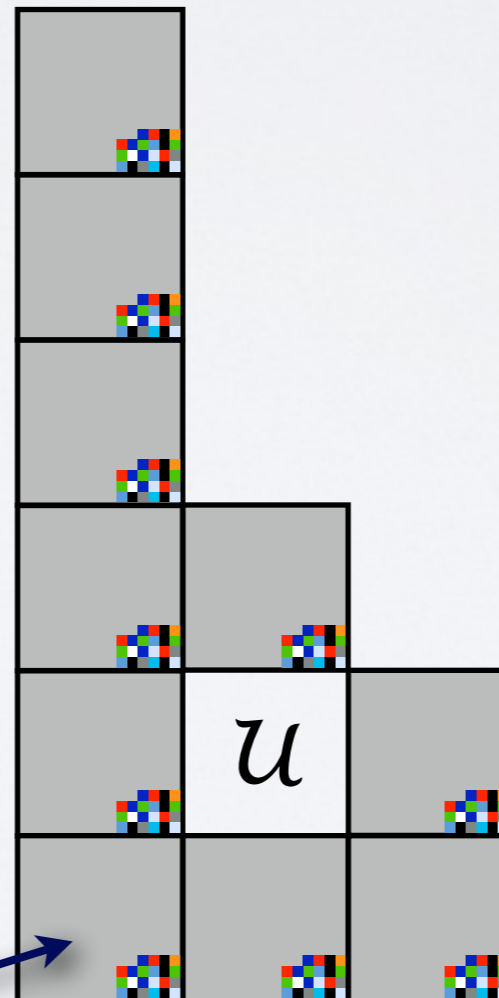

Simulated
tile

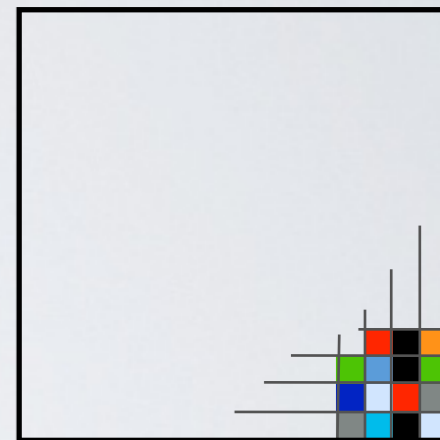
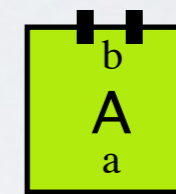

Simulator
supertile

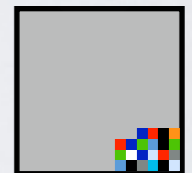

- Green tiles are simulated by supertiles
- For each assembly sequence in the simulated tile system, there is an assembly sequence in the simulator, and vice-versa

Simulation definition

Universal
(simulator)
tile set

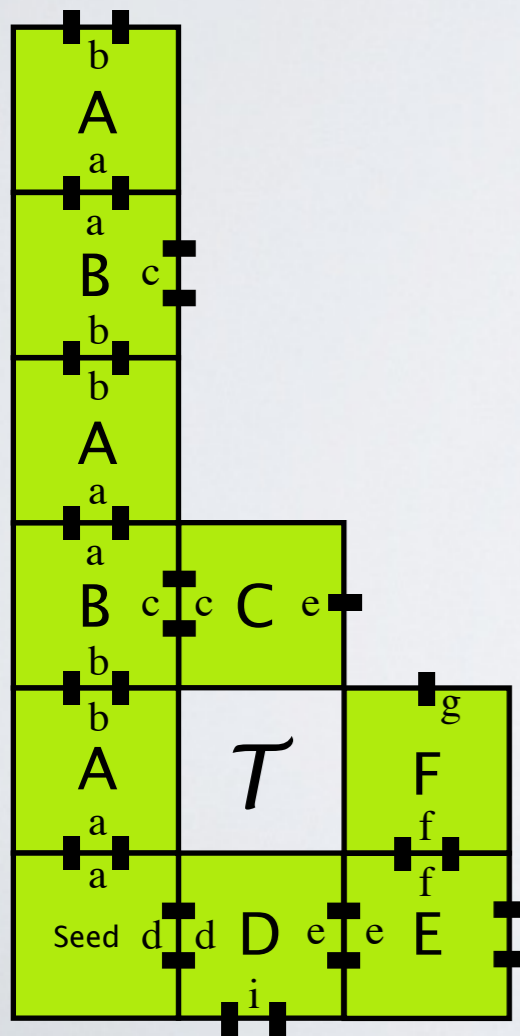
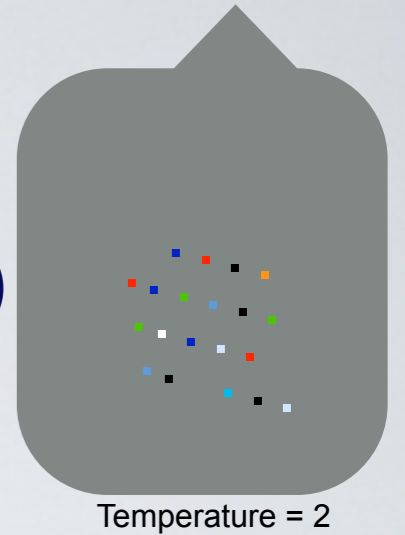

Preassembled
seed structure
(encodes simulated
TAS)

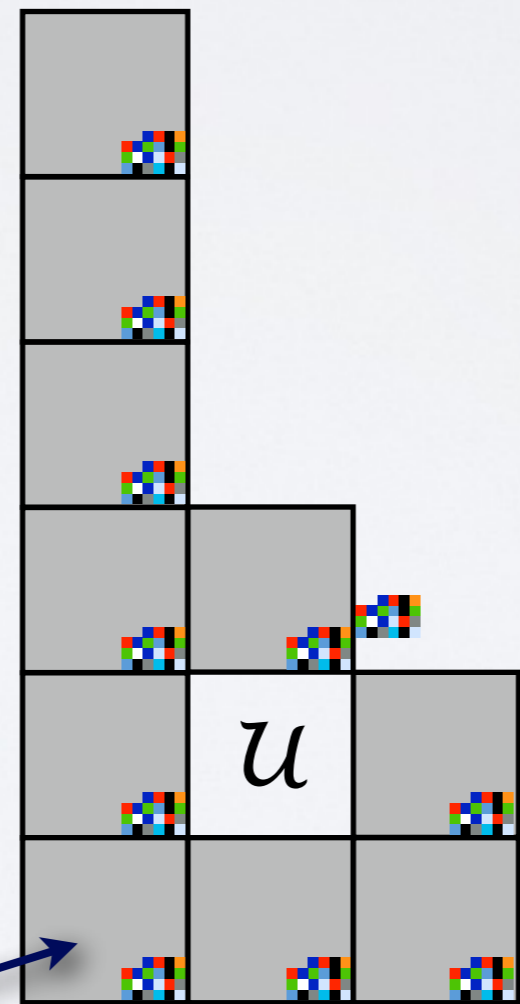

Simulated
tile

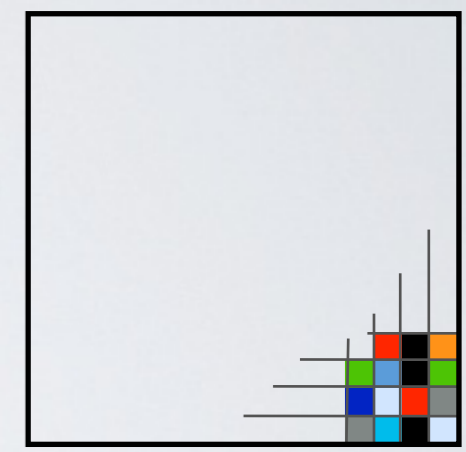
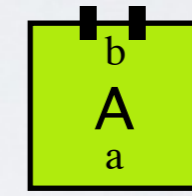

Simulator
supertile

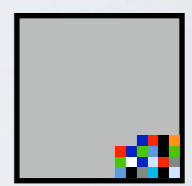

- Green tiles are simulated by supertiles
- For each assembly sequence in the simulated tile system, there is an assembly sequence in the simulator, and vice-versa

Simulation definition

Universal
(simulator)
tile set

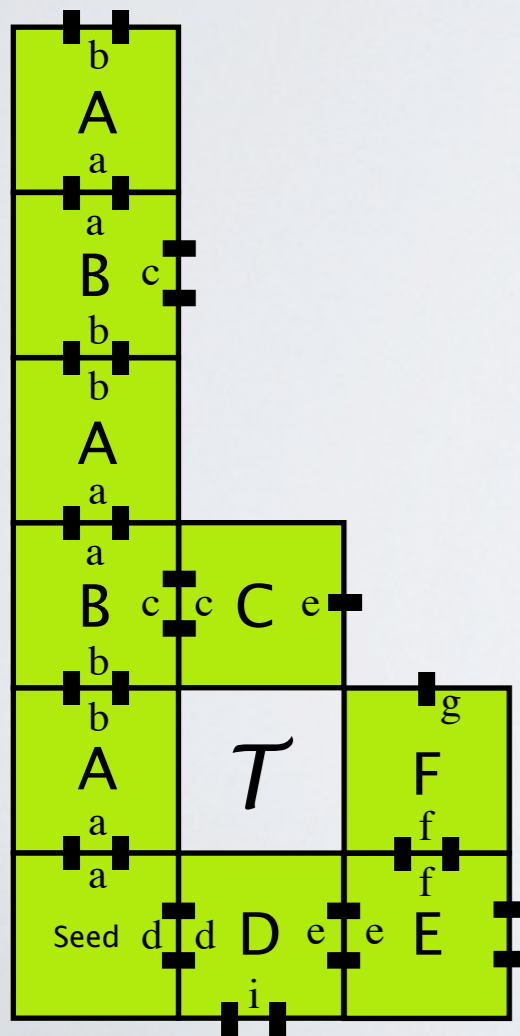
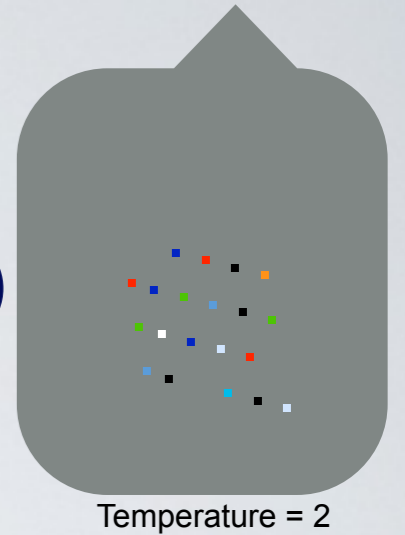

Preassembled
seed structure
(encodes simulated
TAS)

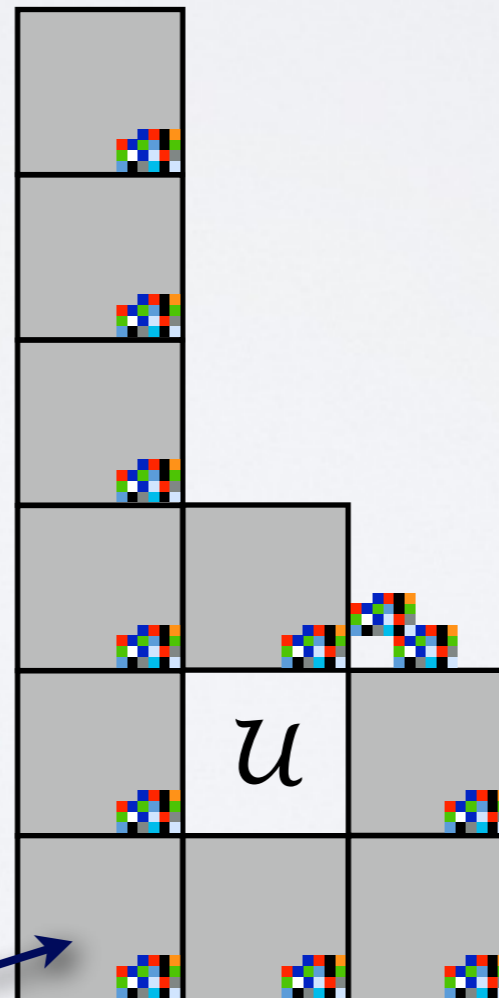

Simulated
tile

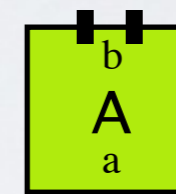

Simulator
supertile

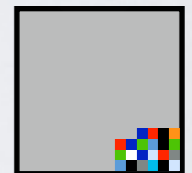

- Green tiles are simulated by supertiles
- For each assembly sequence in the simulated tile system, there is an assembly sequence in the simulator, and vice-versa

Simulation definition

Universal
(simulator)
tile set

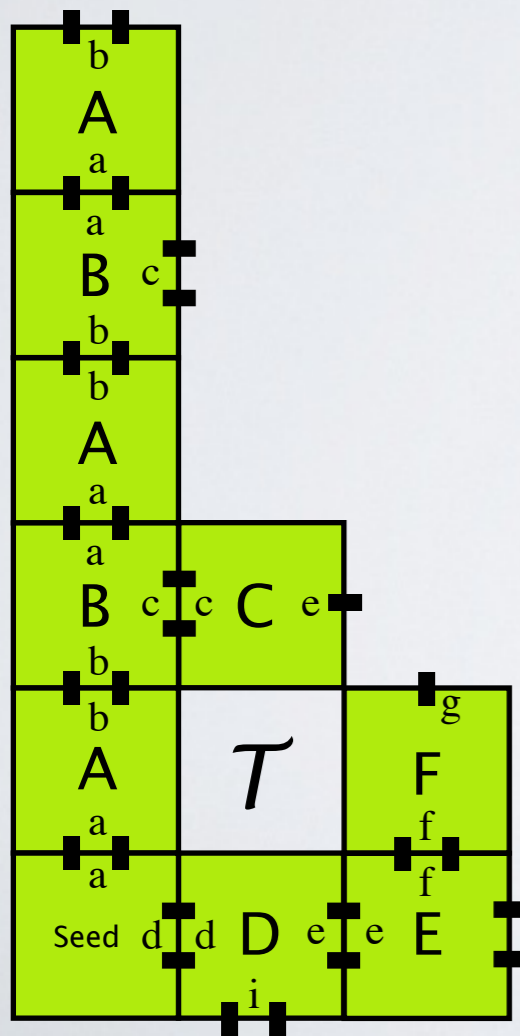
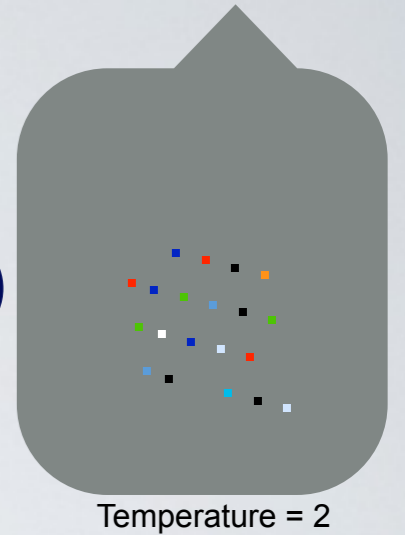

Preassembled
seed structure
(encodes simulated
TAS)

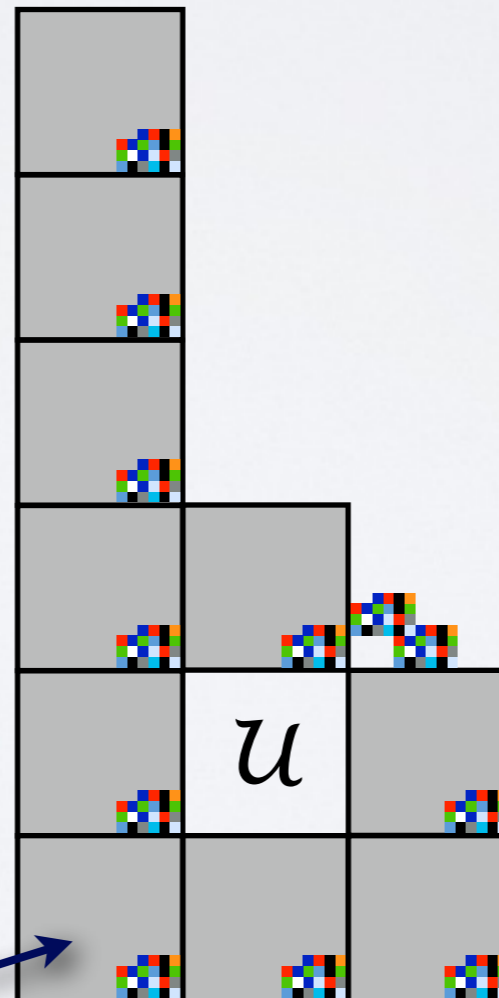

Simulated
tile

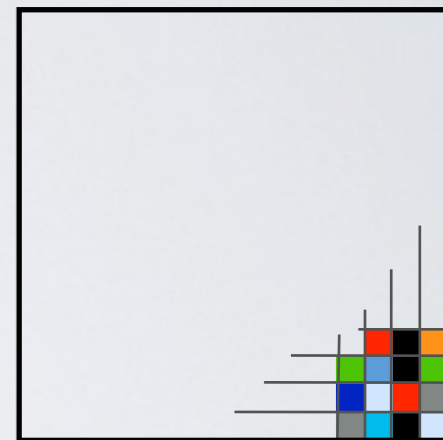
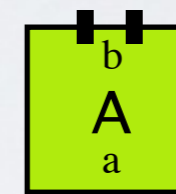

Simulator
supertile

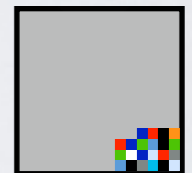

- Green tiles are simulated by supertiles
- For each assembly sequence in the simulated tile system, there is an assembly sequence in the simulator, and vice-versa

etc.

Simulation definition

Ignoring $m \times m$ scaling, production & dynamics are equivalent in the simulated system and simulator

Universal
(simulator)
tile set

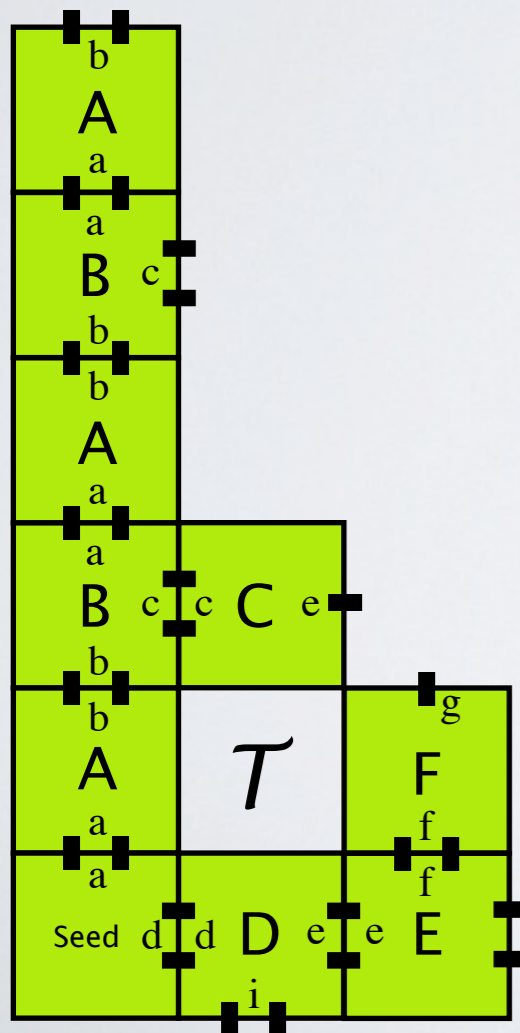
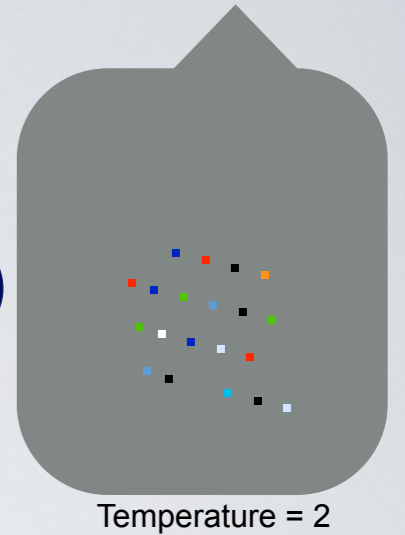

Preassembled
seed structure
(encodes simulated
TAS)

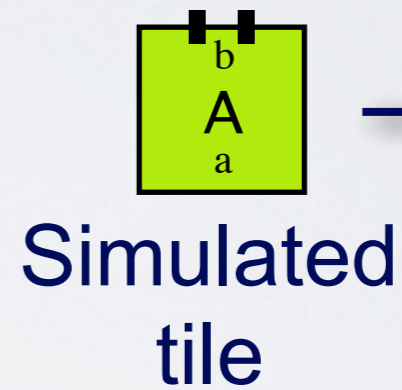
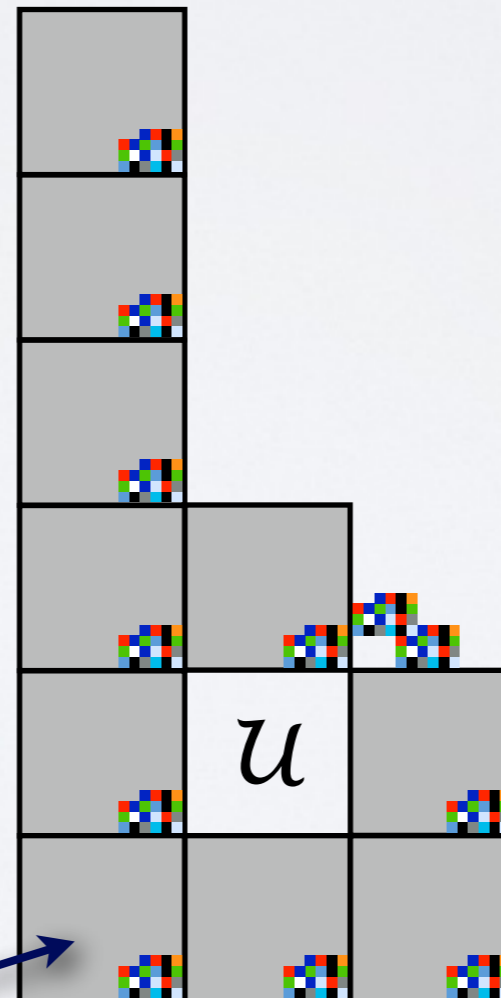

Simulator
supertile

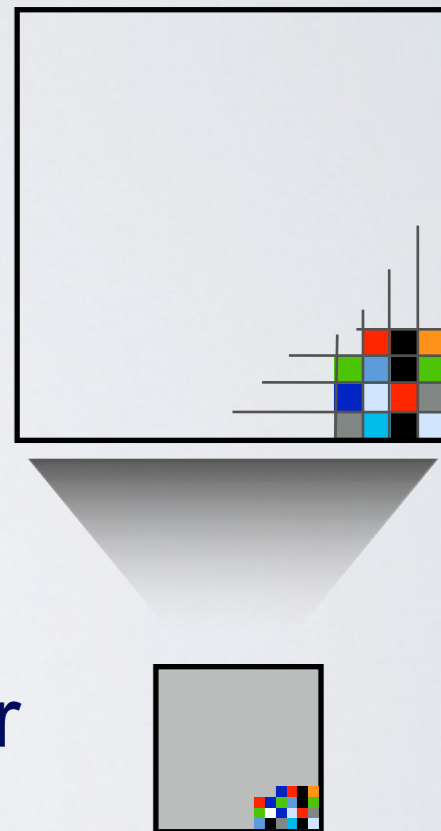

- Green tiles are simulated by supertiles
- For each assembly sequence in the simulated tile system, there is an assembly sequence in the simulator, and vice-versa

etc.

Simulation definition

Universal
(simulator)
tile set

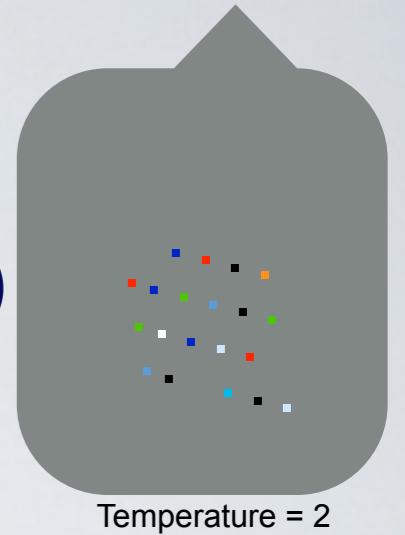

Simulated
tile

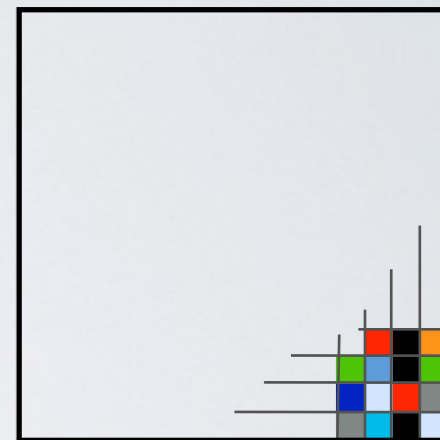
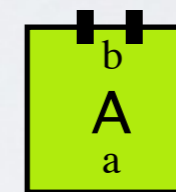

Simulator
supertile

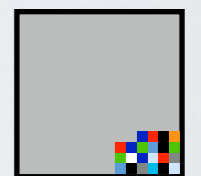

\mathcal{T}

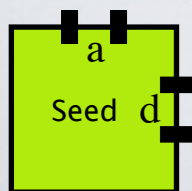

Preassembled
seed structure
(encodes simulated
TAS)

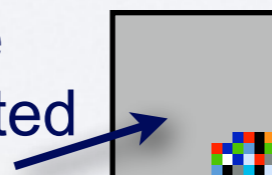

\mathcal{U}

- Green tiles are simulated by supertiles
- For each assembly sequence in the simulated tile system, there is an assembly sequence in the simulator, and vice-versa

Simulation definition

Universal
(simulator)
tile set

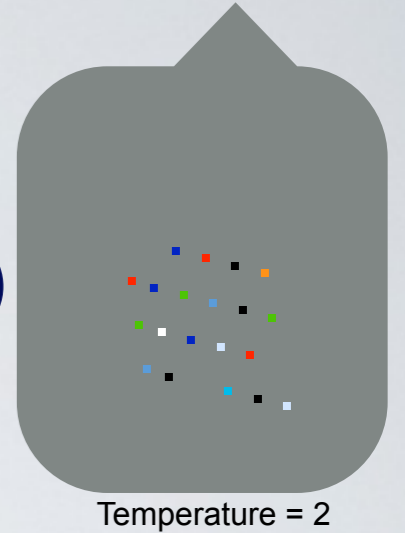

Simulated
tile

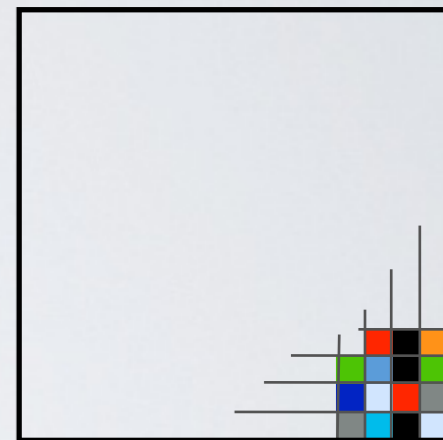
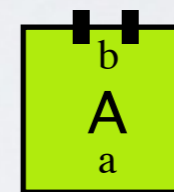

Simulator
supertile

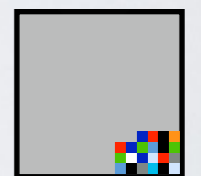

Preassembled
seed structure
(encodes simulated
TAS)

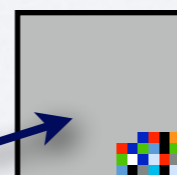

\mathcal{U}

\mathcal{T}

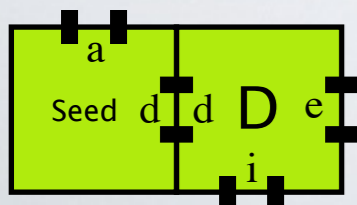

- Green tiles are simulated by supertiles
- For each assembly sequence in the simulated tile system, there is an assembly sequence in the simulator, and vice-versa

Simulation definition

Universal
(simulator)
tile set

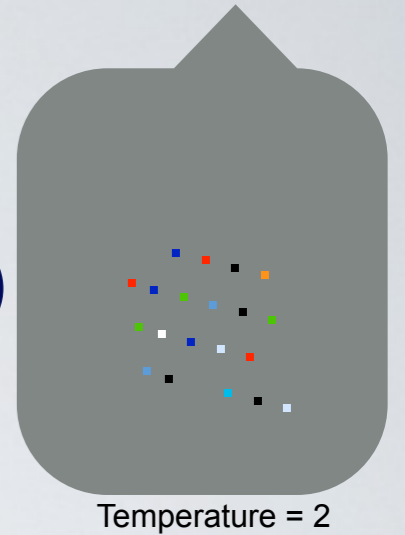

Simulated
tile

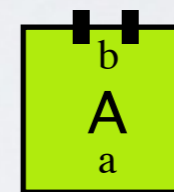

Simulator
supertile

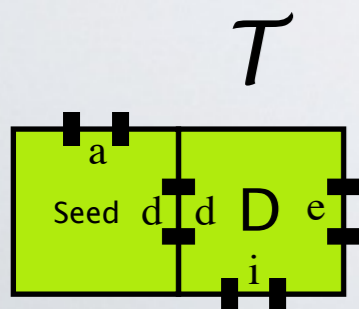
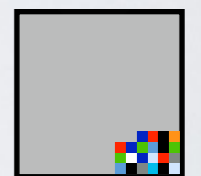

Preassembled
seed structure
(encodes simulated
TAS)



- Green tiles are simulated by supertiles
- For each assembly sequence in the simulated tile system, there is an assembly sequence in the simulator, and vice-versa

Simulation definition

Universal
(simulator)
tile set

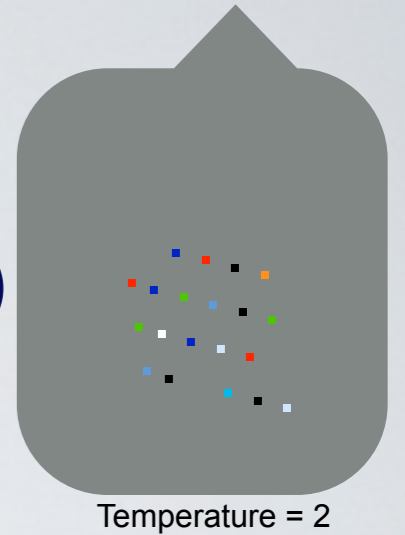

Simulated
tile

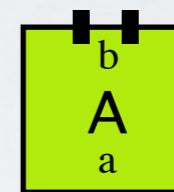

Simulator
supertile

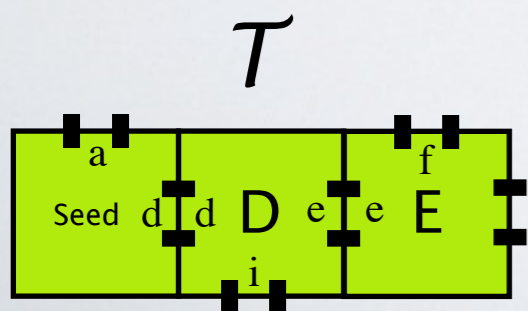
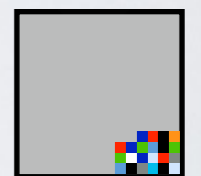

Preassembled
seed structure
(encodes simulated
TAS)



- Green tiles are simulated by supertiles
- For each assembly sequence in the simulated tile system, there is an assembly sequence in the simulator, and vice-versa

Simulation definition

Universal
(simulator)
tile set

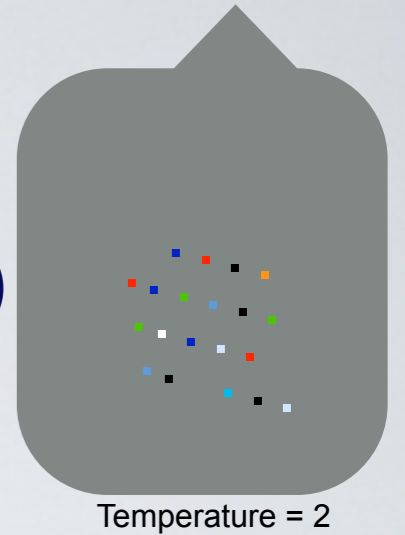

Simulated
tile

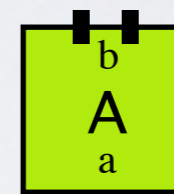

Simulator
supertile

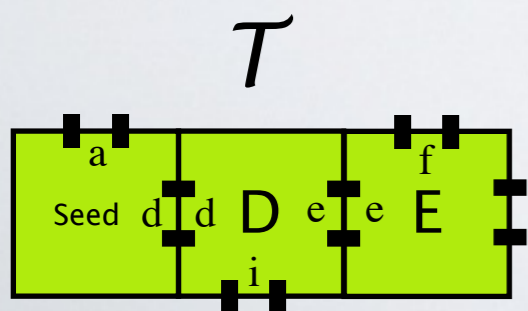
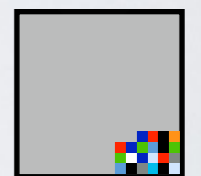

Preassembled
seed structure
(encodes simulated
TAS)

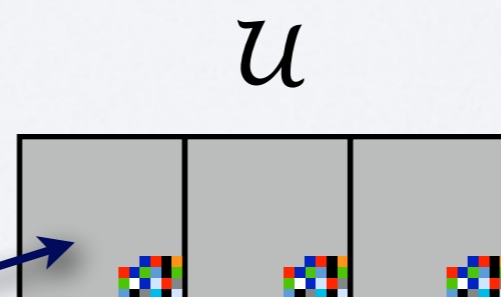

- Green tiles are simulated by supertiles
- For each assembly sequence in the simulated tile system, there is an assembly sequence in the simulator, and vice-versa

Simulation definition

Universal
(simulator)
tile set

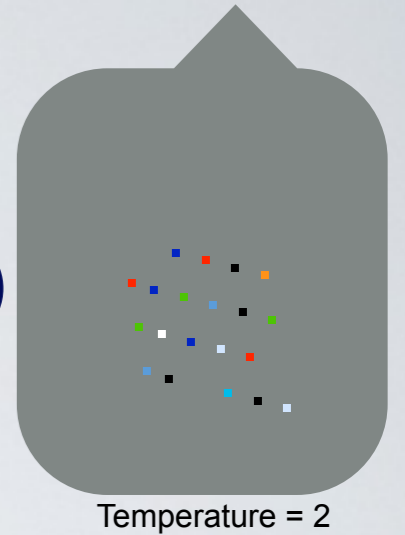

Simulated
tile

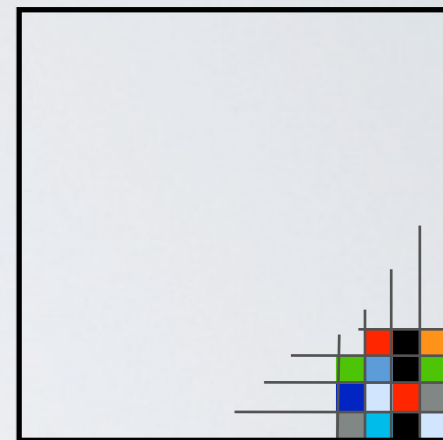
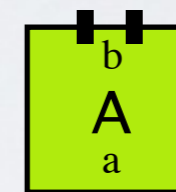

Simulator
supertile

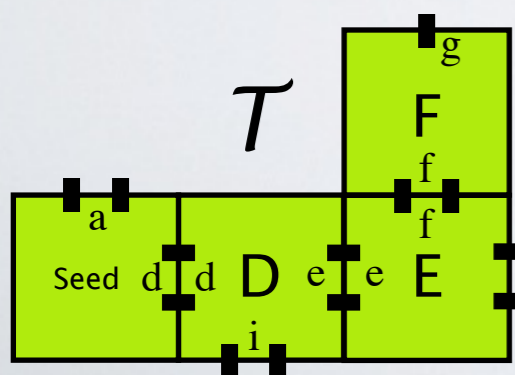
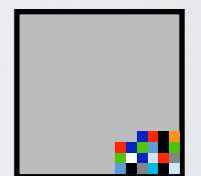

Preassembled
seed structure
(encodes simulated
TAS)

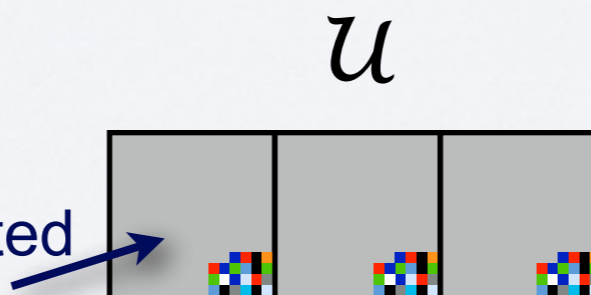

- Green tiles are simulated by supertiles
- For each assembly sequence in the simulated tile system, there is an assembly sequence in the simulator, and vice-versa

Simulation definition

Universal
(simulator)
tile set

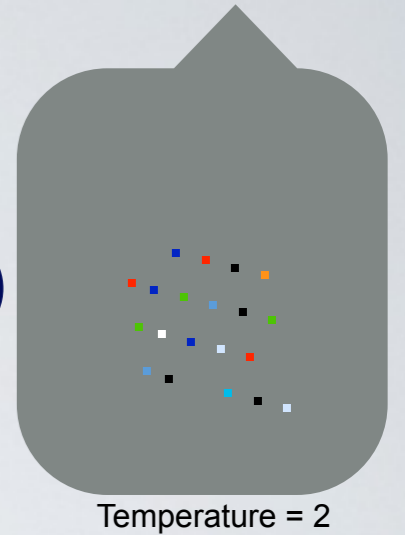

Simulated
tile

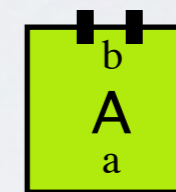

Simulator
supertile

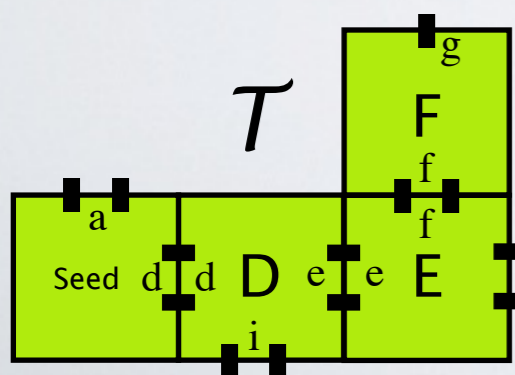
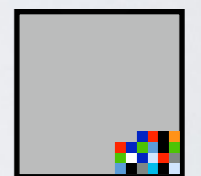

Preassembled
seed structure
(encodes simulated
TAS)

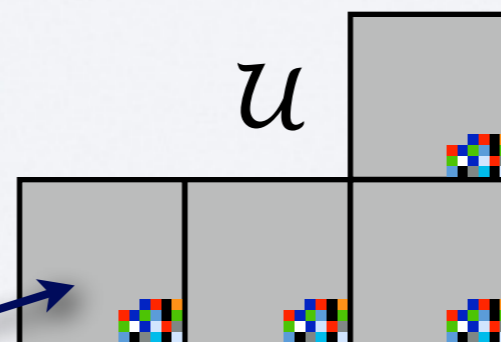

- Green tiles are simulated by supertiles
- For each assembly sequence in the simulated tile system, there is an assembly sequence in the simulator, and vice-versa

Simulation definition

Universal
(simulator)
tile set

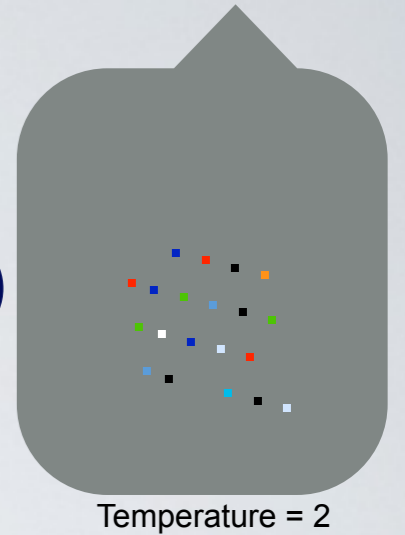

Simulated
tile

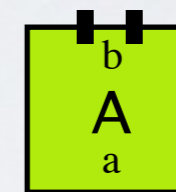

Simulator
supertile

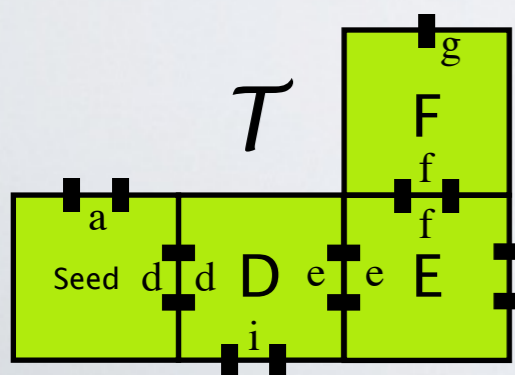
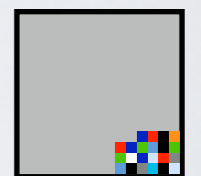

Preassembled
seed structure
(encodes simulated
TAS)

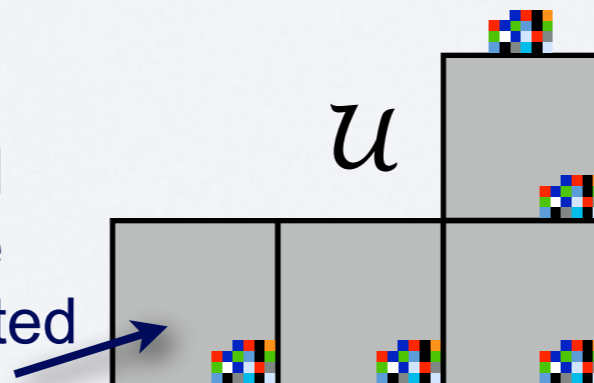

- Green tiles are simulated by supertiles
- For each assembly sequence in the simulated tile system, there is an assembly sequence in the simulator, and vice-versa

Simulation definition

Universal
(simulator)
tile set

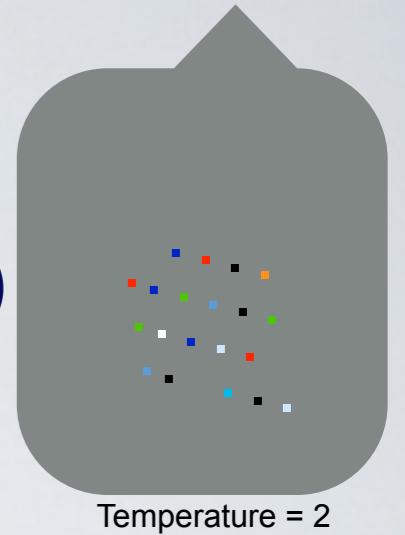

Simulated
tile

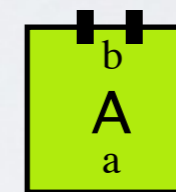

Simulator
supertile

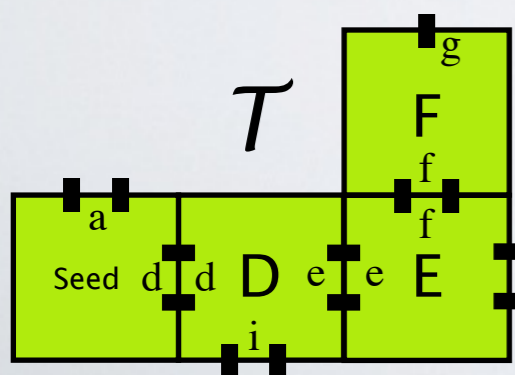
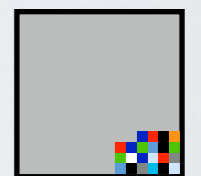

Preassembled
seed structure
(encodes simulated
TAS)

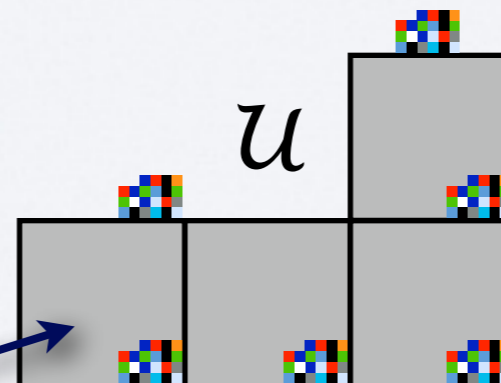

- Green tiles are simulated by supertiles
- For each assembly sequence in the simulated tile system, there is an assembly sequence in the simulator, and vice-versa

Simulation definition

Universal
(simulator)
tile set

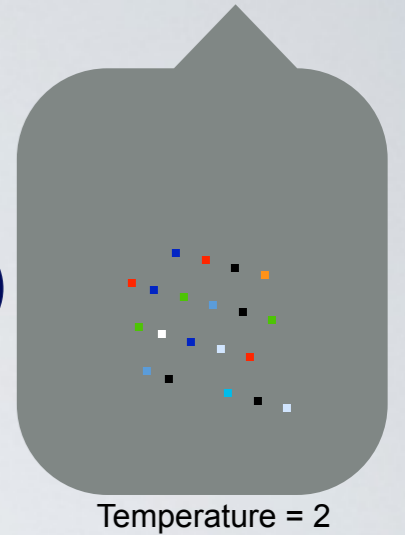

Simulated
tile

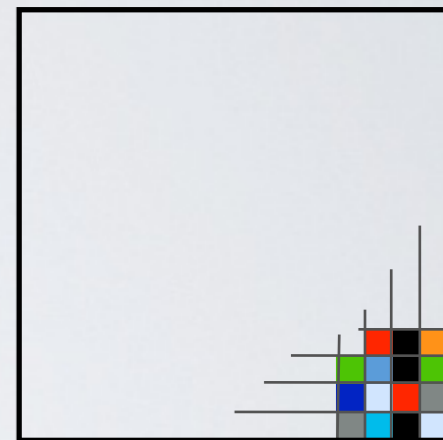
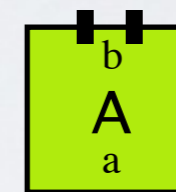

Simulator
supertile

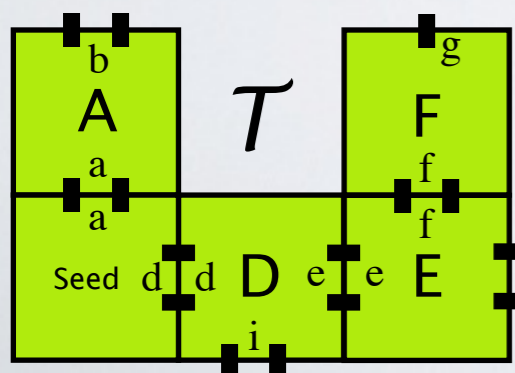
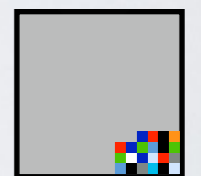

Preassembled
seed structure
(encodes simulated
TAS)

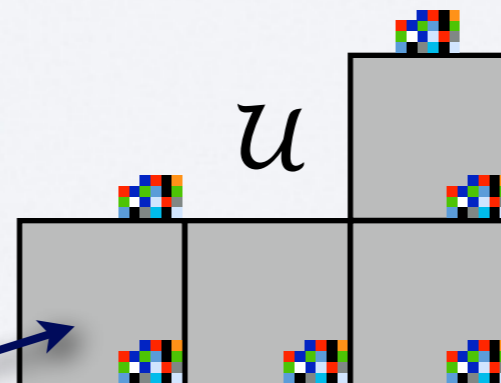

- Green tiles are simulated by supertiles
- For each assembly sequence in the simulated tile system, there is an assembly sequence in the simulator, and vice-versa

Simulation definition

Universal
(simulator)
tile set

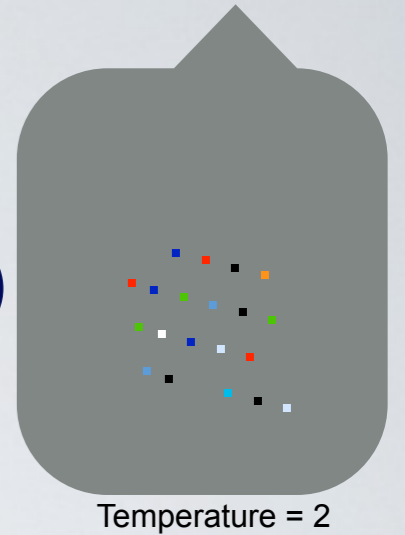

Simulated
tile

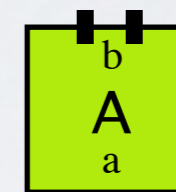

Simulator
supertile

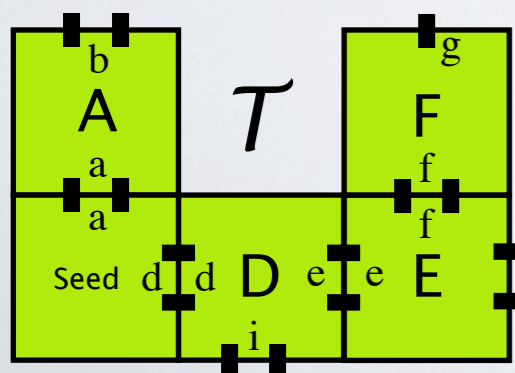
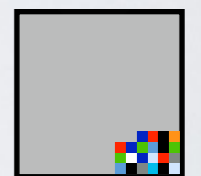

Preassembled
seed structure
(encodes simulated
TAS)

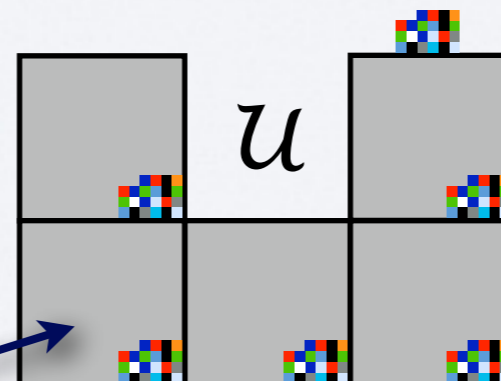

- Green tiles are simulated by supertiles
- For each assembly sequence in the simulated tile system, there is an assembly sequence in the simulator, and vice-versa

Simulation definition

Universal
(simulator)
tile set

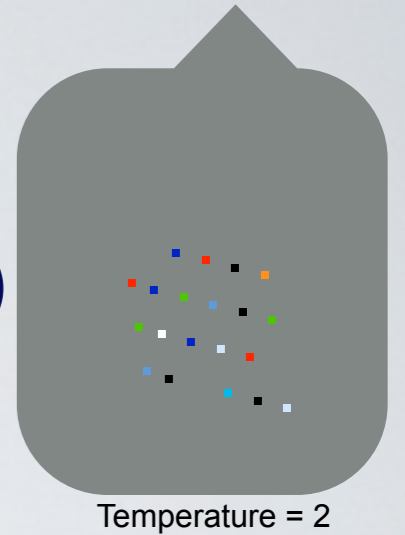

Simulated
tile

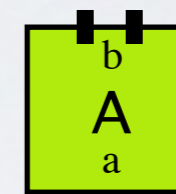

Simulator
supertile

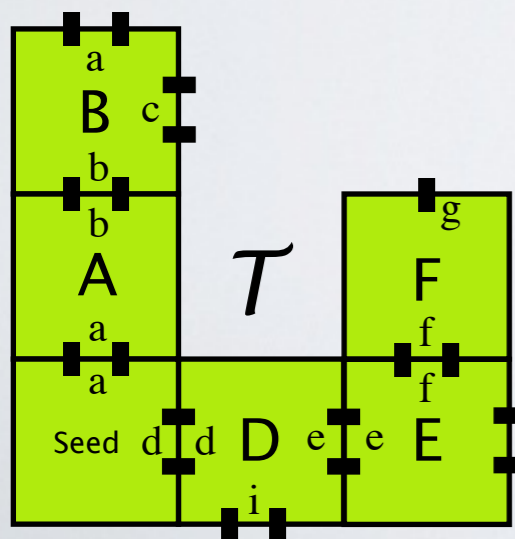
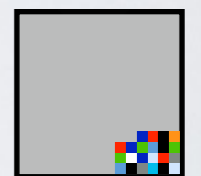

Preassembled
seed structure
(encodes simulated
TAS)

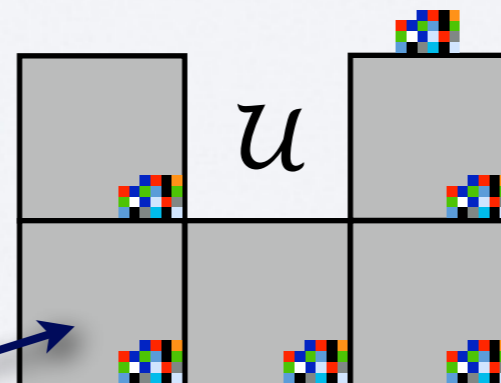

- Green tiles are simulated by supertiles
- For each assembly sequence in the simulated tile system, there is an assembly sequence in the simulator, and vice-versa

Simulation definition

Universal
(simulator)
tile set

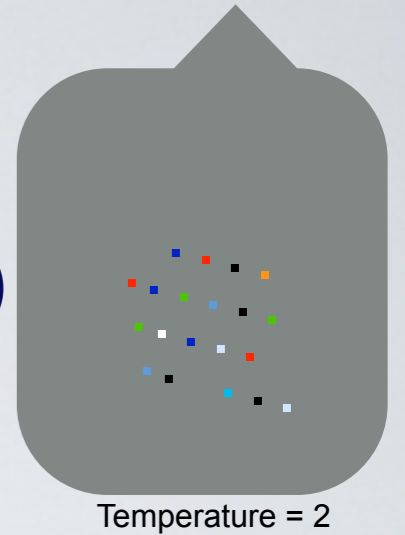

Simulated
tile

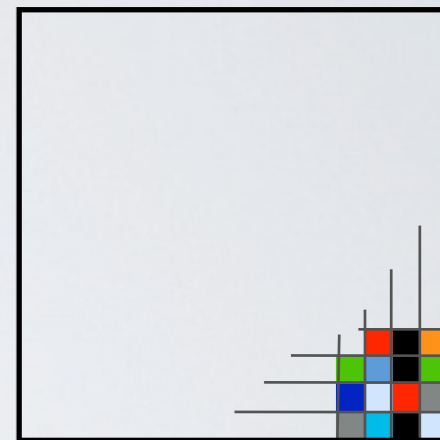
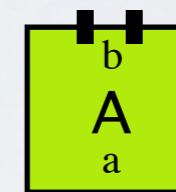

Simulator
supertile

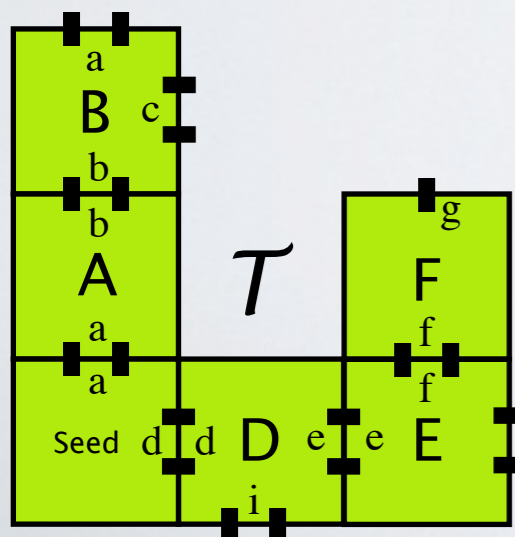
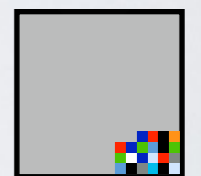

Preassembled
seed structure
(encodes simulated
TAS)

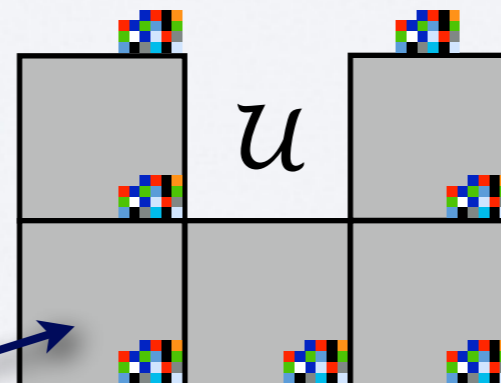

- Green tiles are simulated by supertiles
- For each assembly sequence in the simulated tile system, there is an assembly sequence in the simulator, and vice-versa

Simulation definition

Universal
(simulator)
tile set

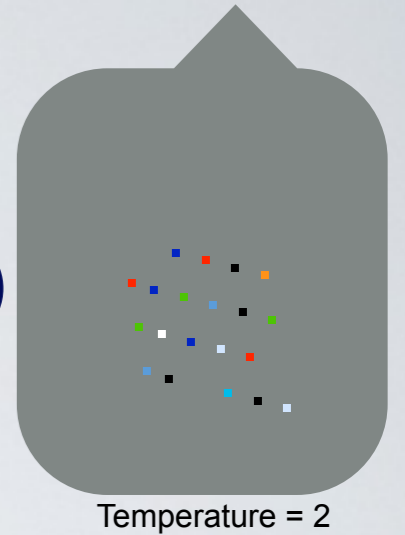

Simulated
tile

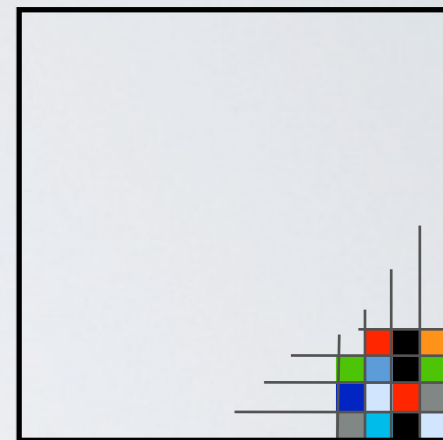
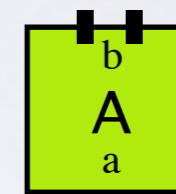

Simulator
supertile

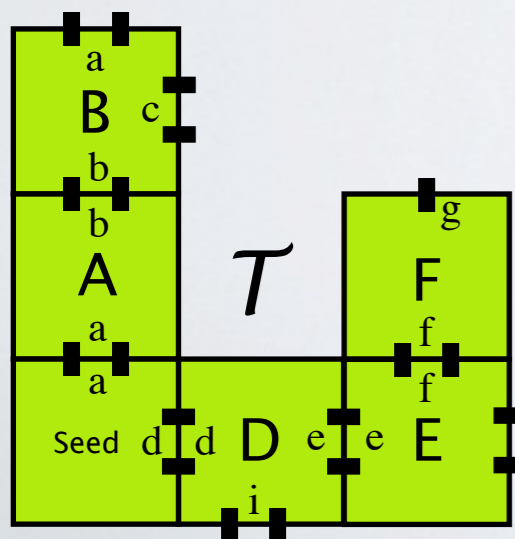
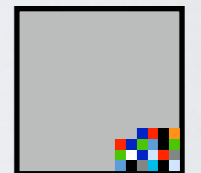

Preassembled
seed structure
(encodes simulated
TAS)

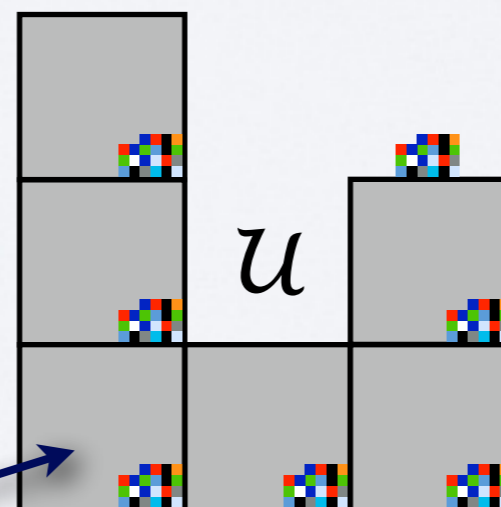

- Green tiles are simulated by supertiles
- For each assembly sequence in the simulated tile system, there is an assembly sequence in the simulator, and vice-versa

Simulation definition

Universal
(simulator)
tile set

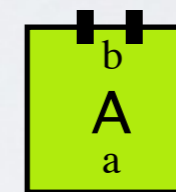
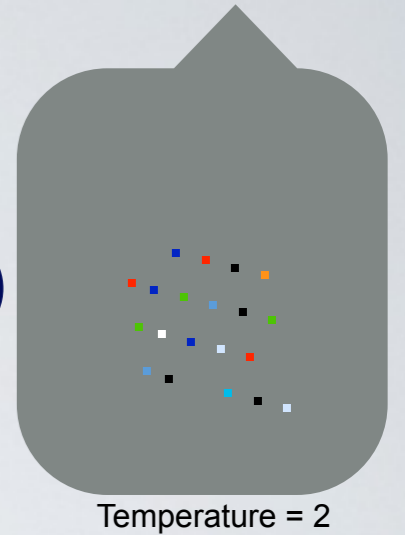

Simulated
tile

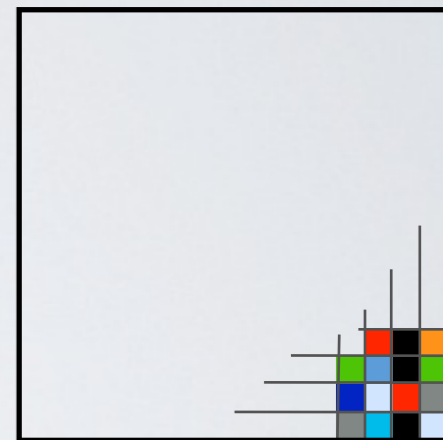

Simulator
supertile

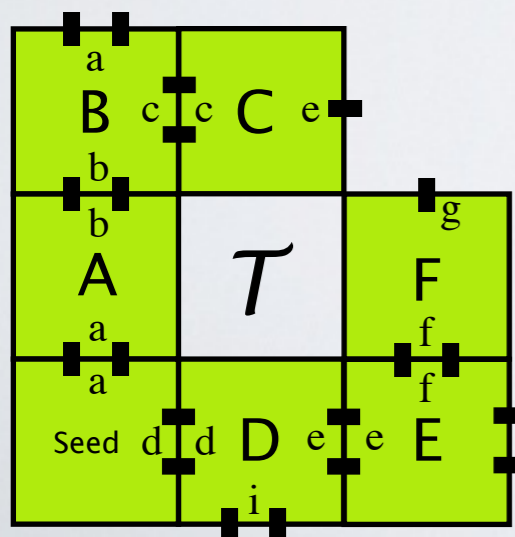
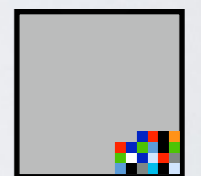

Preassembled
seed structure
(encodes simulated
TAS)

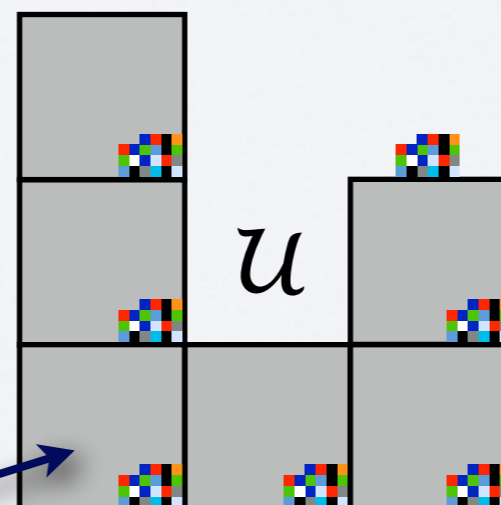

- Green tiles are simulated by supertiles
- For each assembly sequence in the simulated tile system, there is an assembly sequence in the simulator, and vice-versa

Simulation definition

Universal
(simulator)
tile set

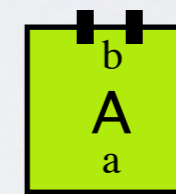
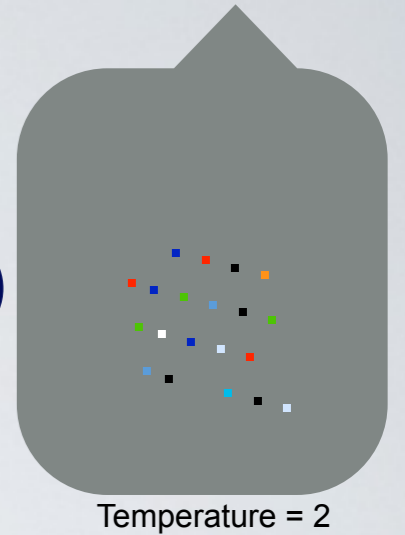

Simulated
tile

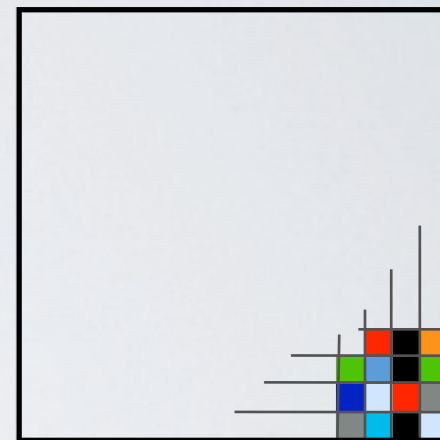

Simulator
supertile

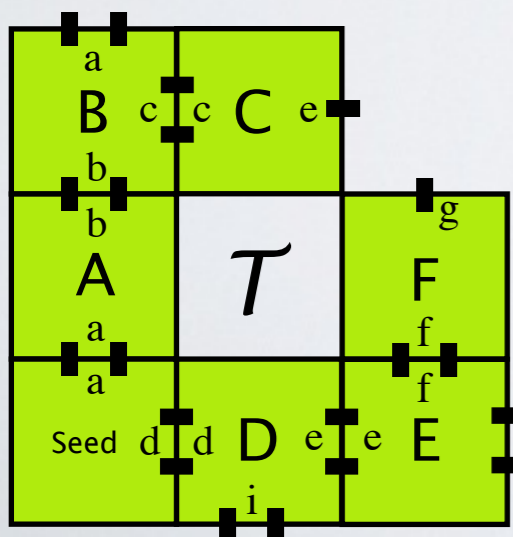
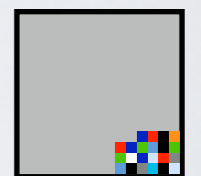

Preassembled
seed structure
(encodes simulated
TAS)

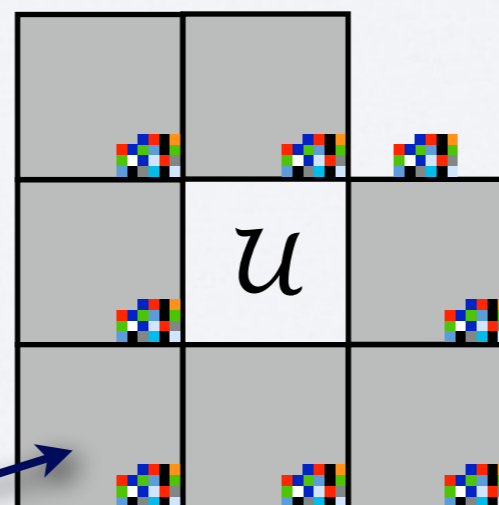

- Green tiles are simulated by supertiles
- For each assembly sequence in the simulated tile system, there is an assembly sequence in the simulator, and vice-versa

Simulation definition

Universal
(simulator)
tile set

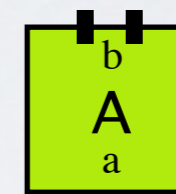
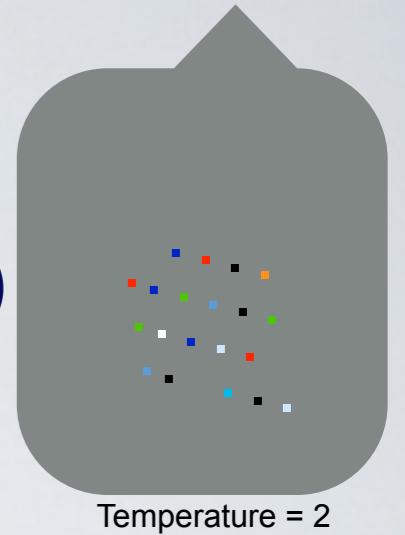

Simulated
tile



Simulator
supertile

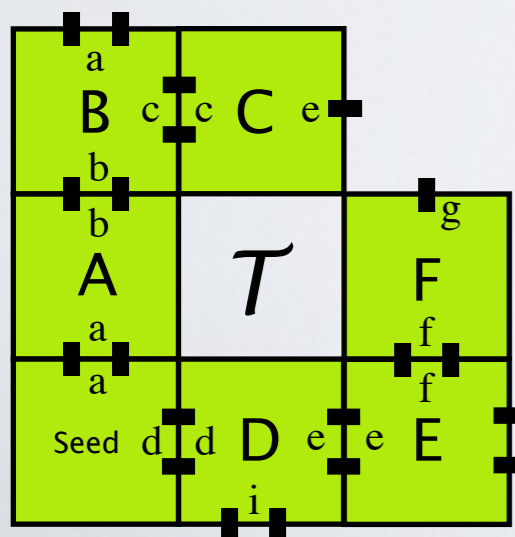
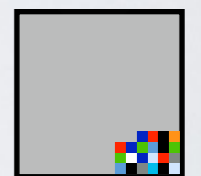

Preassembled
seed structure
(encodes simulated
TAS)

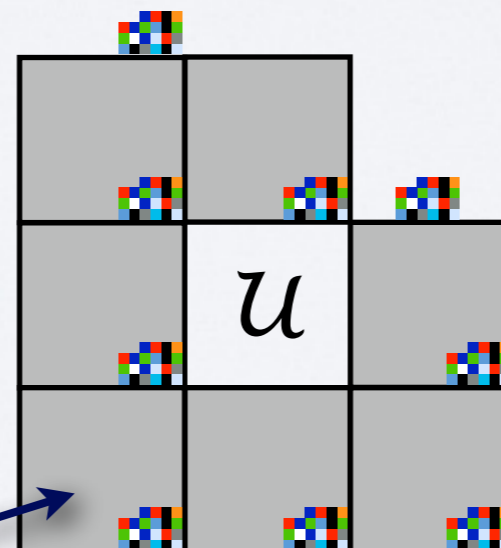

- Green tiles are simulated by supertiles
- For each assembly sequence in the simulated tile system, there is an assembly sequence in the simulator, and vice-versa

Simulation definition

Universal
(simulator)
tile set

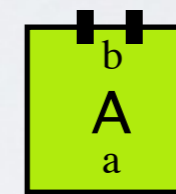
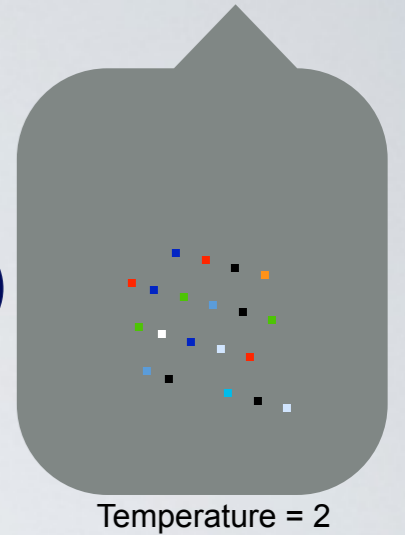

Simulated
tile

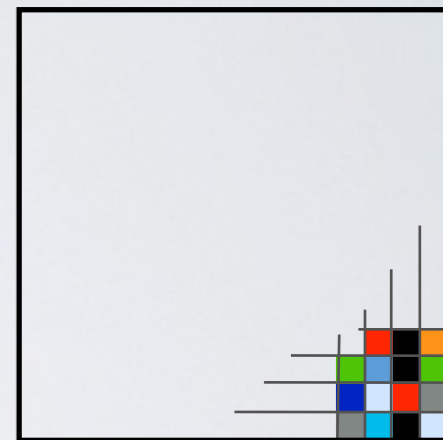

Simulator
supertile

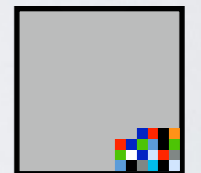

- Green tiles are simulated by supertiles
- For each assembly sequence in the simulated tile system, there is an assembly sequence in the simulator, and vice-versa

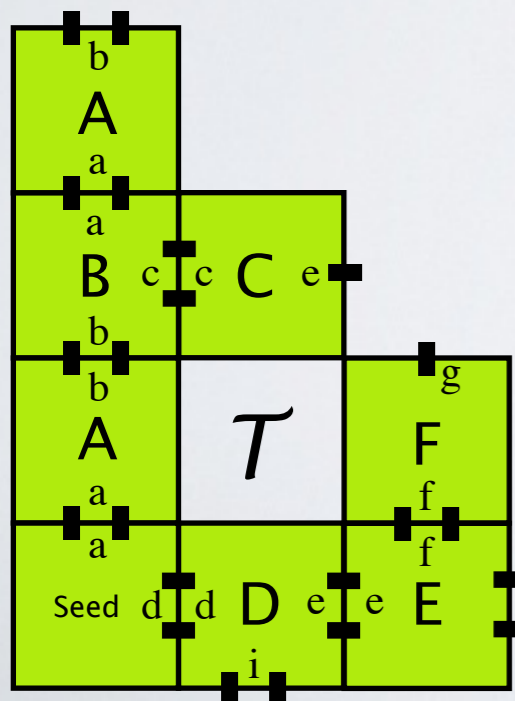

Preassembled
seed structure
(encodes simulated
TAS)

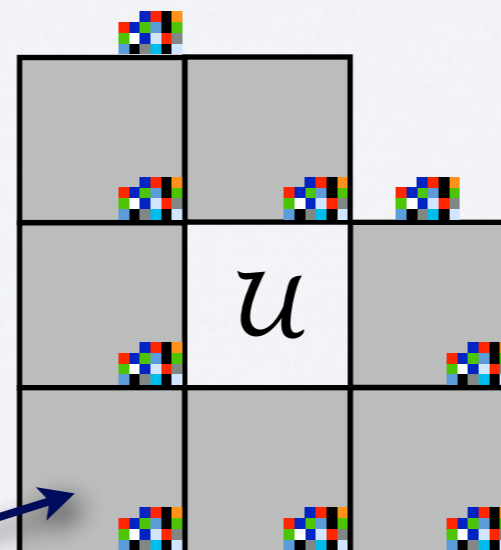

Simulation definition

Universal
(simulator)
tile set

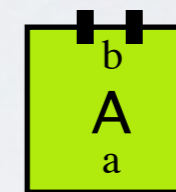
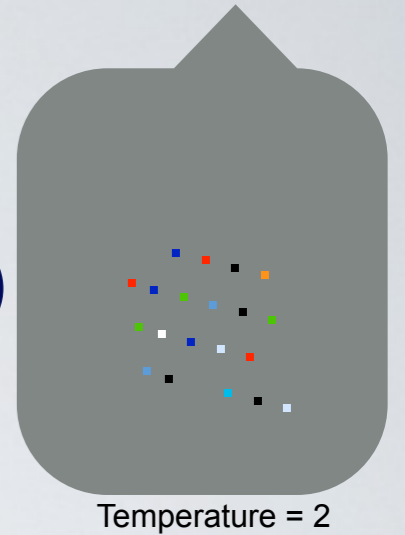

Simulated
tile



Simulator
supertile

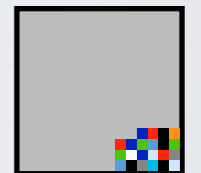

- Green tiles are simulated by supertiles
- For each assembly sequence in the simulated tile system, there is an assembly sequence in the simulator, and vice-versa

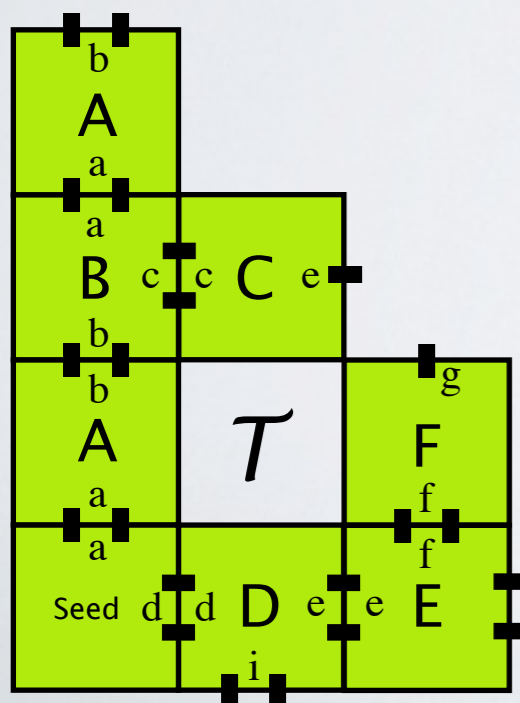

Preassembled
seed structure
(encodes simulated
TAS)

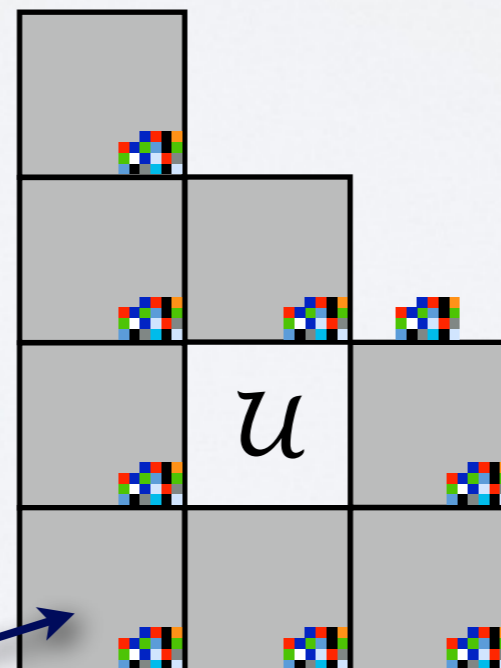

Simulation definition

Universal
(simulator)
tile set

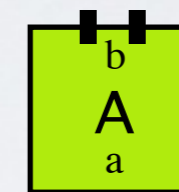
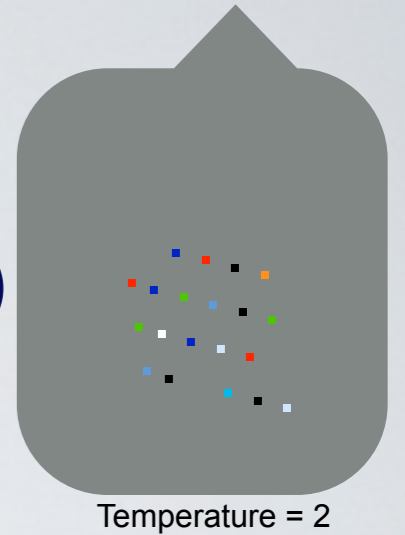

Simulated
tile



Simulator
supertile

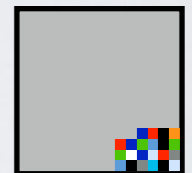

- Green tiles are simulated by supertiles
- For each assembly sequence in the simulated tile system, there is an assembly sequence in the simulator, and vice-versa

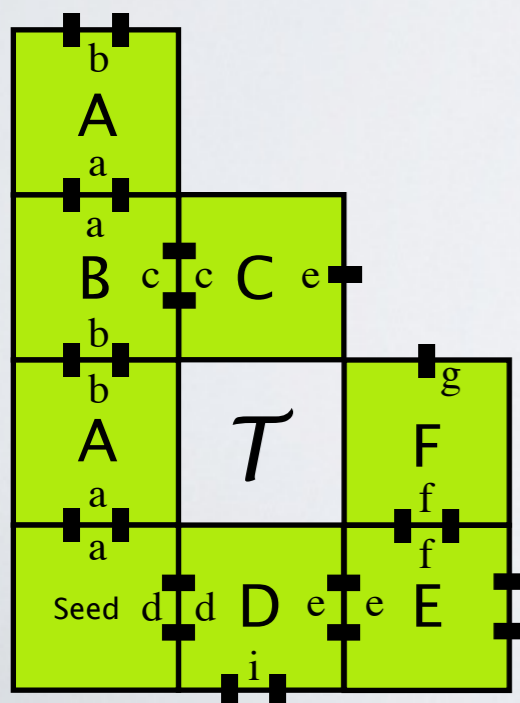

Preassembled
seed structure
(encodes simulated
TAS)

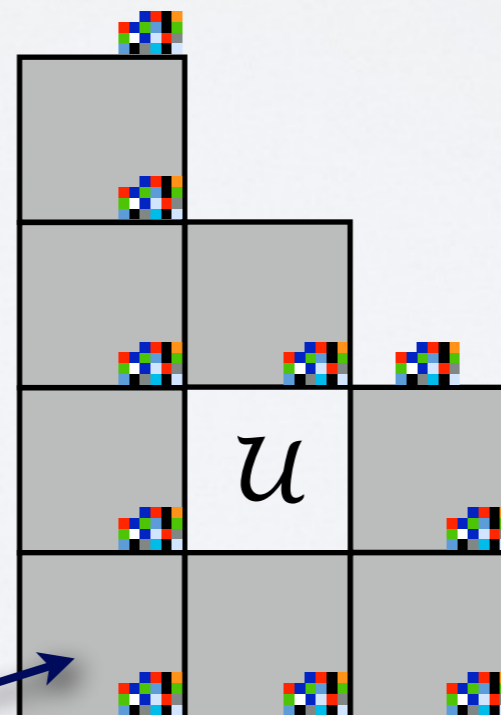

Simulation definition

Universal
(simulator)
tile set

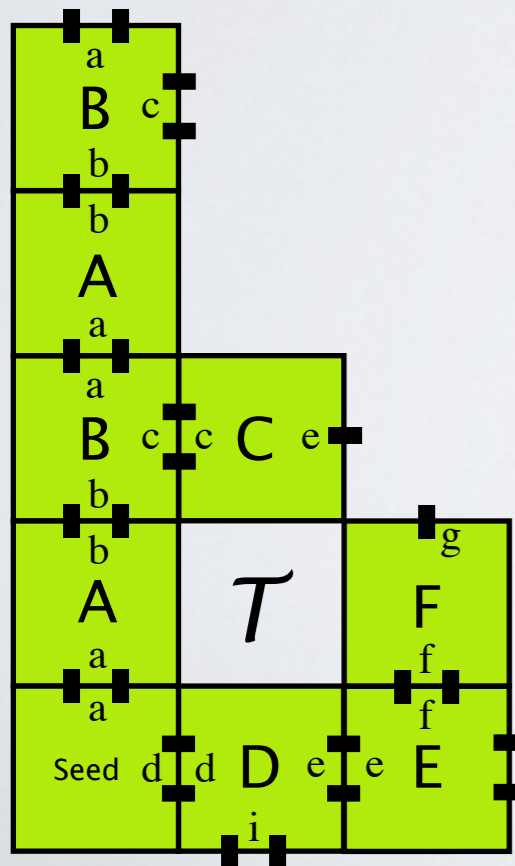
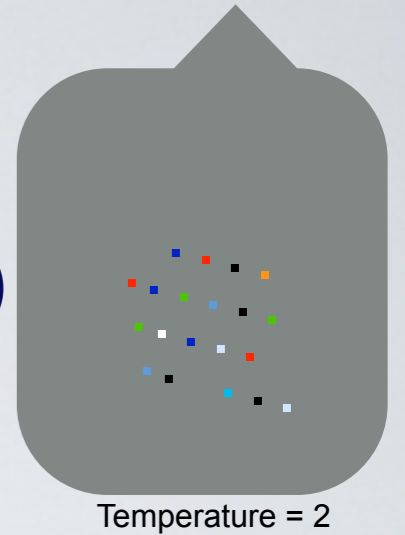

Preassembled
seed structure
(encodes simulated
TAS)

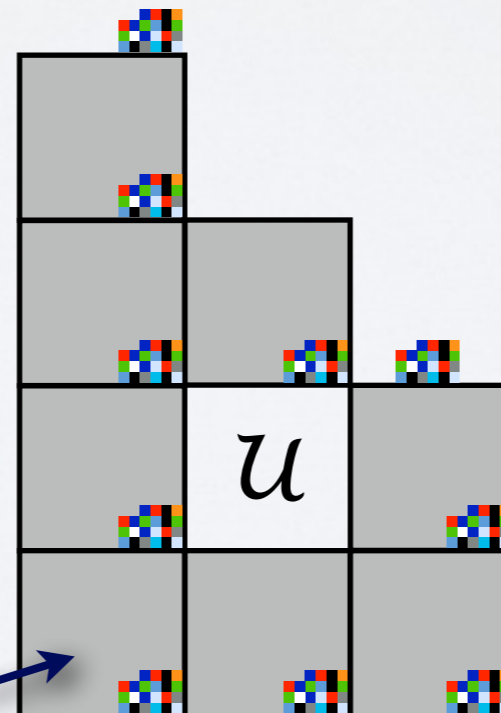

Simulated
tile

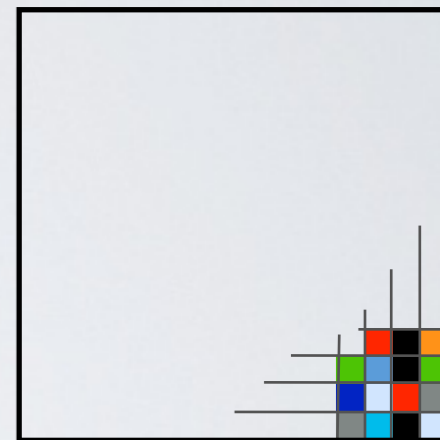
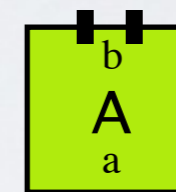

Simulator
supertile

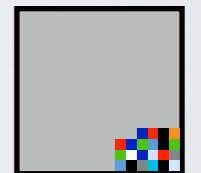

- Green tiles are simulated by supertiles
- For each assembly sequence in the simulated tile system, there is an assembly sequence in the simulator, and vice-versa

Simulation definition

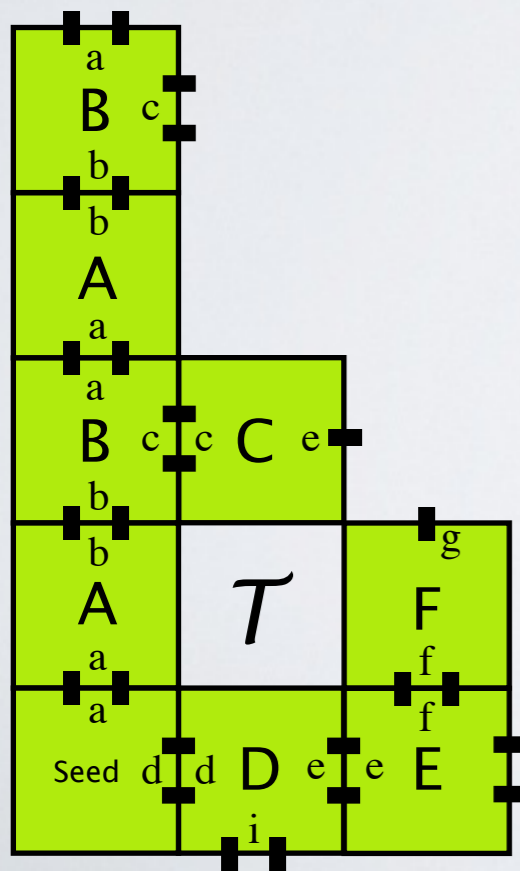

Preassembled seed structure (encodes simulated TAS)

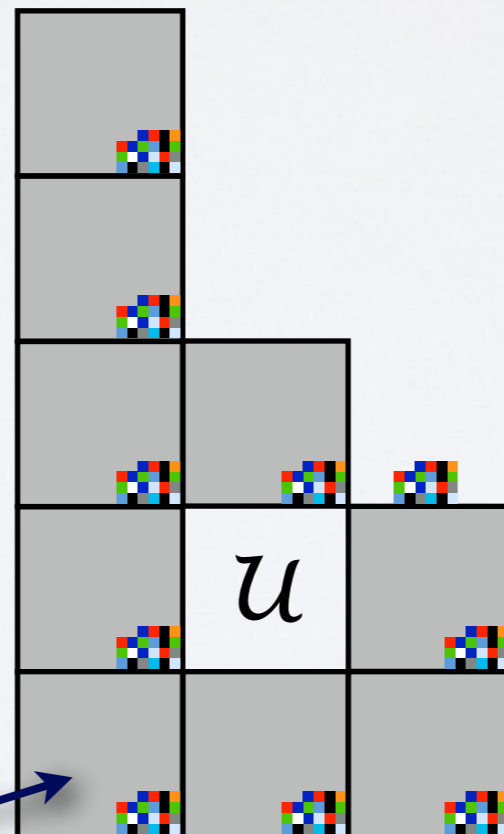

Universal (simulator) tile set

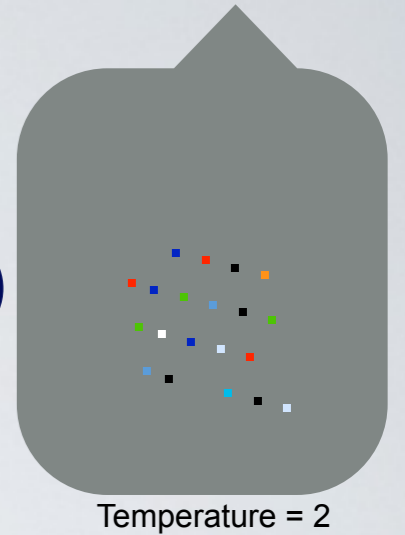

Simulated tile

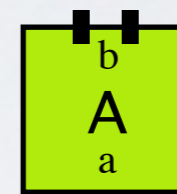

Simulator supertile

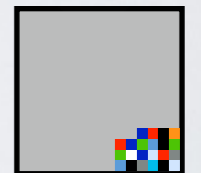

- Green tiles are simulated by supertiles
- For each assembly sequence in the simulated tile system, there is an assembly sequence in the simulator, and vice-versa

Simulation definition

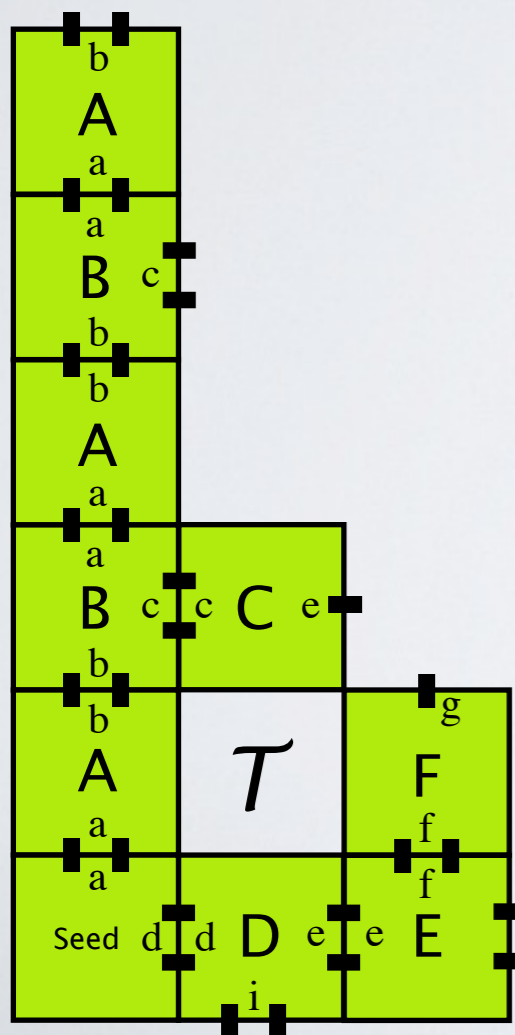

Preassembled seed structure (encodes simulated TAS)

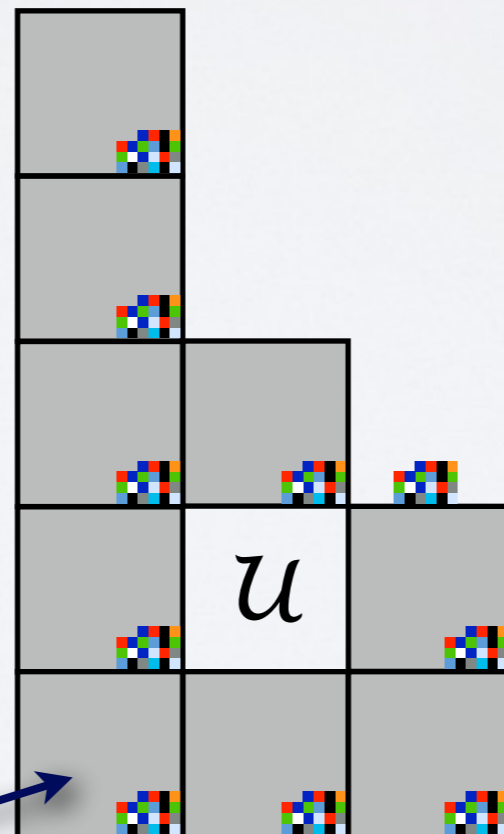

Universal (simulator) tile set

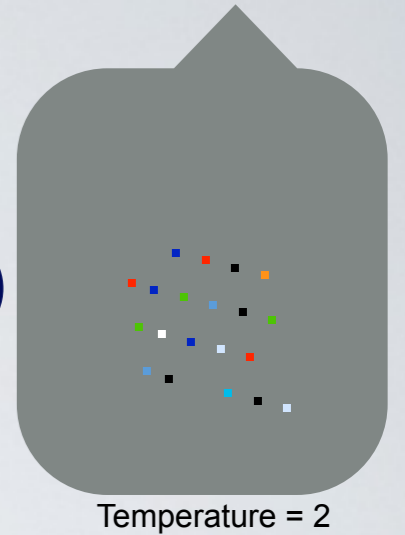

Simulated tile

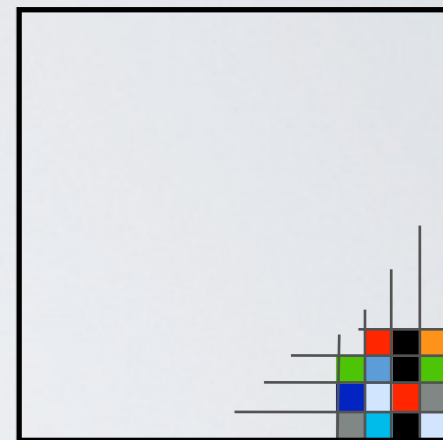
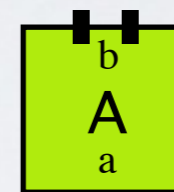

Simulator supertile

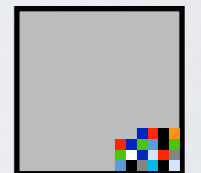

- Green tiles are simulated by supertiles
- For each assembly sequence in the simulated tile system, there is an assembly sequence in the simulator, and vice-versa

Simulation definition

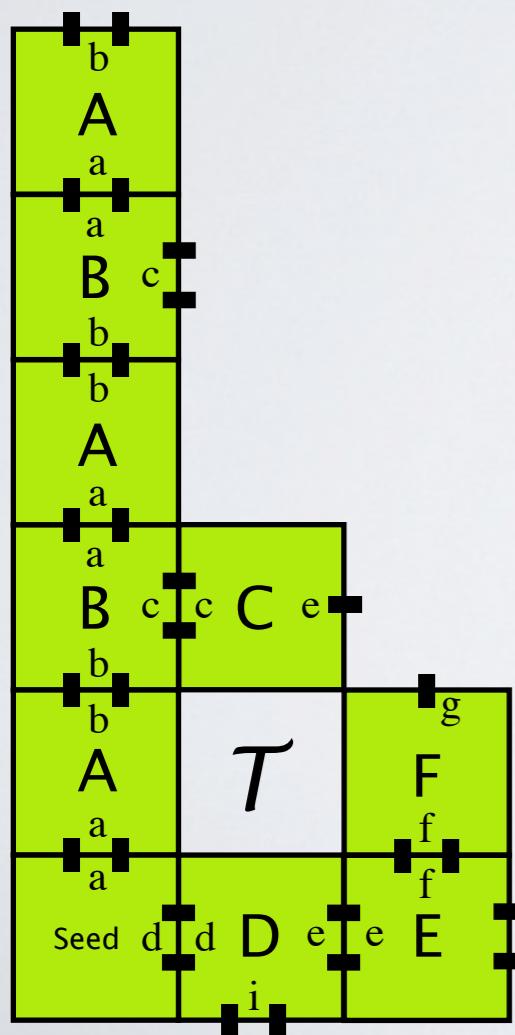

Preassembled seed structure (encodes simulated TAS)

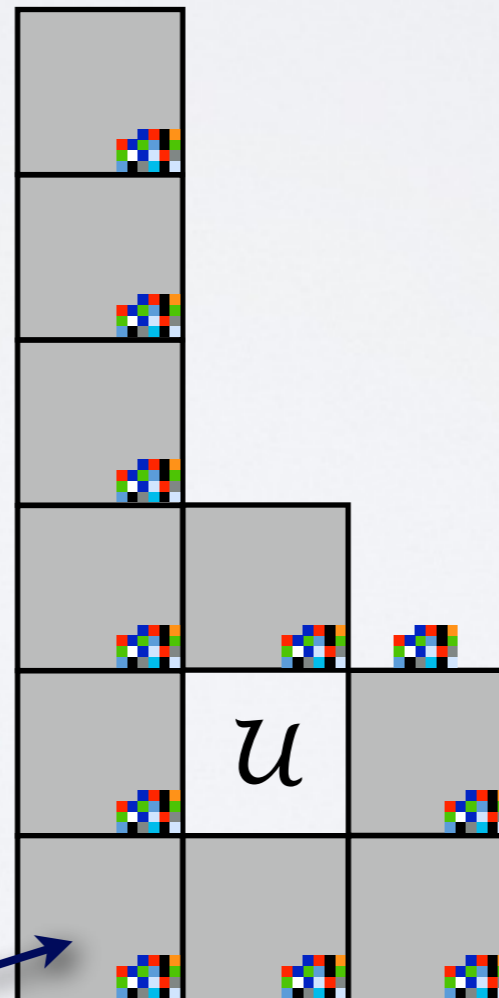

Universal (simulator) tile set

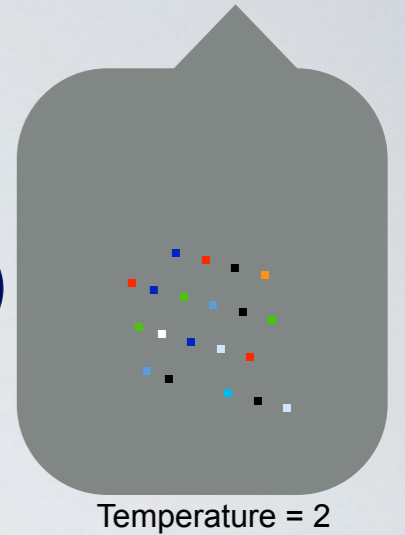

Simulated tile

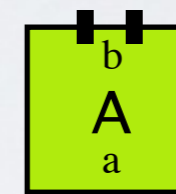

Simulator supertile

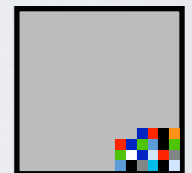

- Green tiles are simulated by supertiles
- For each assembly sequence in the simulated tile system, there is an assembly sequence in the simulator, and vice-versa

Simulation definition

Universal
(simulator)
tile set

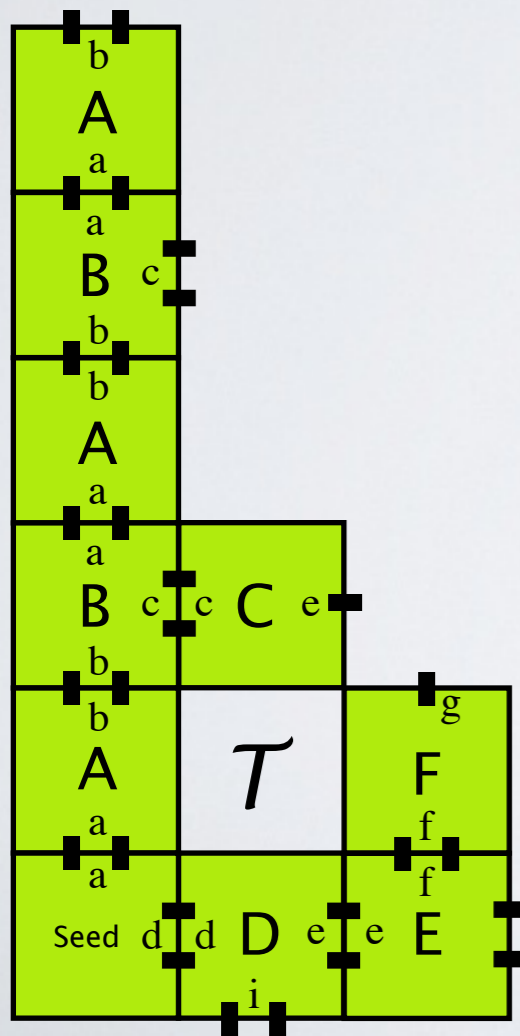
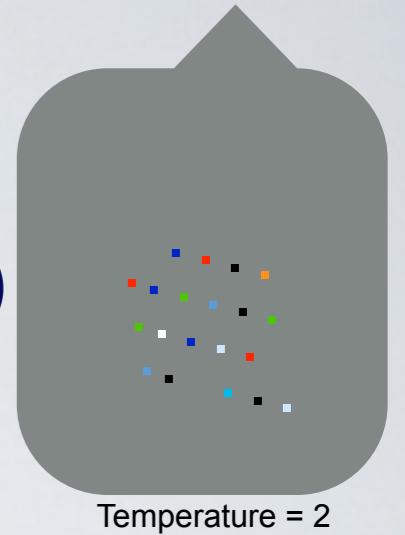

Preassembled
seed structure
(encodes simulated
TAS)

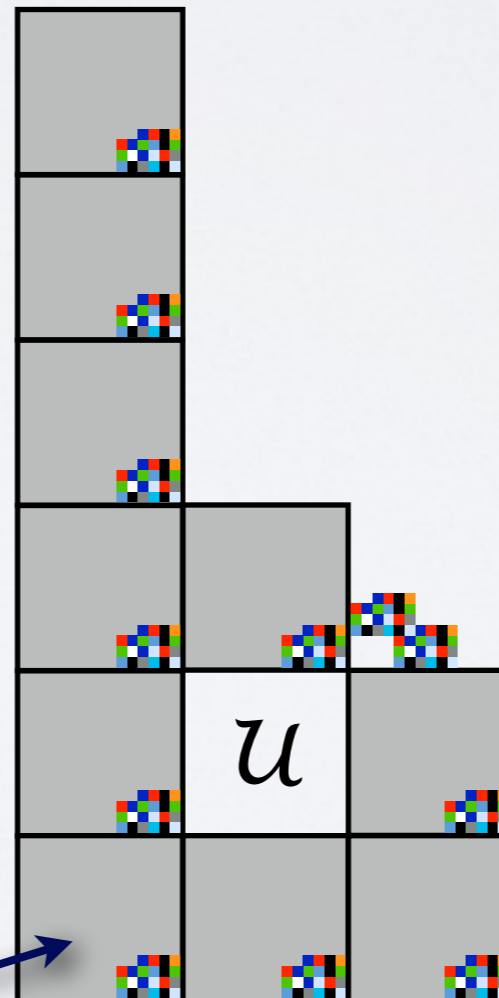

Simulated
tile

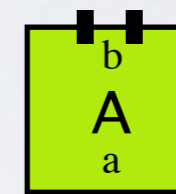

Simulator
supertile

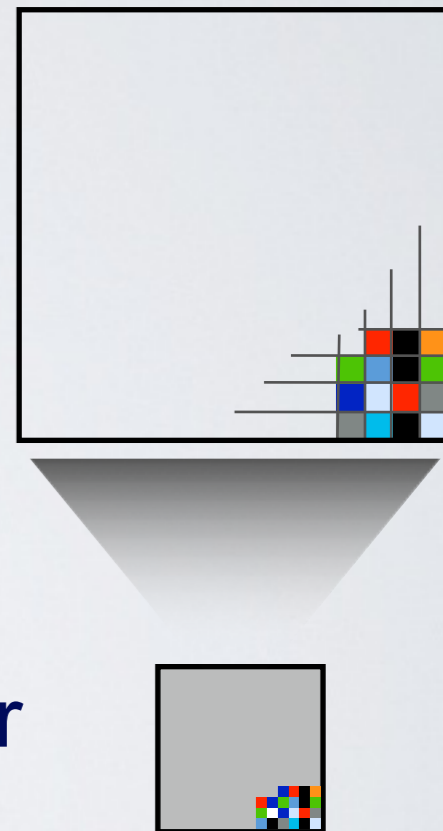

- Green tiles are simulated by supertiles
- For each assembly sequence in the simulated tile system, there is an assembly sequence in the simulator, and vice-versa

Simulation definition

Universal
(simulator)
tile set

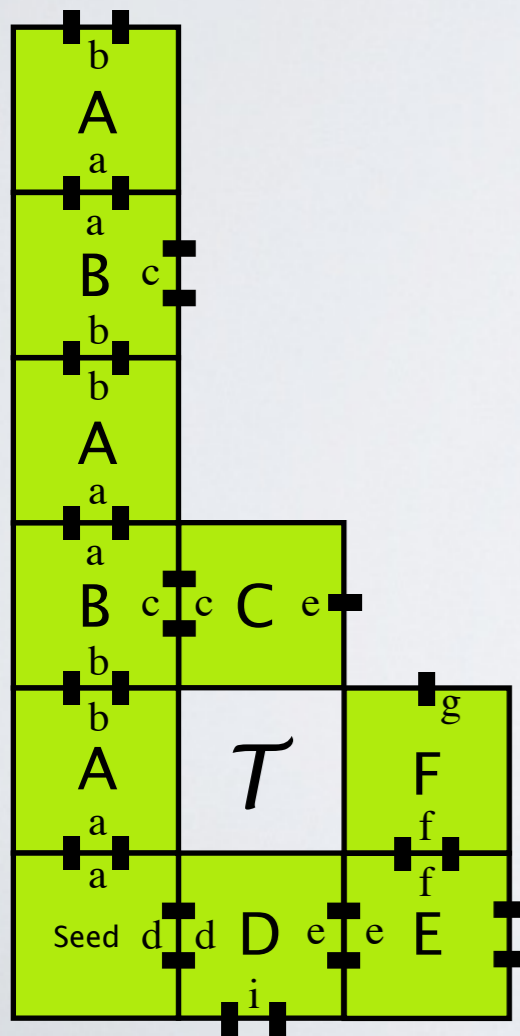
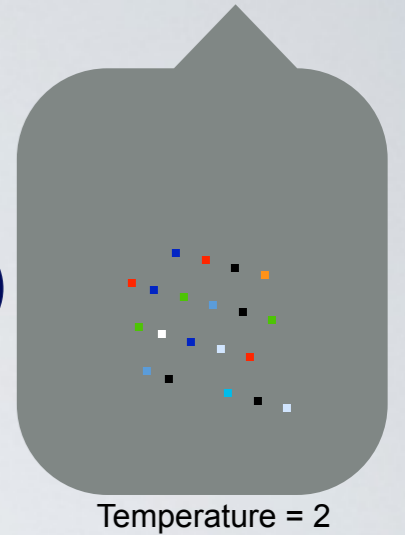

Preassembled
seed structure
(encodes simulated
TAS)

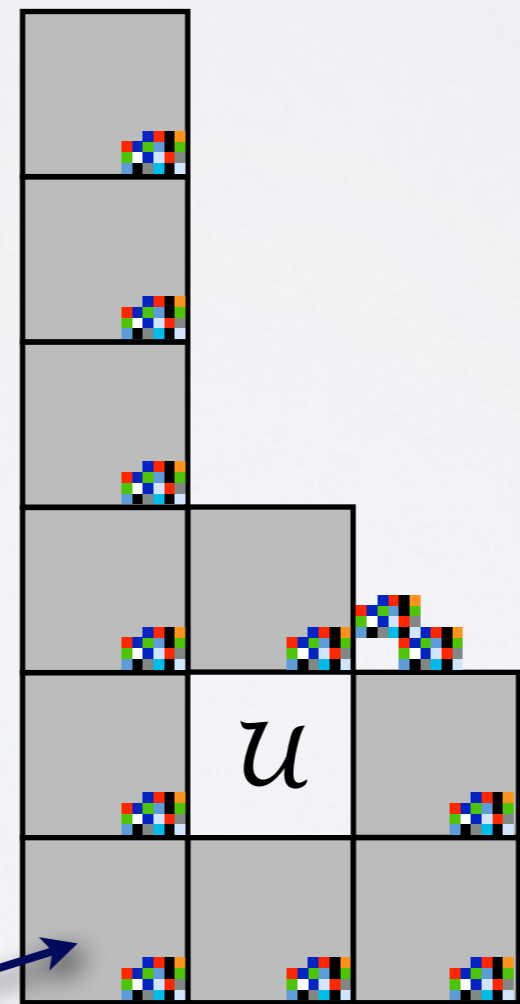

Simulated
tile

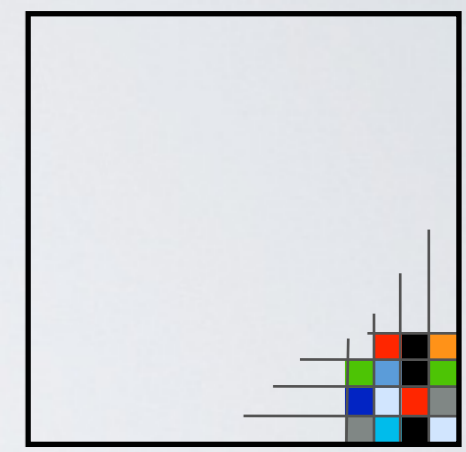
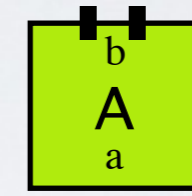

Simulator
supertile

- Green tiles are simulated by supertiles
- For each assembly sequence in the simulated tile system, there is an assembly sequence in the simulator, and vice-versa

etc.

Simulation definition

Ignoring $m \times m$ scaling, production & dynamics are equivalent in the simulated system and simulator

Universal
(simulator)
tile set

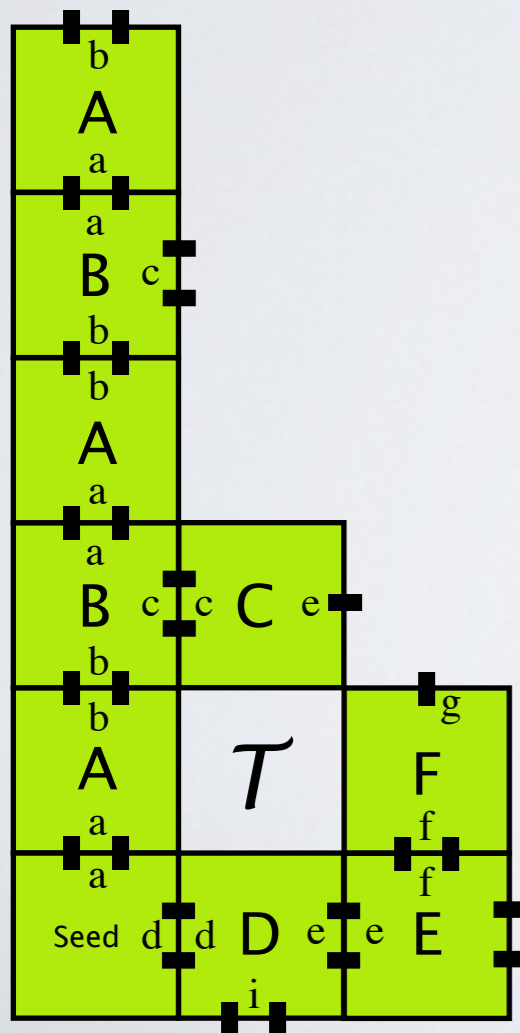
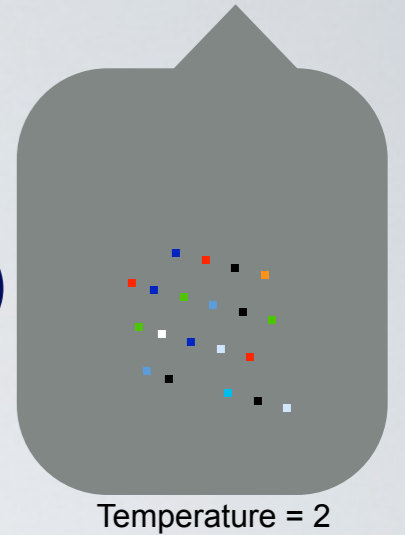

Preassembled
seed structure
(encodes simulated
TAS)

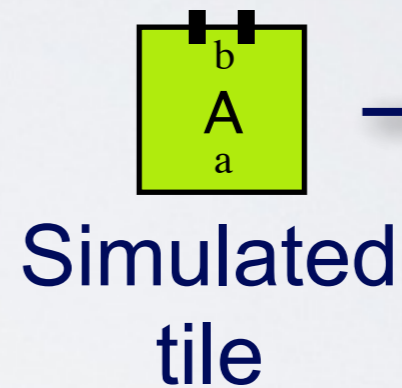
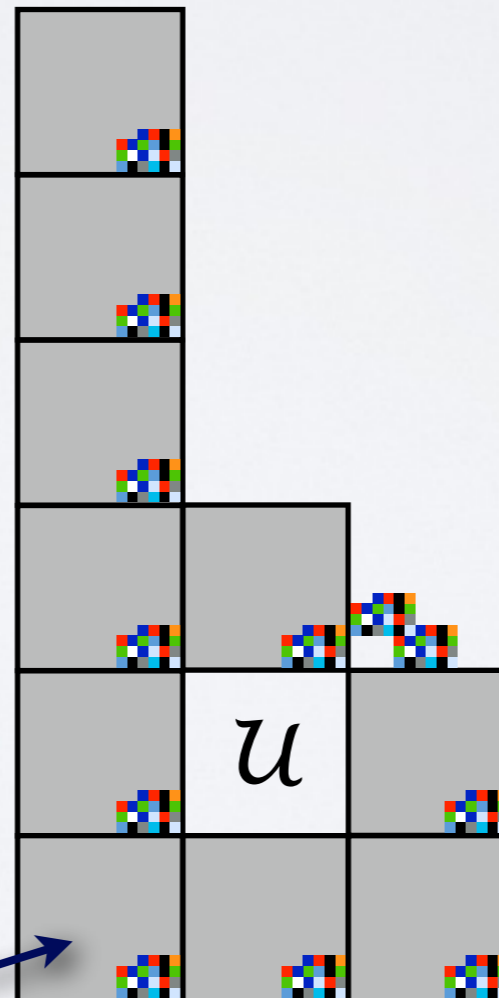

Simulator
supertile

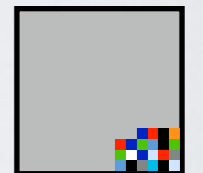

- Green tiles are simulated by supertiles
- For each assembly sequence in the simulated tile system, there is an assembly sequence in the simulator, and vice-versa

etc.

Simulation definition

- We want a definition of simulation that captures the notion of one tile assembly system simulating the “behaviour” of another
- \mathcal{T} is a (any) simulated tile assembly system,
 - $\mathcal{T} = (\text{tileset } T, \text{ seed assembly } \sigma, \text{ temperature } \tau)$
- Tile assembly system $\mathcal{U}_\tau = (U, \sigma_\tau, 2)$ simulates \mathcal{T} if:
 - Tiles from T are simulated by $m \times m$ **supertiles** in \mathcal{U}_τ
 - **Producible** assemblies in \mathcal{U}_τ represent **exactly the producible** assemblies in \mathcal{T} .
 - **Dynamics are equivalent** in \mathcal{U}_τ & \mathcal{T} , ignoring $m \times m$ scaling

Is the abstract tile assembly model intrinsically universal?

Yes!

Theorem: There is a single universal tile set U that simulates *any* tile assembly system

Doty, Lutz, Patitz, Schweller, Summers, Woods. FOCS 2012

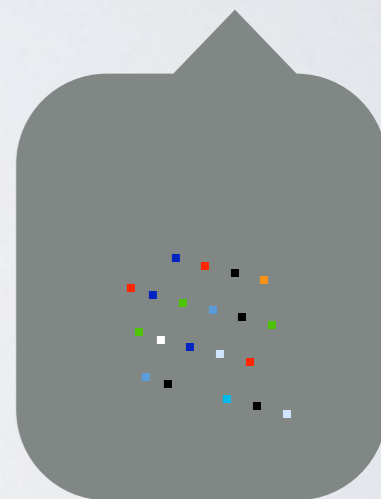

Temperature = 2

Universal
tile set

Superside

Encoding of the entire simulated **tile assembly system** written down using tiles from the simulator U

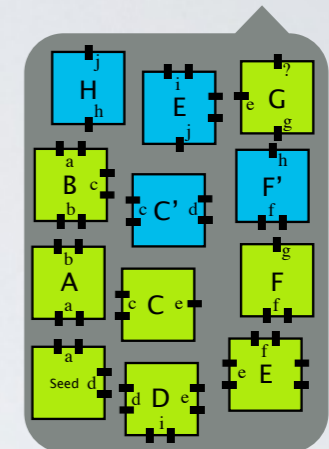

Temperature = 2

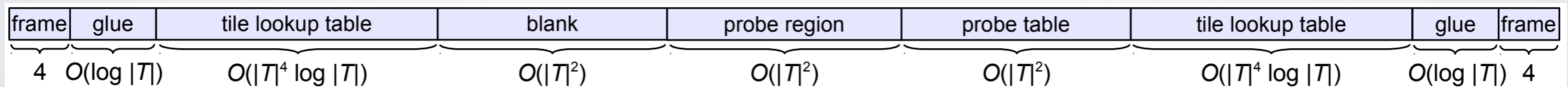

$|T|$ is number of tiles in the simulated tileset T .

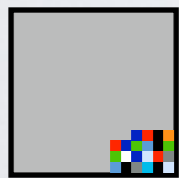
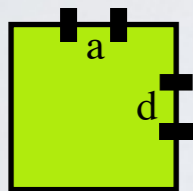

Preassembled
seed supertile

Tiles from the universal tile set U
are arranged so that they encode
some simulated tile assembly system \mathcal{T}



Superside

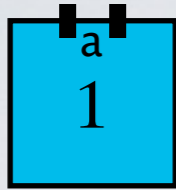

Encoded glue of this superside (e.g. "a")

Encoding of the entire simulated tile assembly system written down using tiles from the simulator U

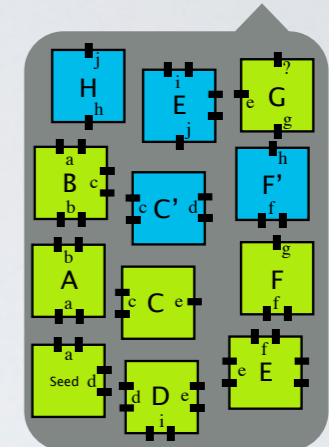

frame	glue	tile lookup table	blank	probe region	probe table	tile lookup table	glue	frame
4	$O(\log T)$	$O(T ^4 \log T)$	$O(T ^2)$	$O(T ^2)$	$O(T ^2)$	$O(T ^4 \log T)$	$O(\log T)$	4

Encoding of tile type 1 from T

$|T|$ is number of tiles in the simulated tileset T .

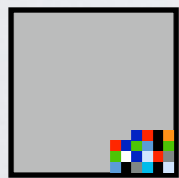
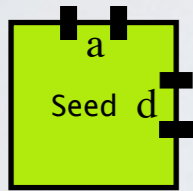

Preassembled seed supertile

seed supertile

Tiles from the universal tile set U are arranged so that they encode some simulated tile assembly system T

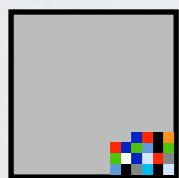
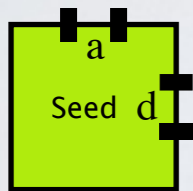

Preassembled seed supertile

One-sided binding with a single strength- τ south superside

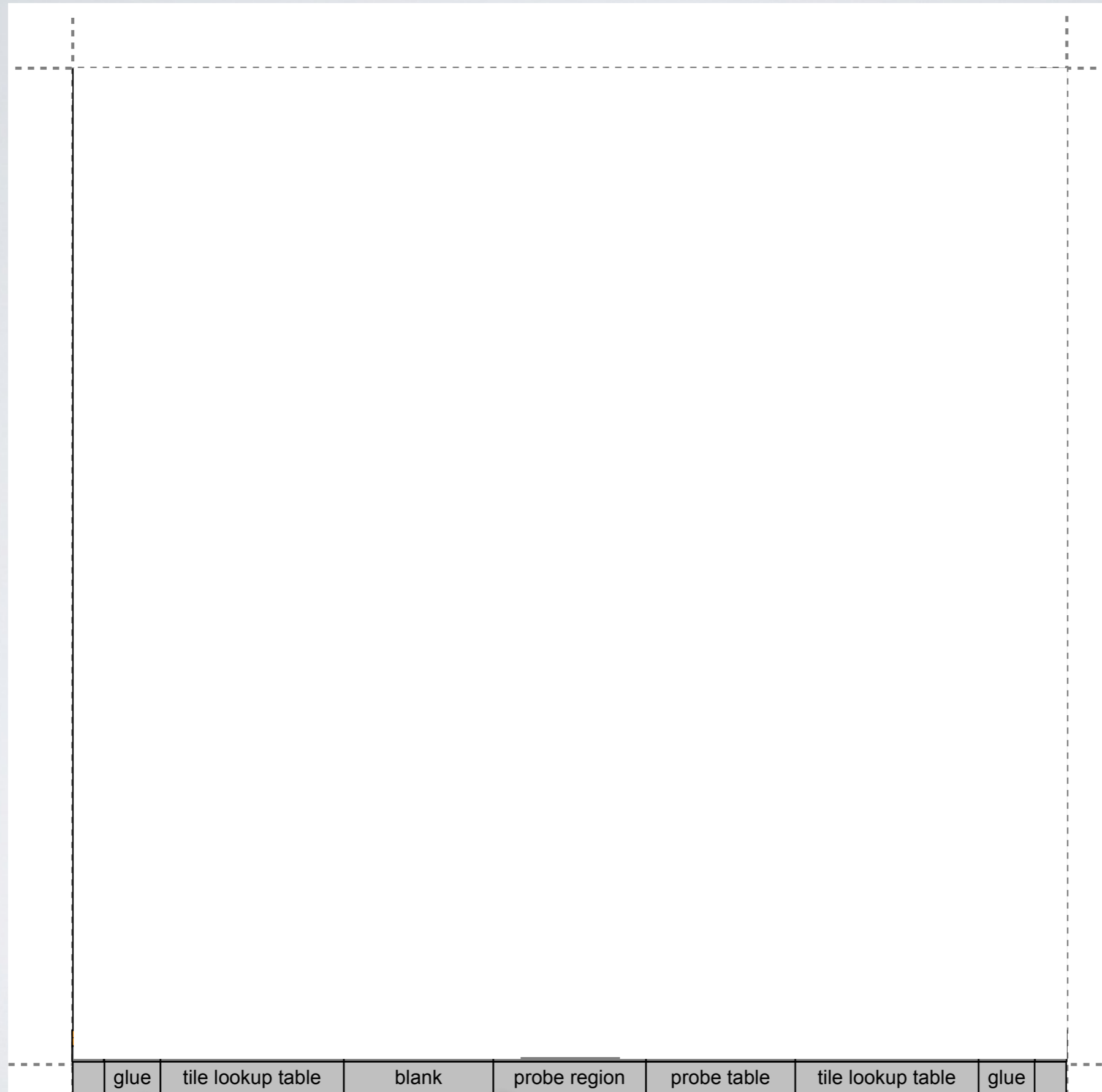
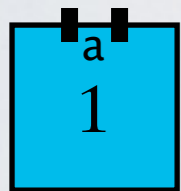

glue

tile lookup table

blank

probe region

probe table

tile lookup table

glue

Glue "a" is encoded here

Supertile 1

Tile set T is encoded here

Glue "a" is encoded here

One-sided binding with a single strength- τ south superside

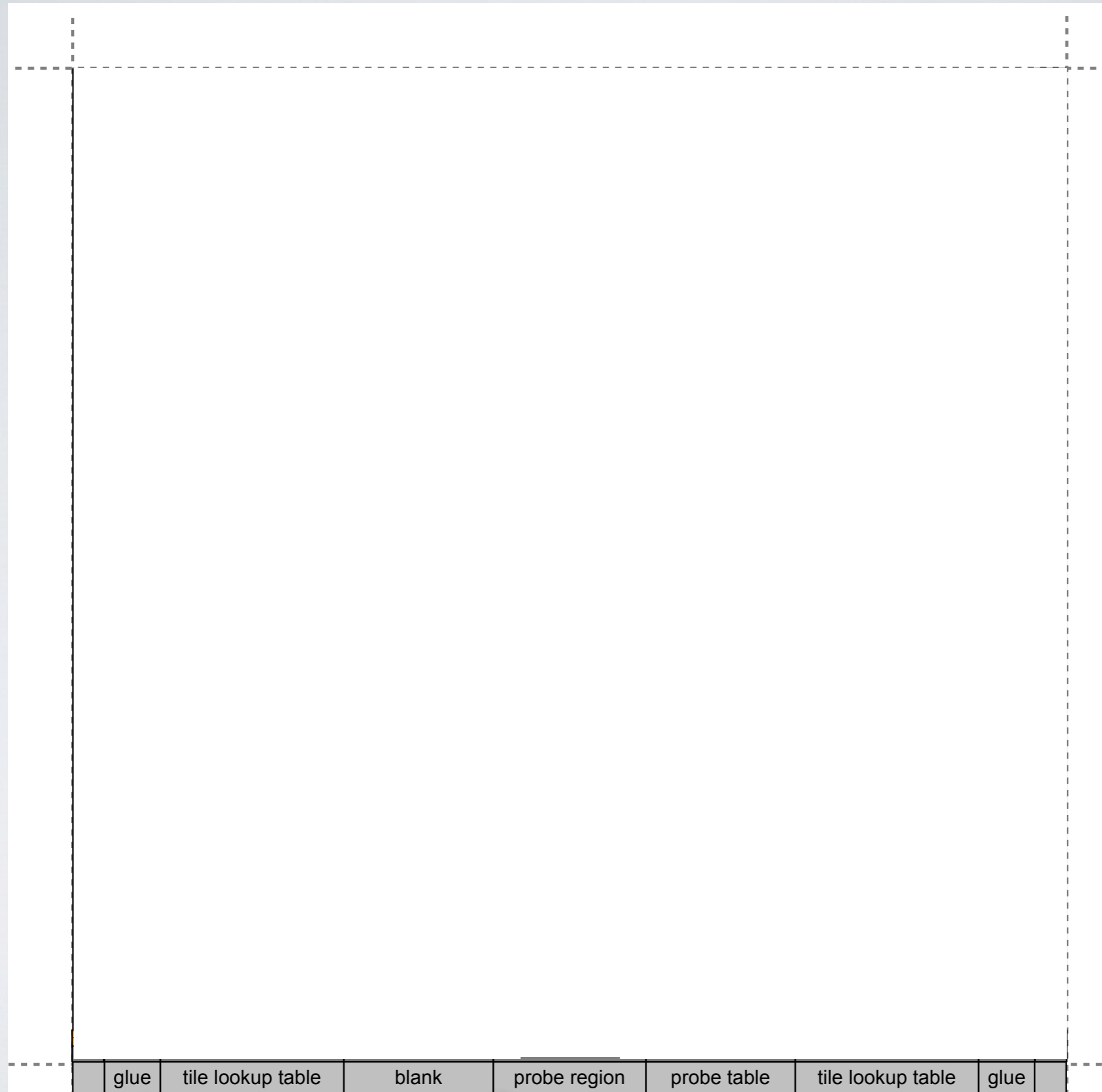
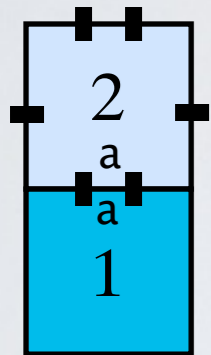

glue

tile lookup table

blank

probe region

probe table

tile lookup table

glue

Glue "a" is encoded here

Supertile 1

Tile set T is encoded here

Glue "a" is encoded here

One-sided binding with a single strength- τ south superside

Goal: place a description of T and "tile 2" around the 4 super-edges

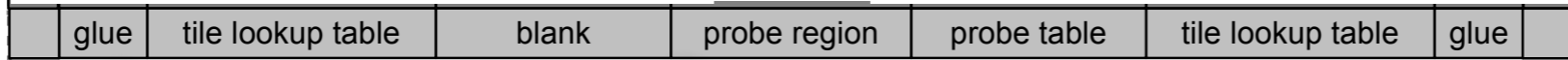
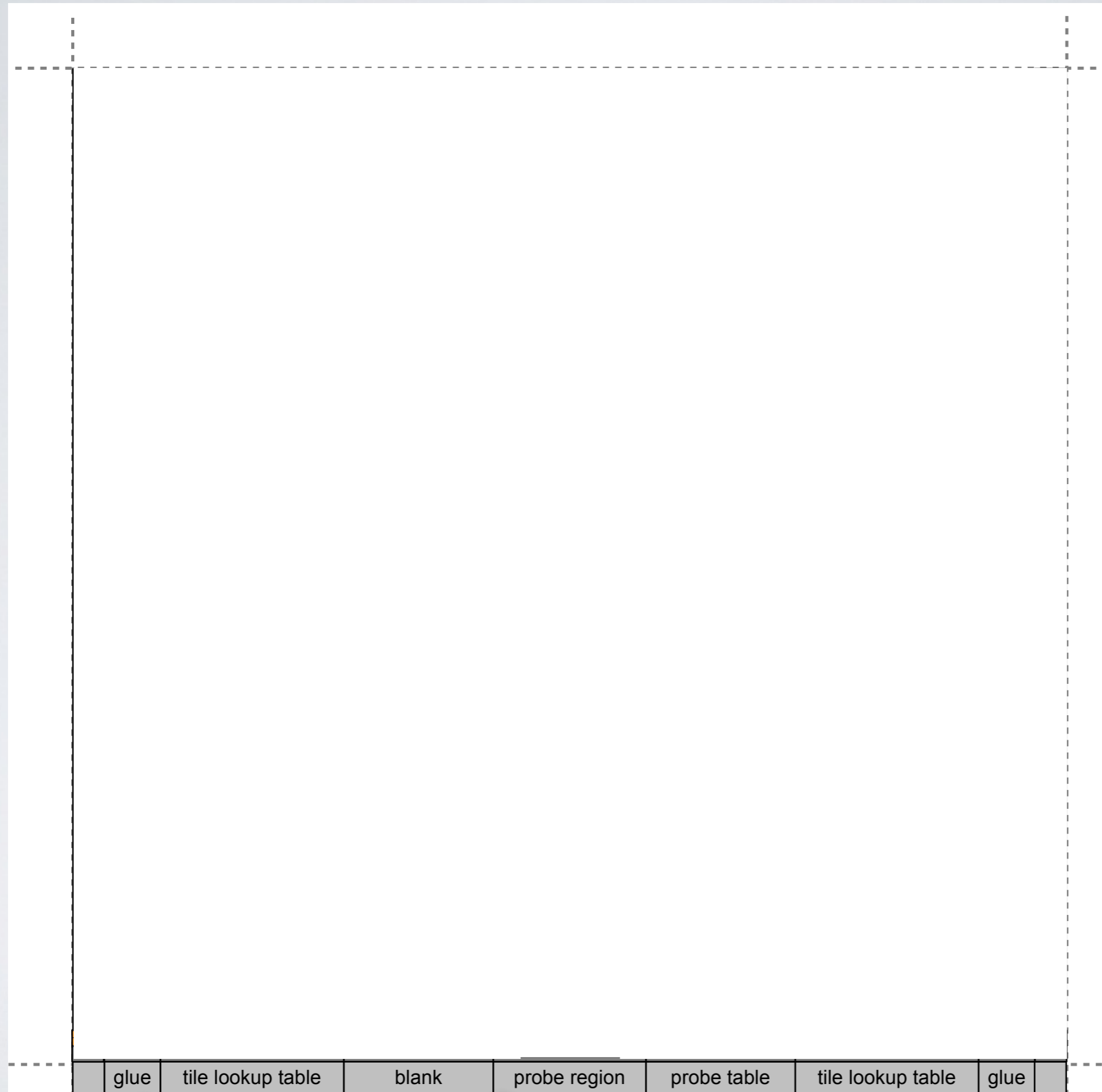
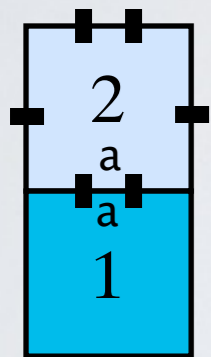

Glue "a" is encoded here

Supertile 1

Tile set T is encoded here

Glue "a" is encoded here

One-sided binding with a single strength- τ south superside

Goal: place a description of T and "tile 2" around the 4 super-edges

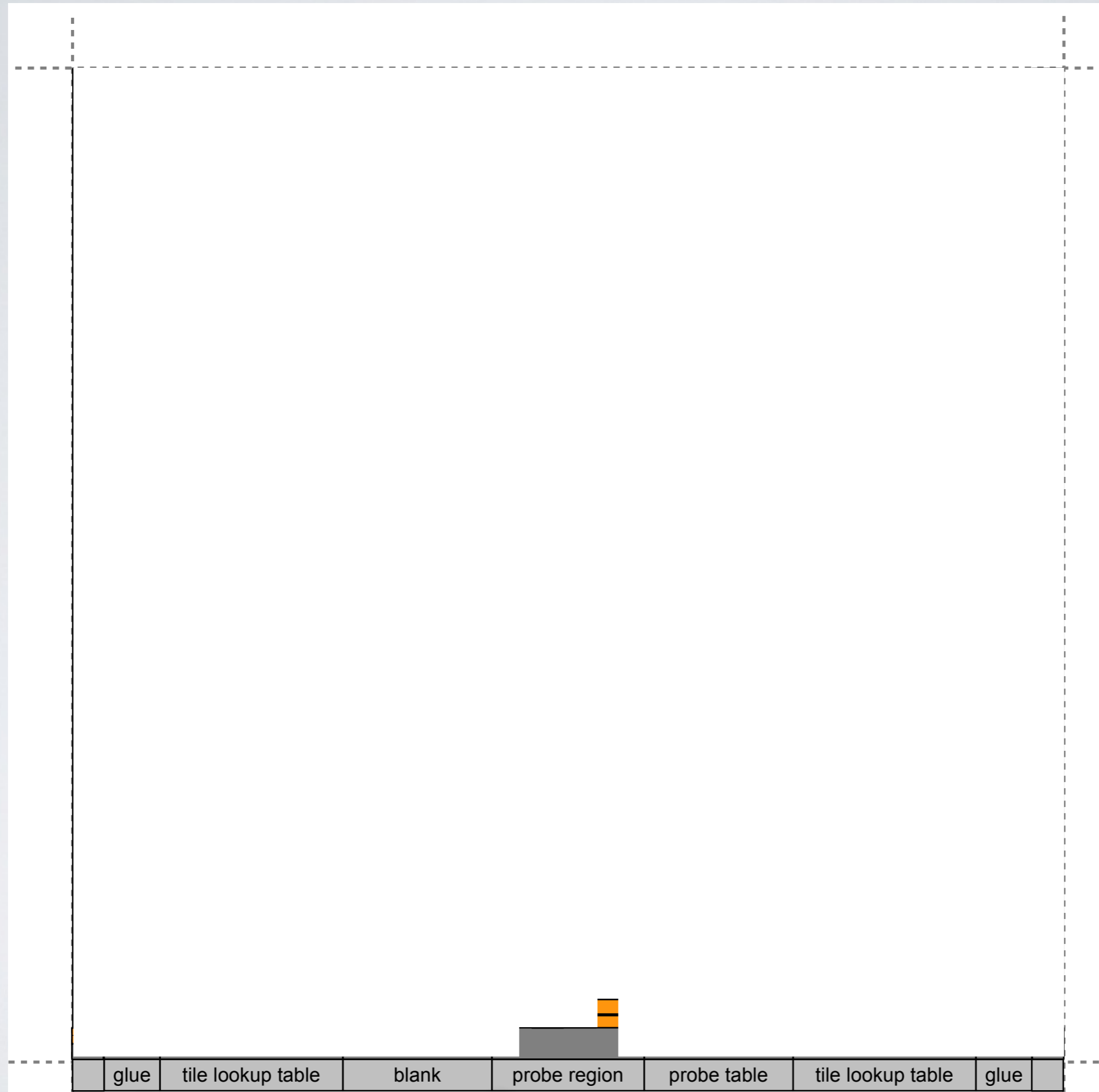
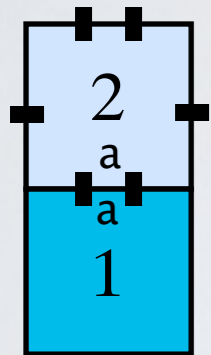

Glue "a" is encoded here

Supertile 1

Tile set T is encoded here

Glue "a" is encoded here

One-sided binding with a single strength- τ south superside

Goal: place a description of T and "tile 2" around the 4 super-edges

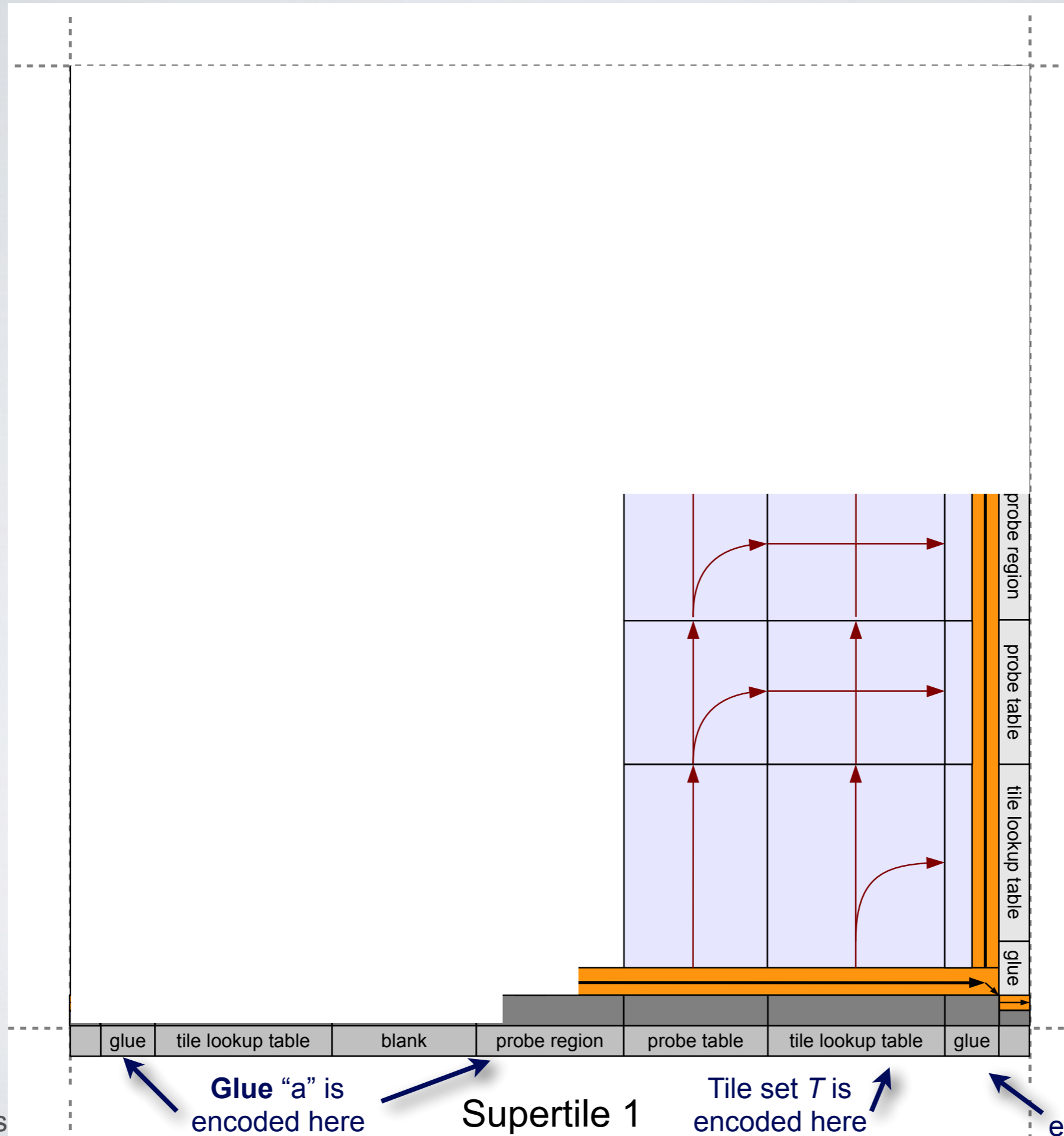
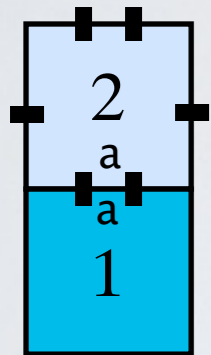

Glue "a" is encoded here

Supertile 1

Tile set T is encoded here

Glue "a" is encoded here

One-sided binding with a single strength- τ south superside

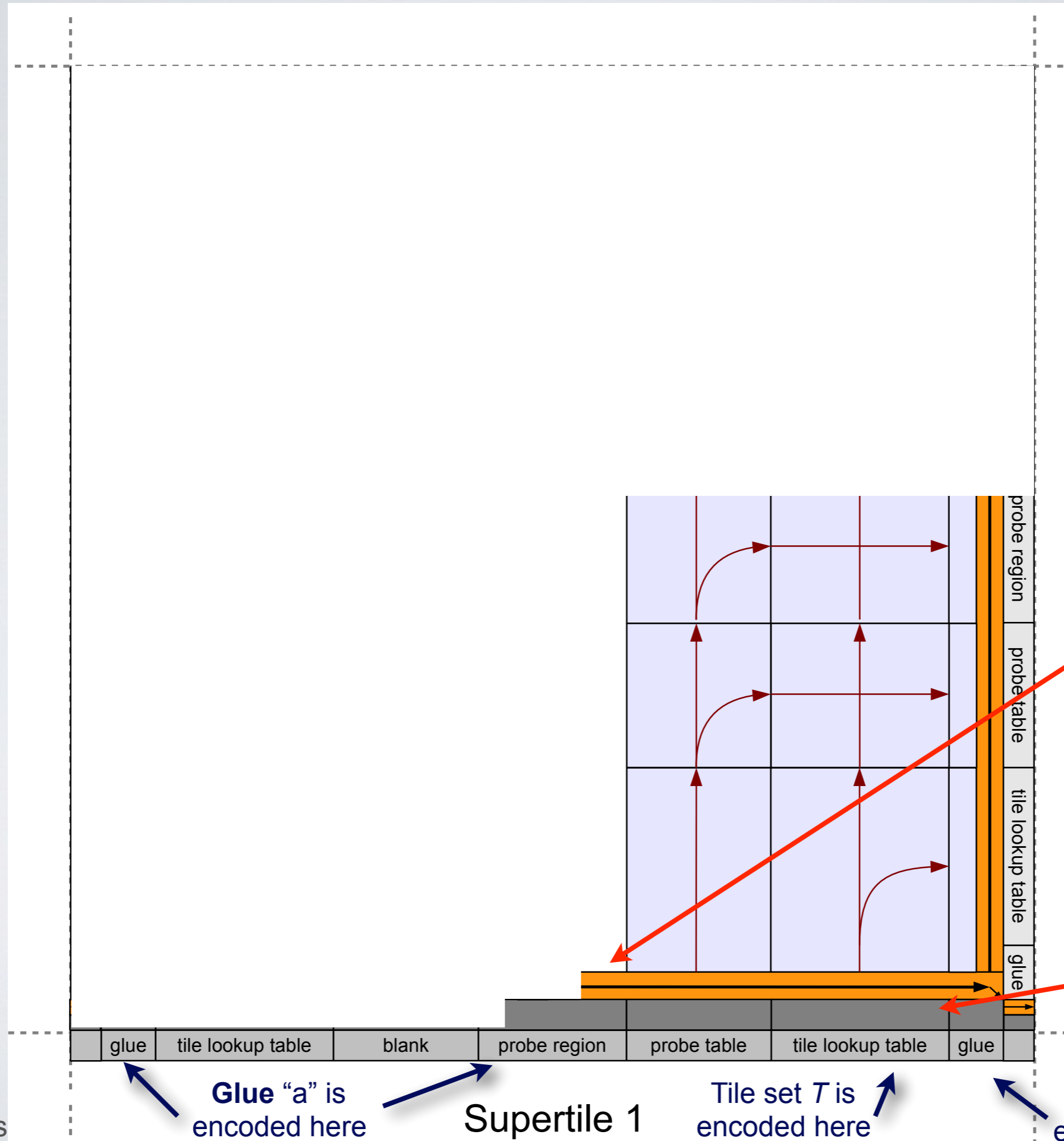
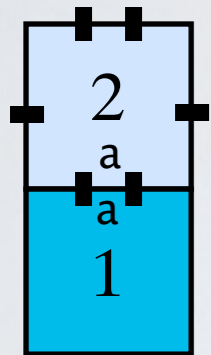

Goal: place a description of T and "tile 2" around the 4 super-edges

crawler encodes glue of south superside

"Genome" is copied

"Genome" is read

Glue "a" is encoded here

Supertile 1

Tile set T is encoded here

Glue "a" is encoded here

One-sided binding with a single strength- τ south superside

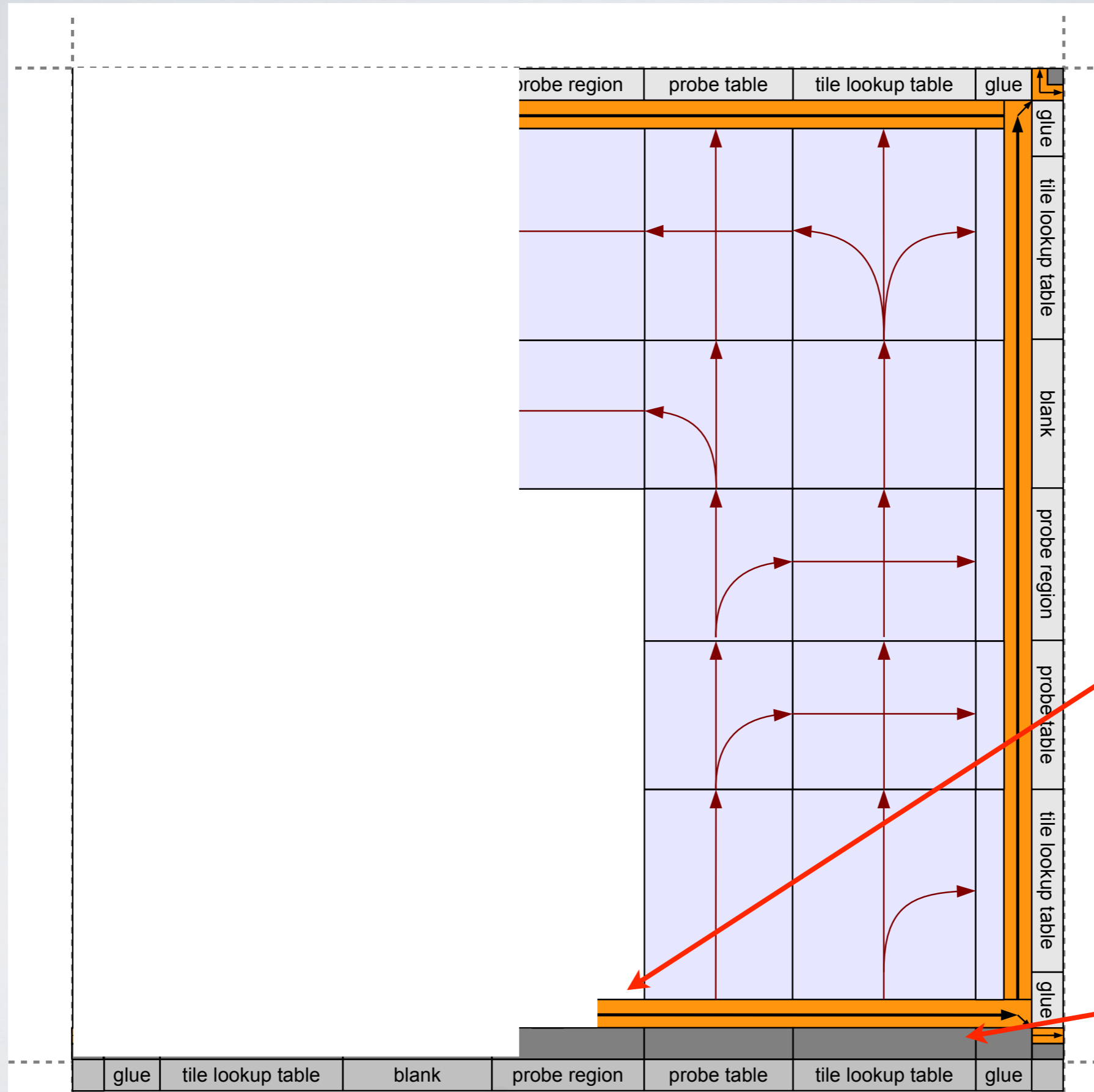
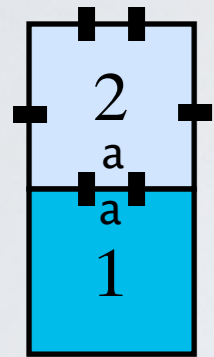

Goal: place a description of T and "tile 2" around the 4 super-edges

crawler encodes glue of south superside

"Genome" is copied

"Genome" is read

Glue "a" is encoded here

Supertile 1

Tile set T is encoded here

Glue "a" is encoded here

One-sided binding with a single strength- τ south superside

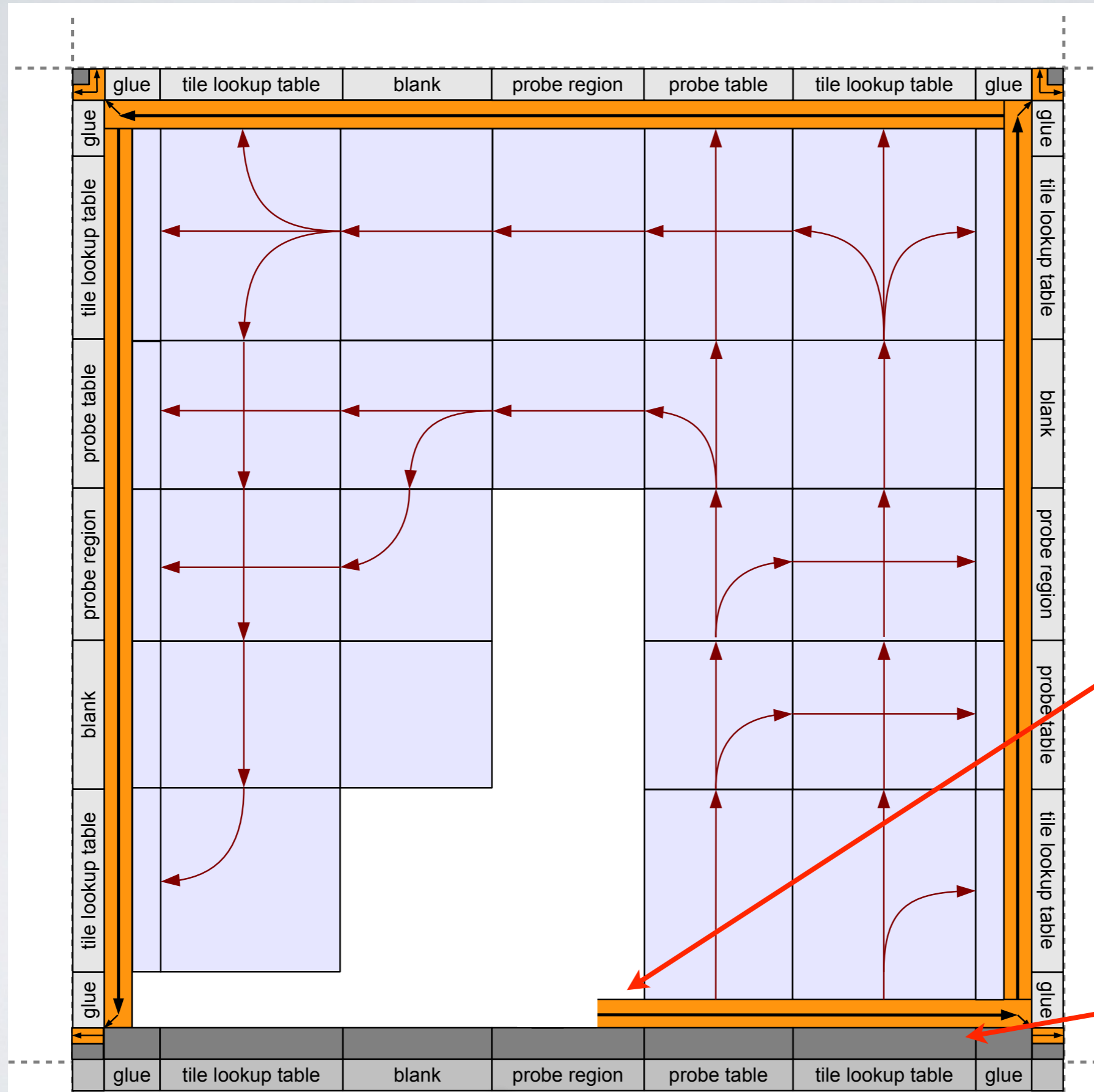
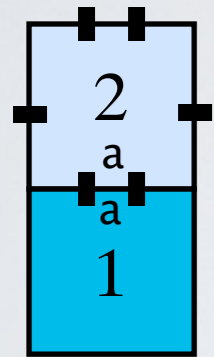

Goal: place a description of T and "tile 2" around the 4 super-edges

crawler encodes glue of south superside

"Genome" is copied

"Genome" is read

Glue "a" is encoded here

Supertile 1

Tile set T is encoded here

Glue "a" is encoded here

One-sided binding with a single strength- τ south superside

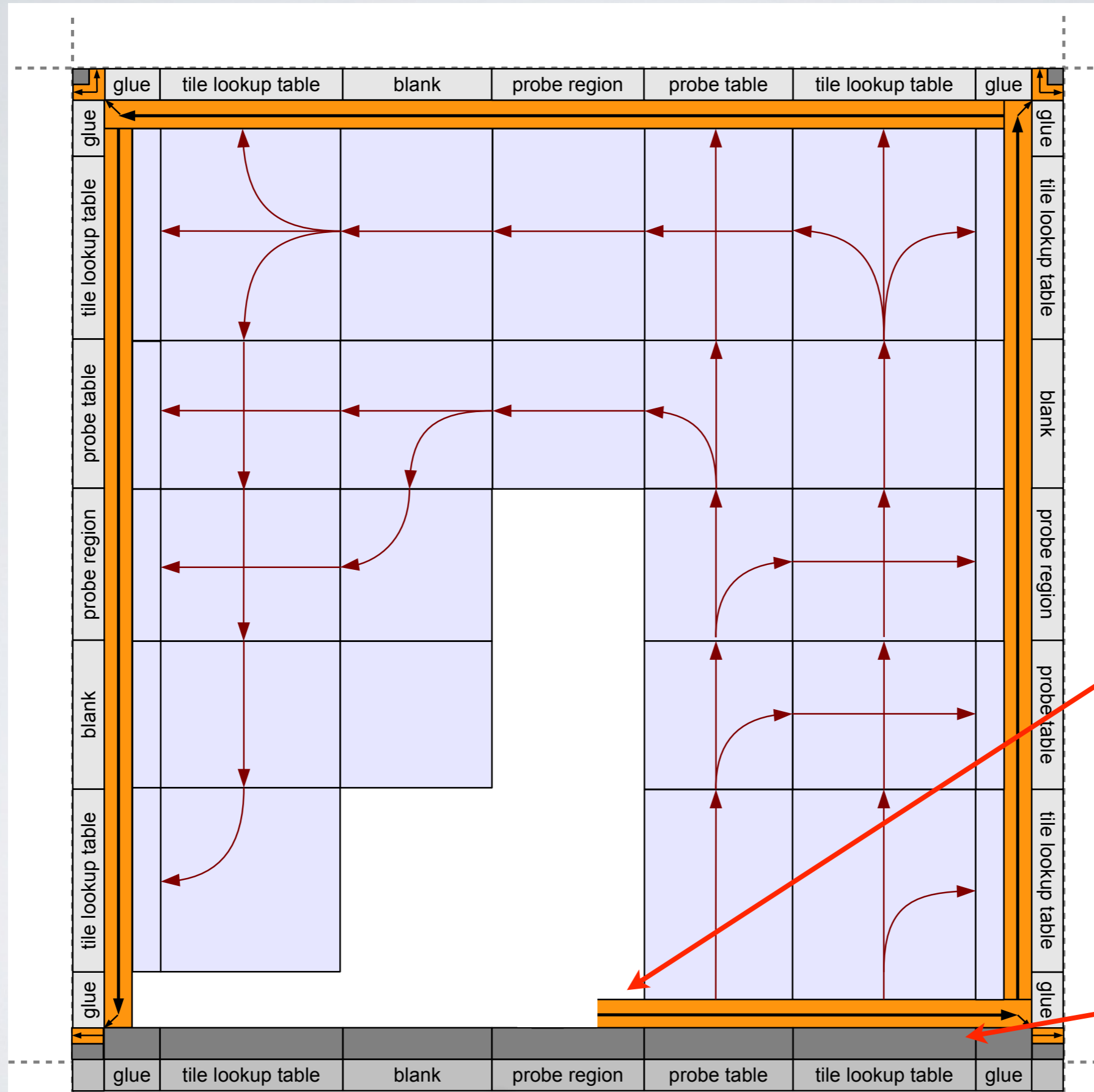
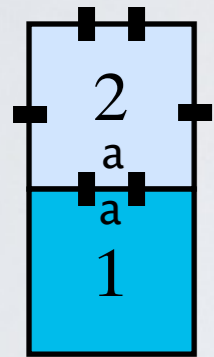

Goal: place a description of T and "tile 2" around the 4 super-edges

Nondeterminism Rotations

crawler encodes glue of south superside

"Genome" is copied

"Genome" is read

Glue "a" is encoded here

Supertile 1

Tile set T is encoded here

Glue "a" is encoded here

Crawler doing a tile lookup

crawler encodes "input" glues

crawler encodes "output" tile type

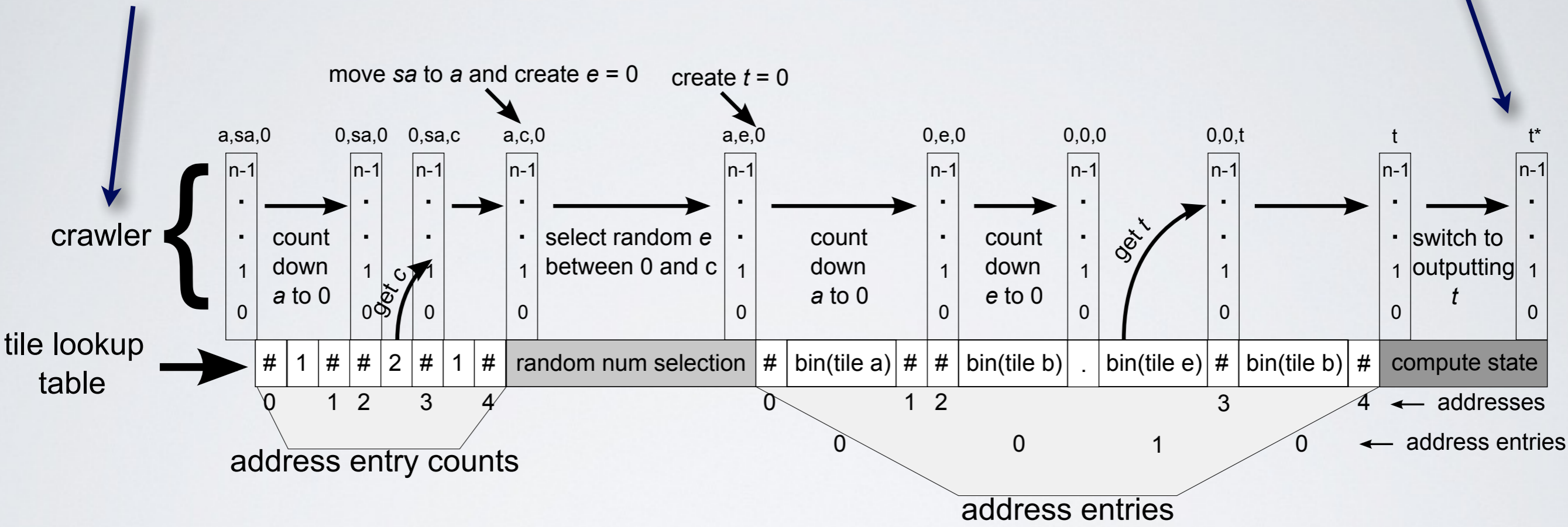

Two-sided binding with adjacent cooperating supersides

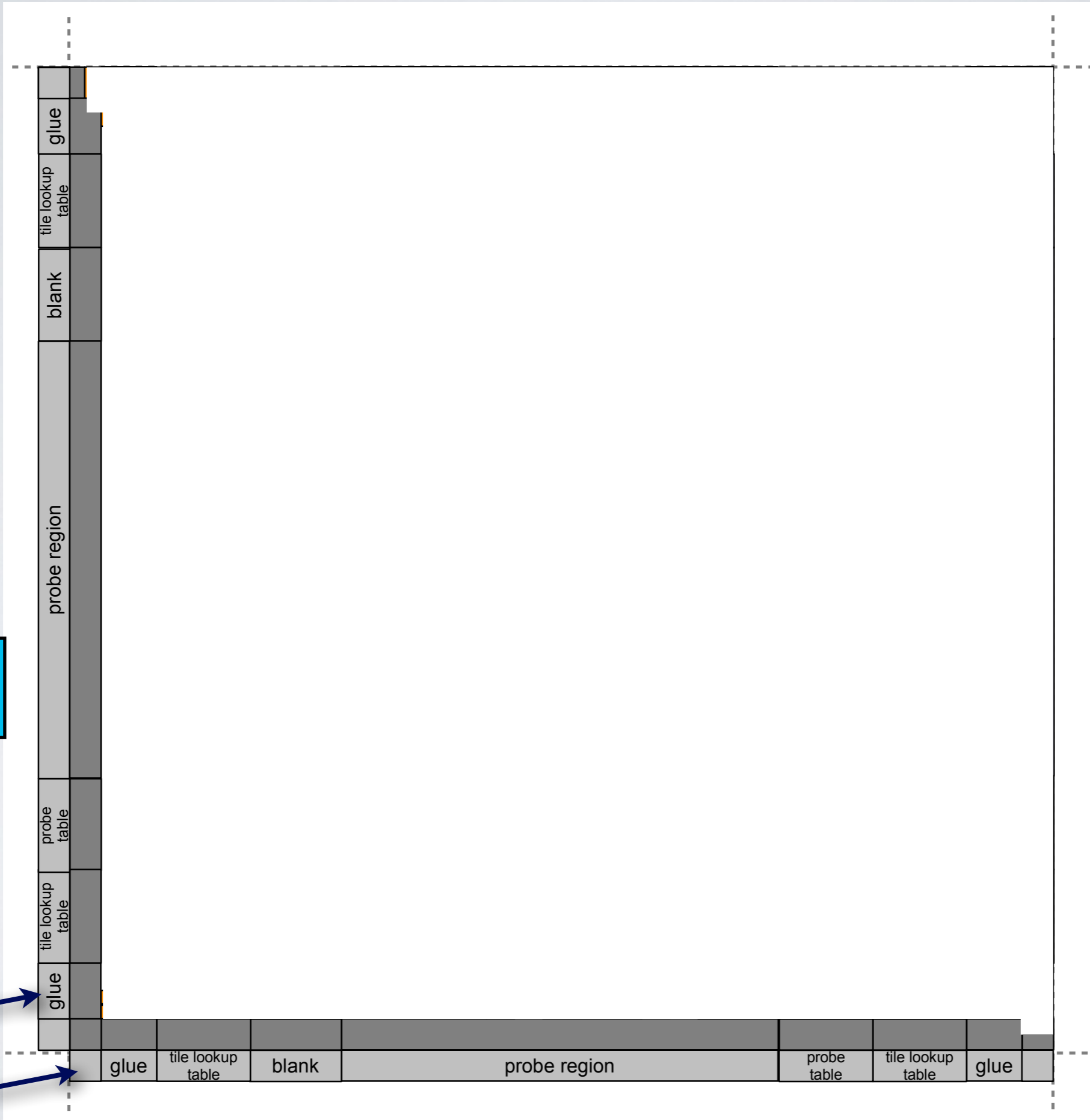

Glue "c" is encoded here

Glue "a" is encoded here

Two-sided binding with adjacent cooperating supersides

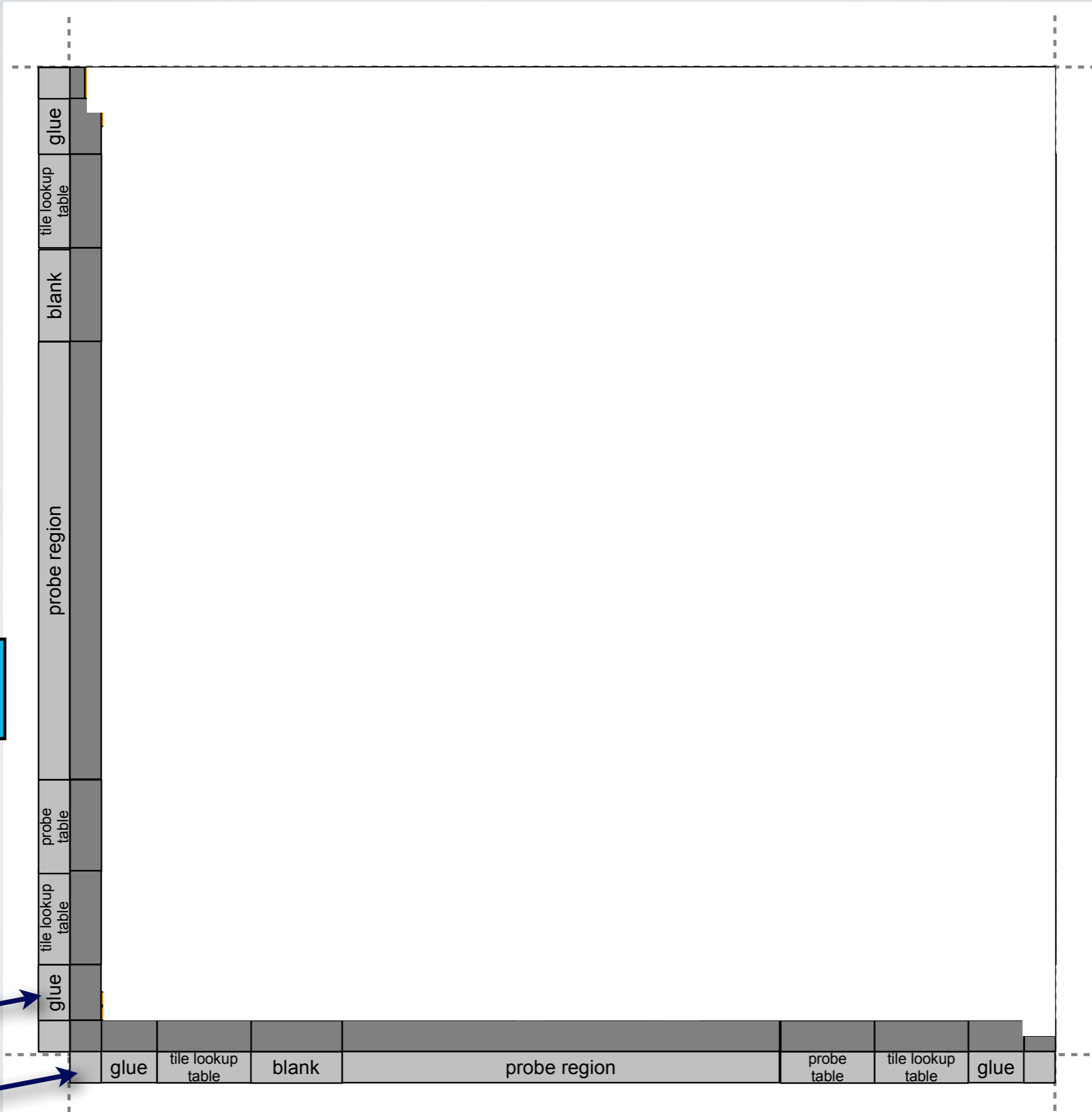

Glue "c" is encoded here

Glue "a" is encoded here

Two-sided binding with adjacent cooperating supersides

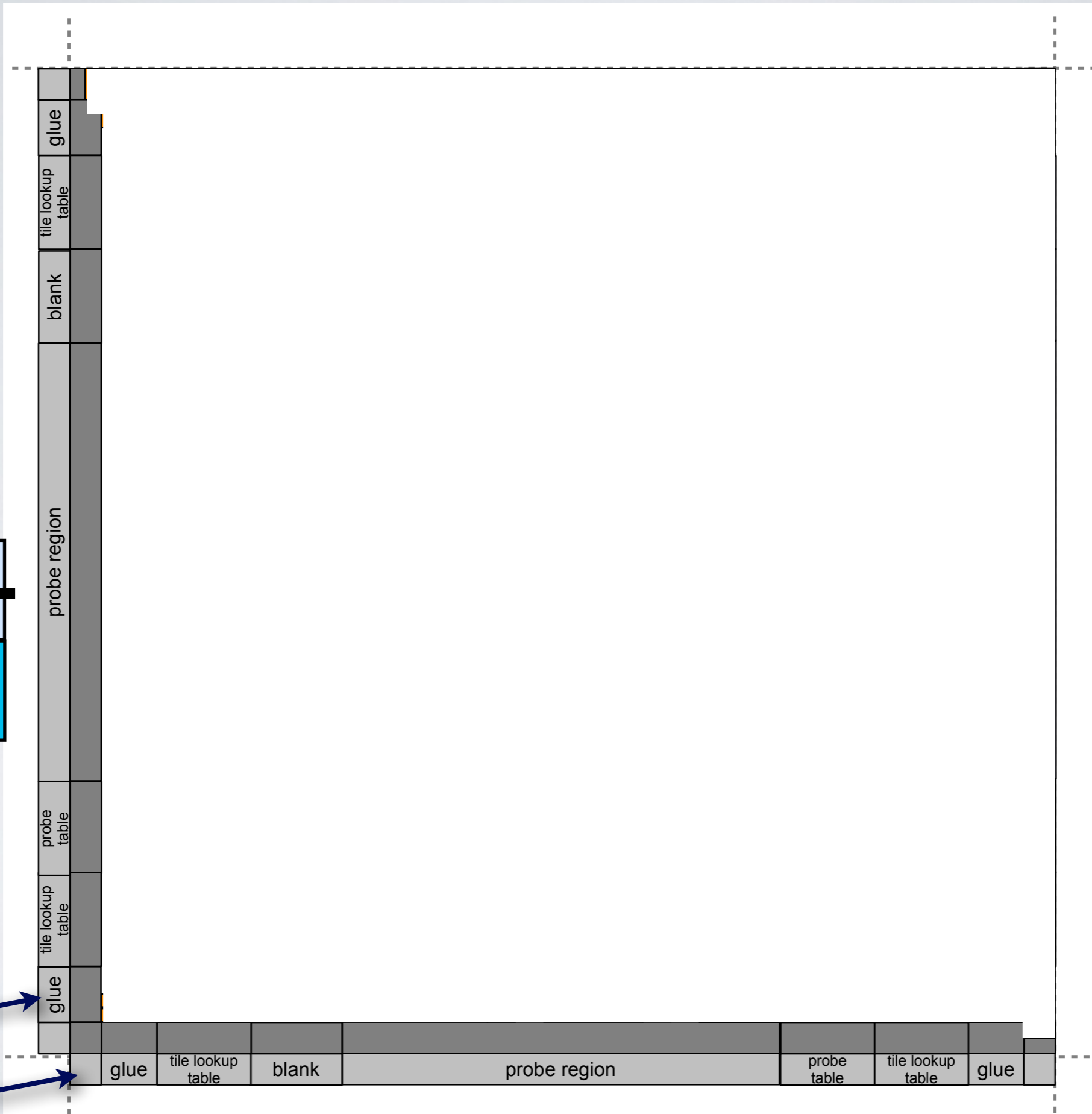
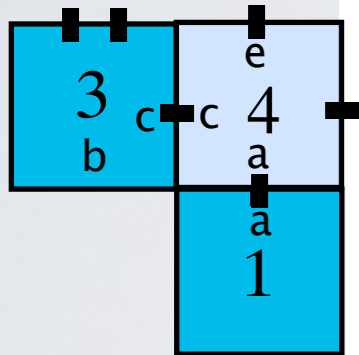

Glue "c" is encoded here

Glue "a" is encoded here

Two-sided binding with adjacent cooperating supersides

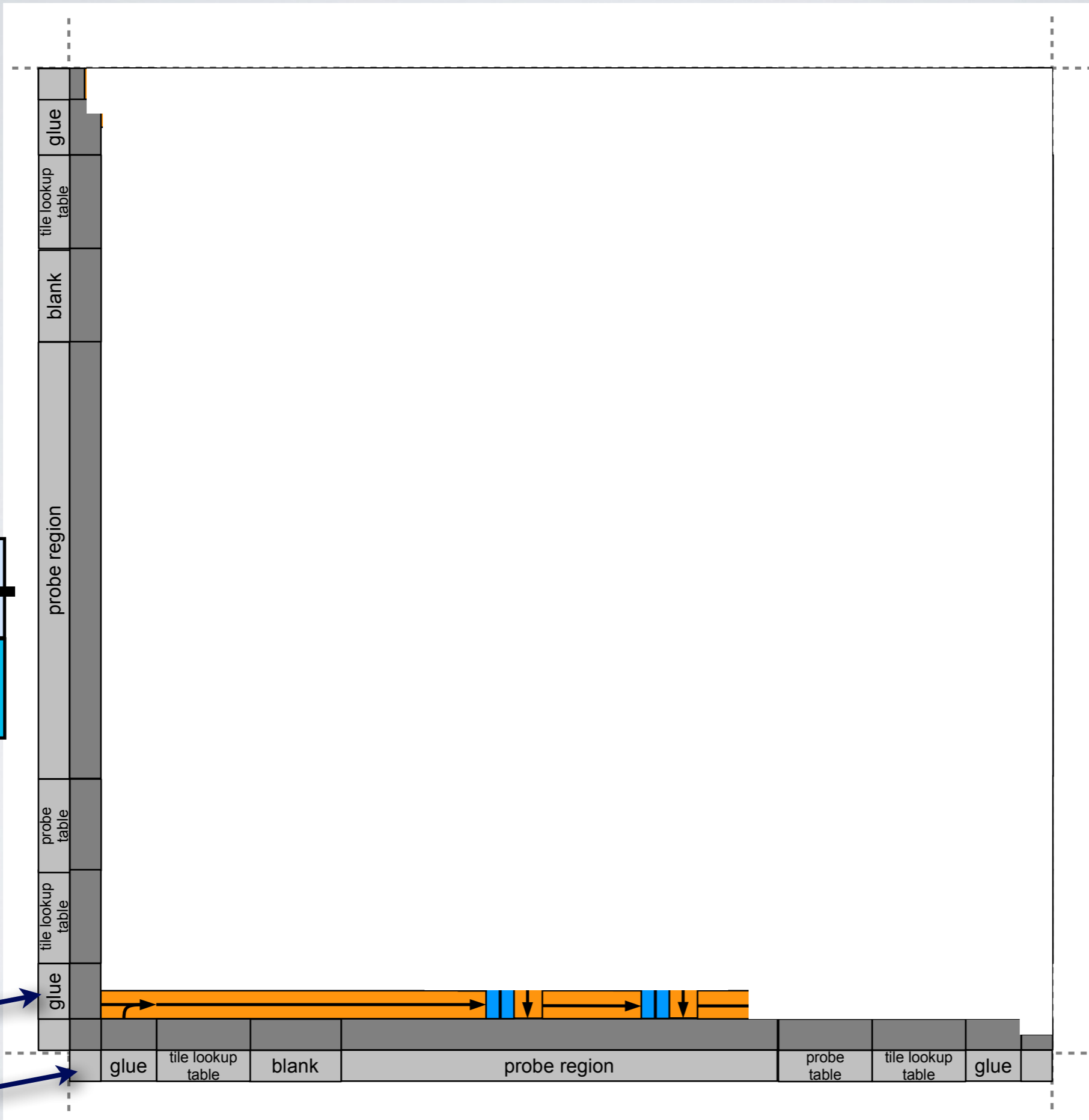
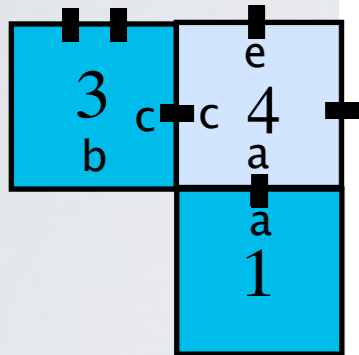

Glue "c" is encoded here

Glue "a" is encoded here

Two-sided binding with adjacent cooperating supersides

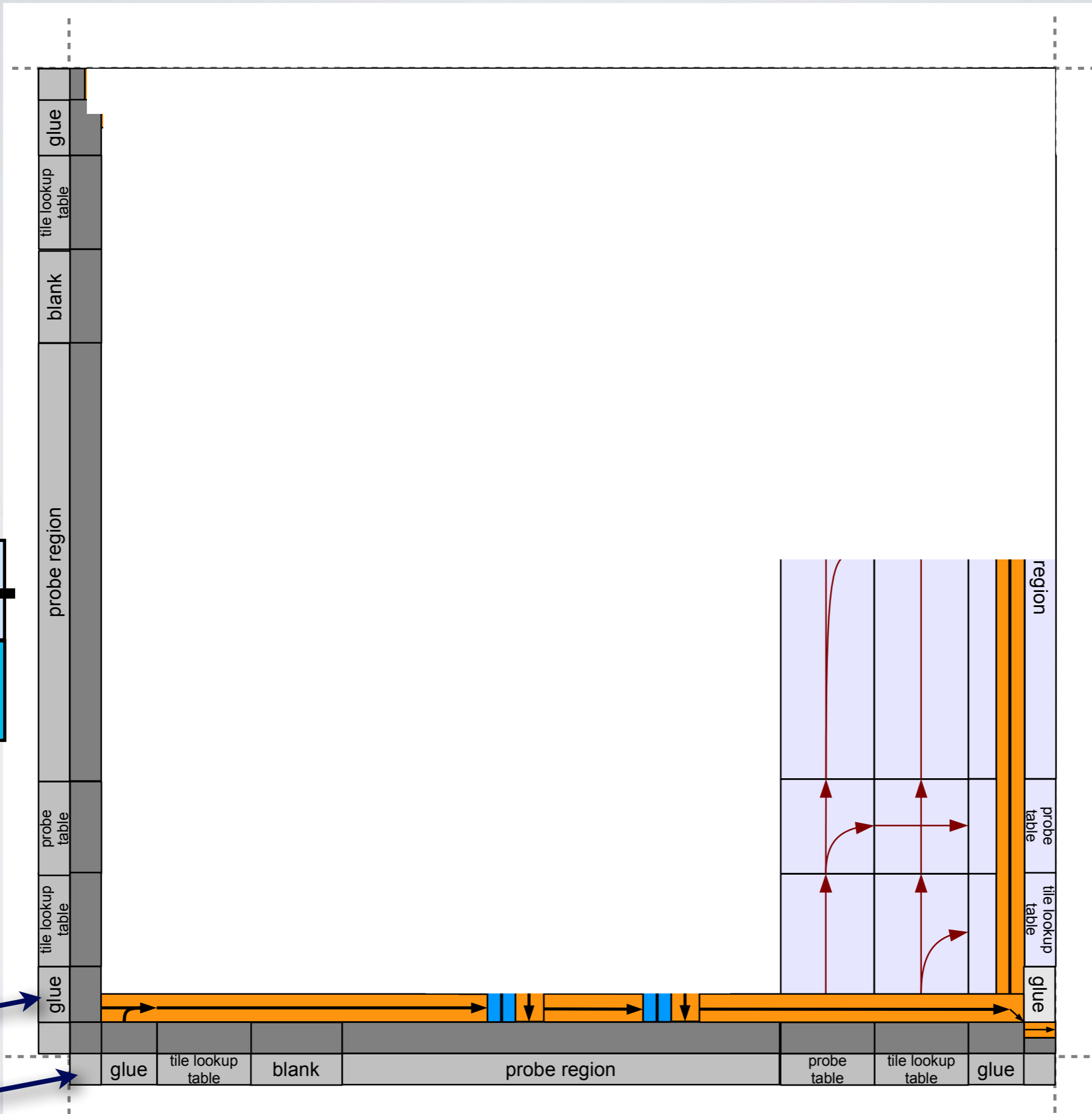
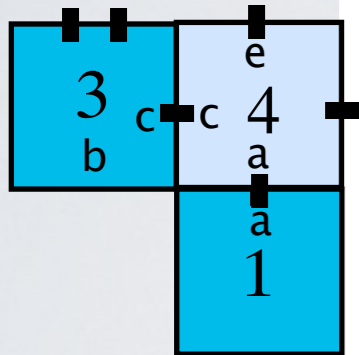

Glue "c" is encoded here

Glue "a" is encoded here

Two-sided binding with adjacent cooperating supersides

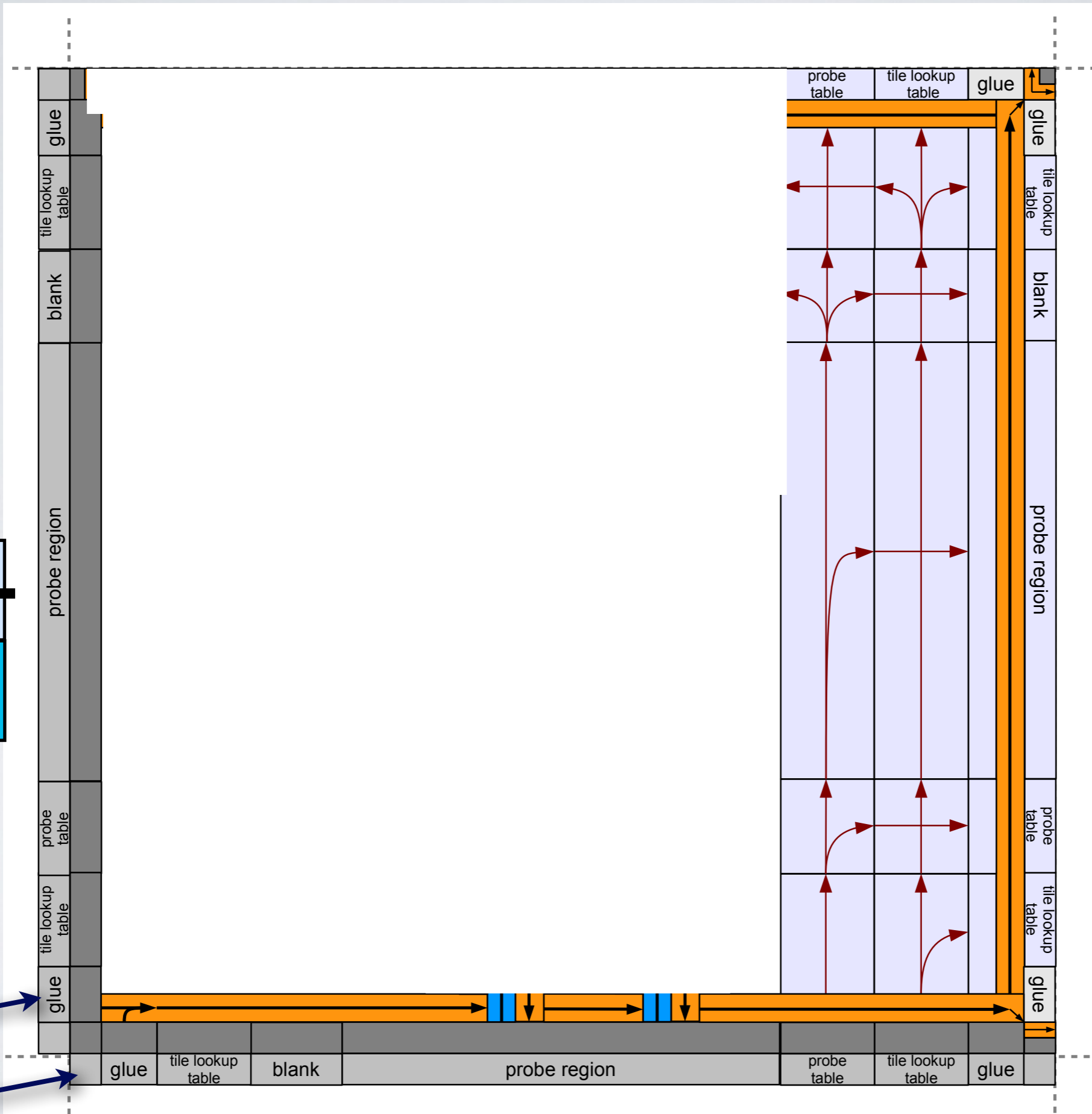
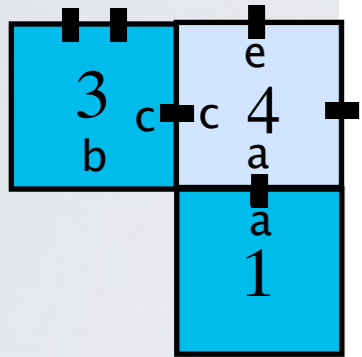

Glue "c" is encoded here

Glue "a" is encoded here

Two-sided binding with adjacent cooperating supersides

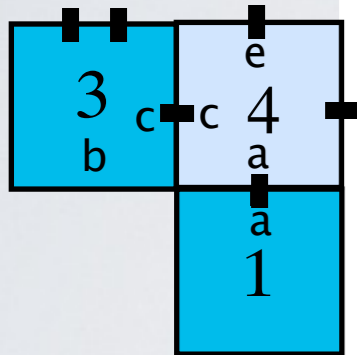
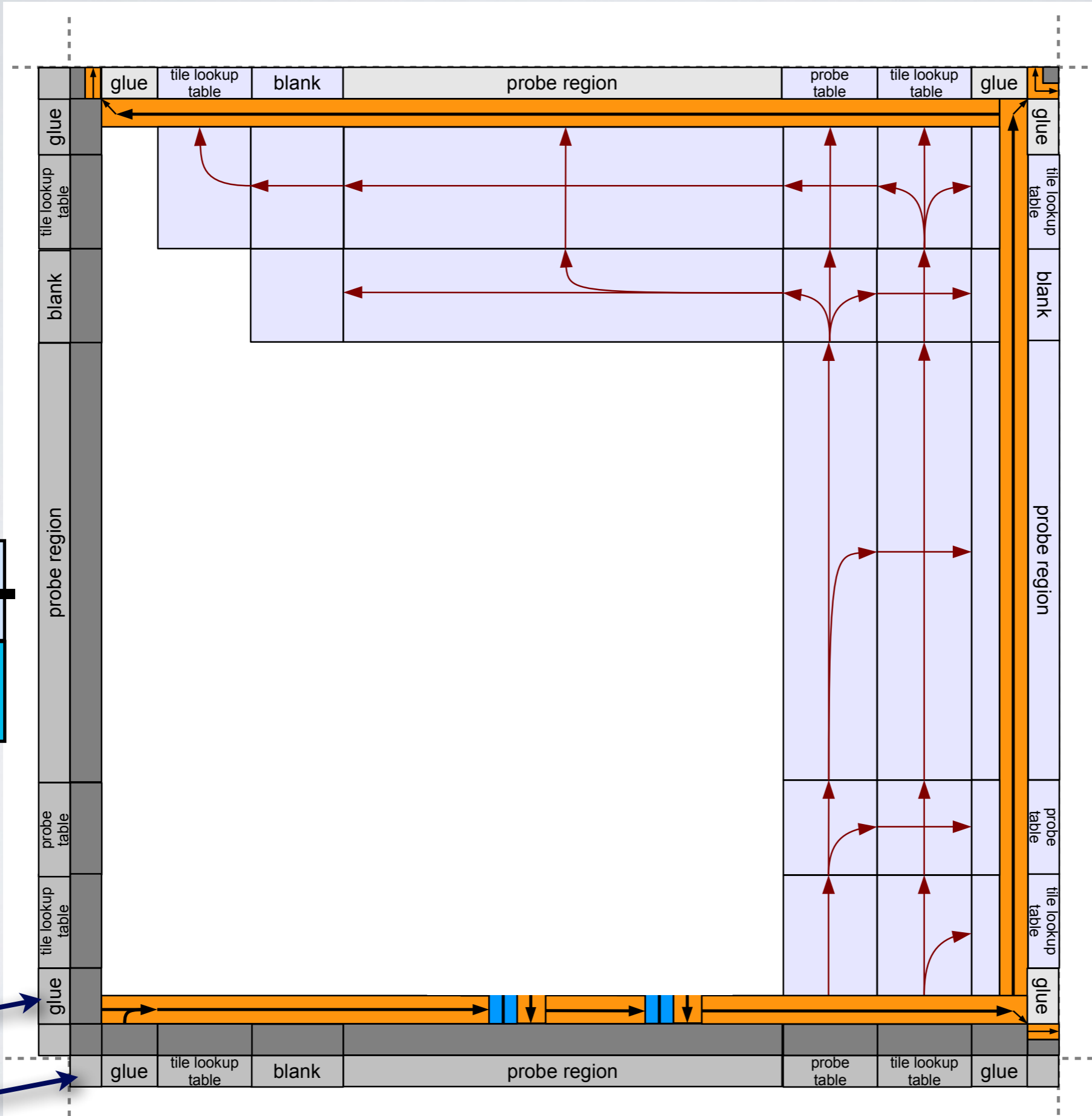

Glue "c" is encoded here

Glue "a" is encoded here

A key problem

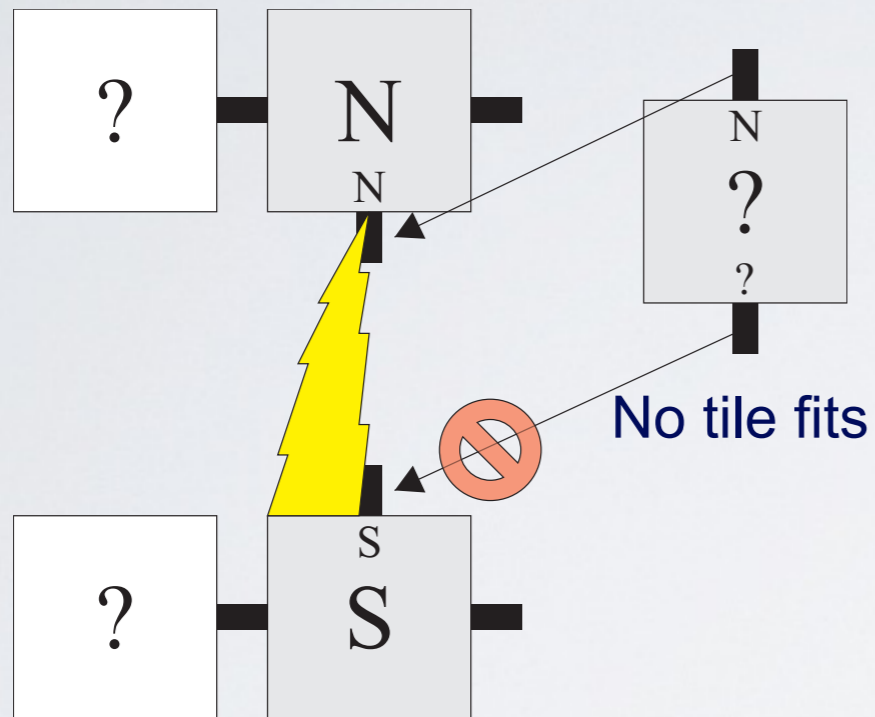

Better luck next time!

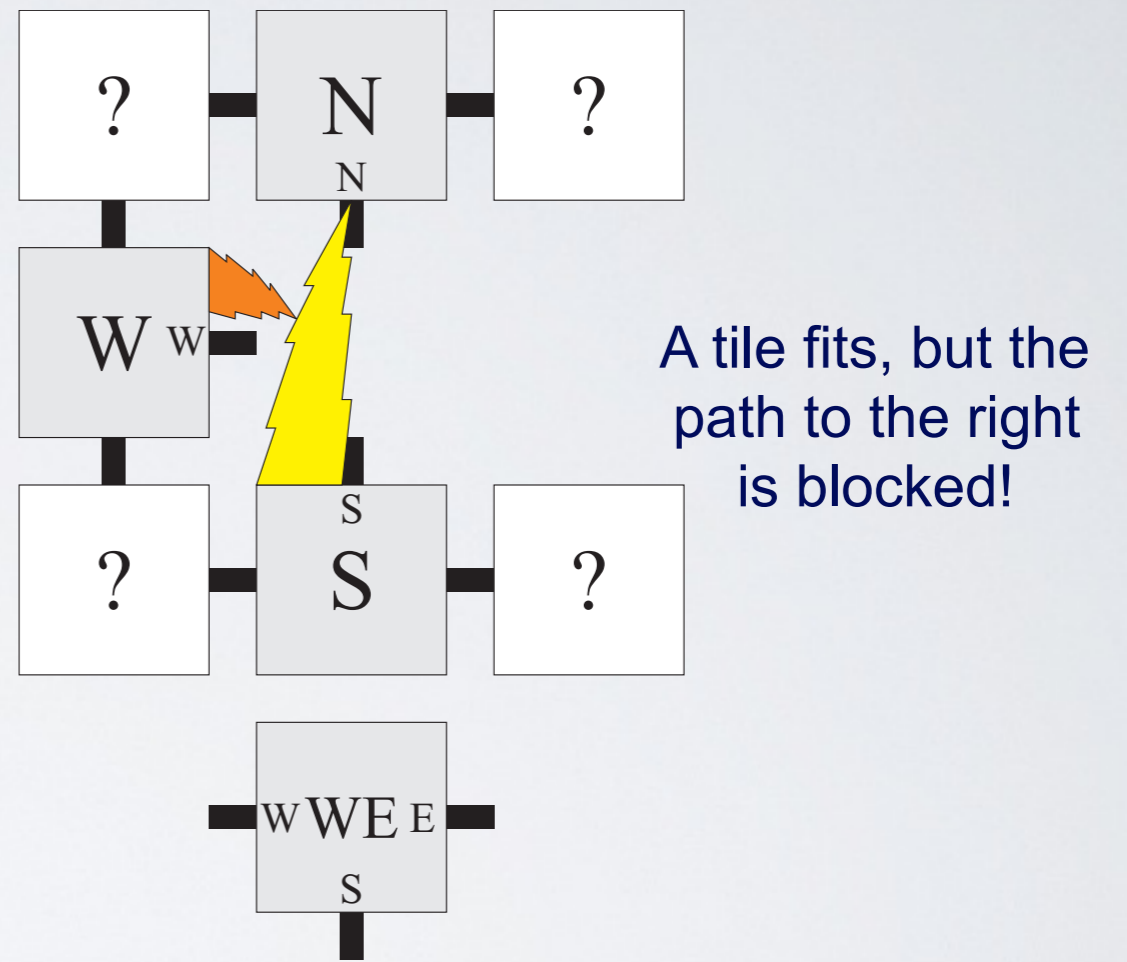

Uh oh!

Two-sided binding with opposite cooperating supersides

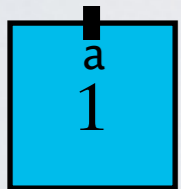
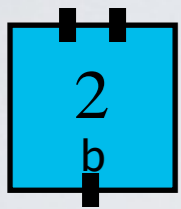
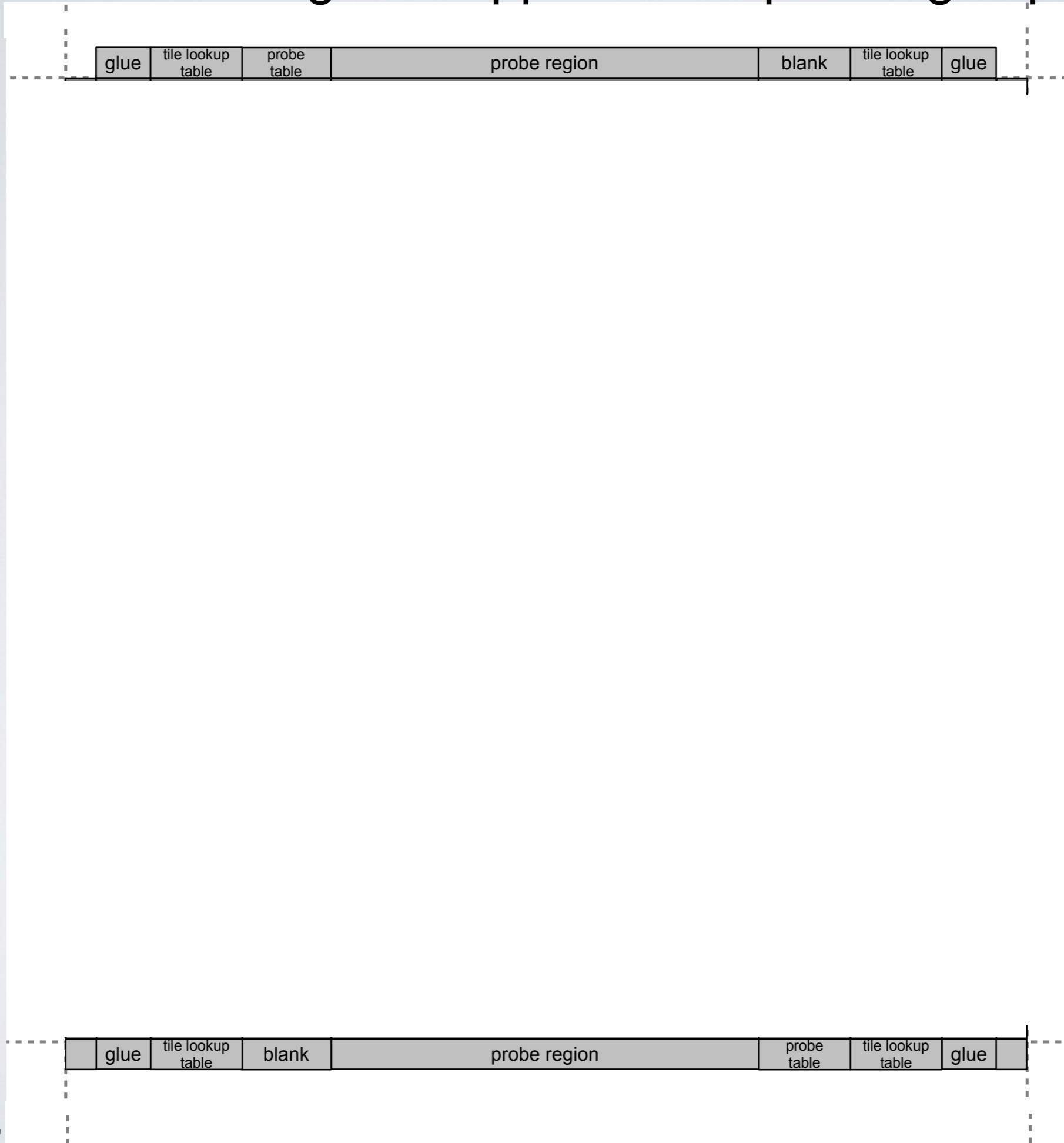

Two-sided binding with opposite cooperating supersides

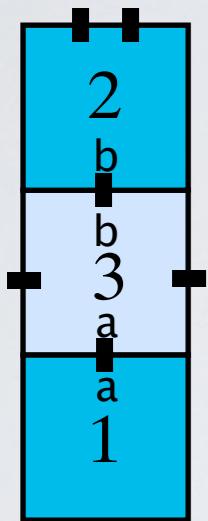
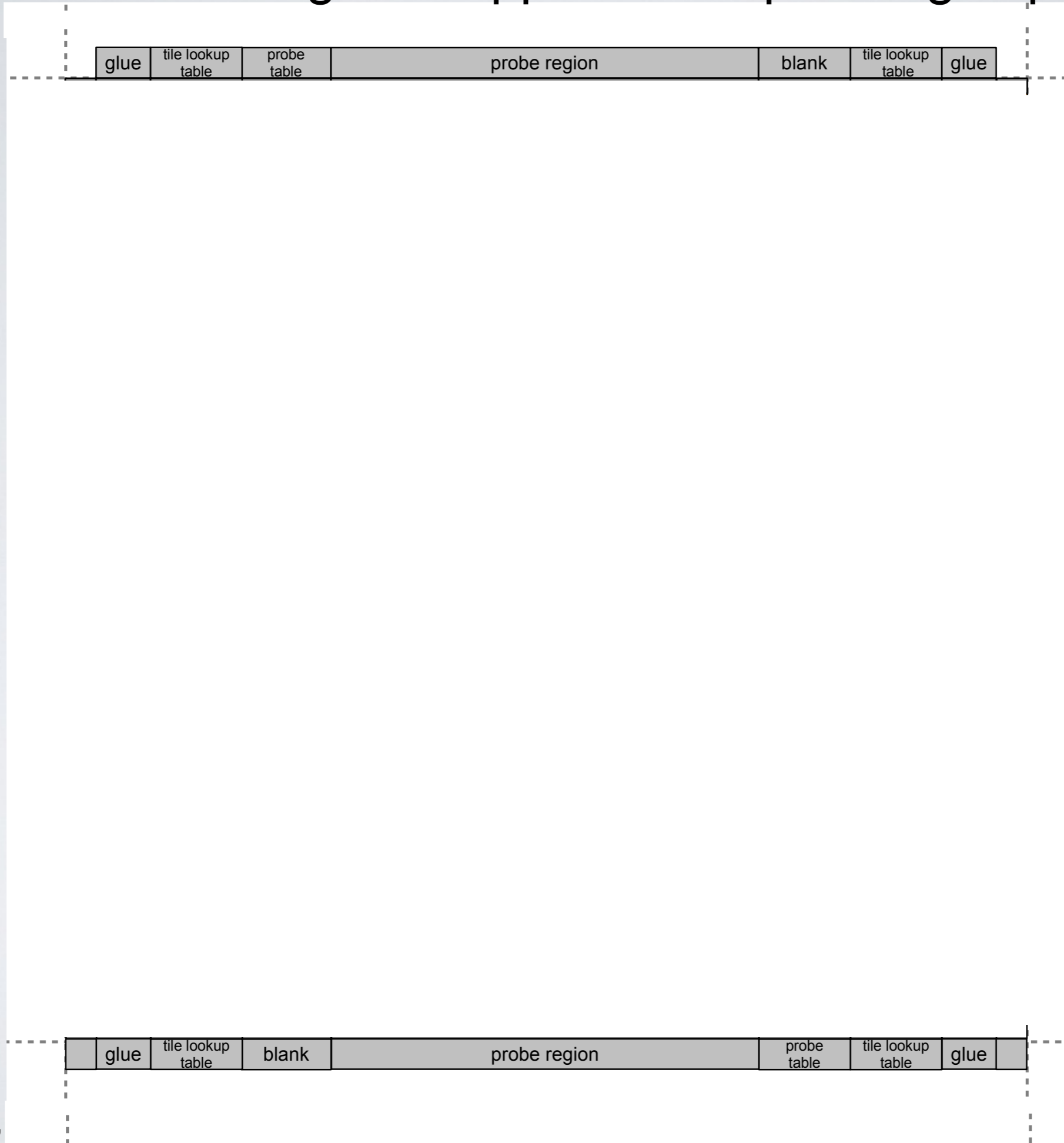

Two-sided binding with opposite cooperating supersides

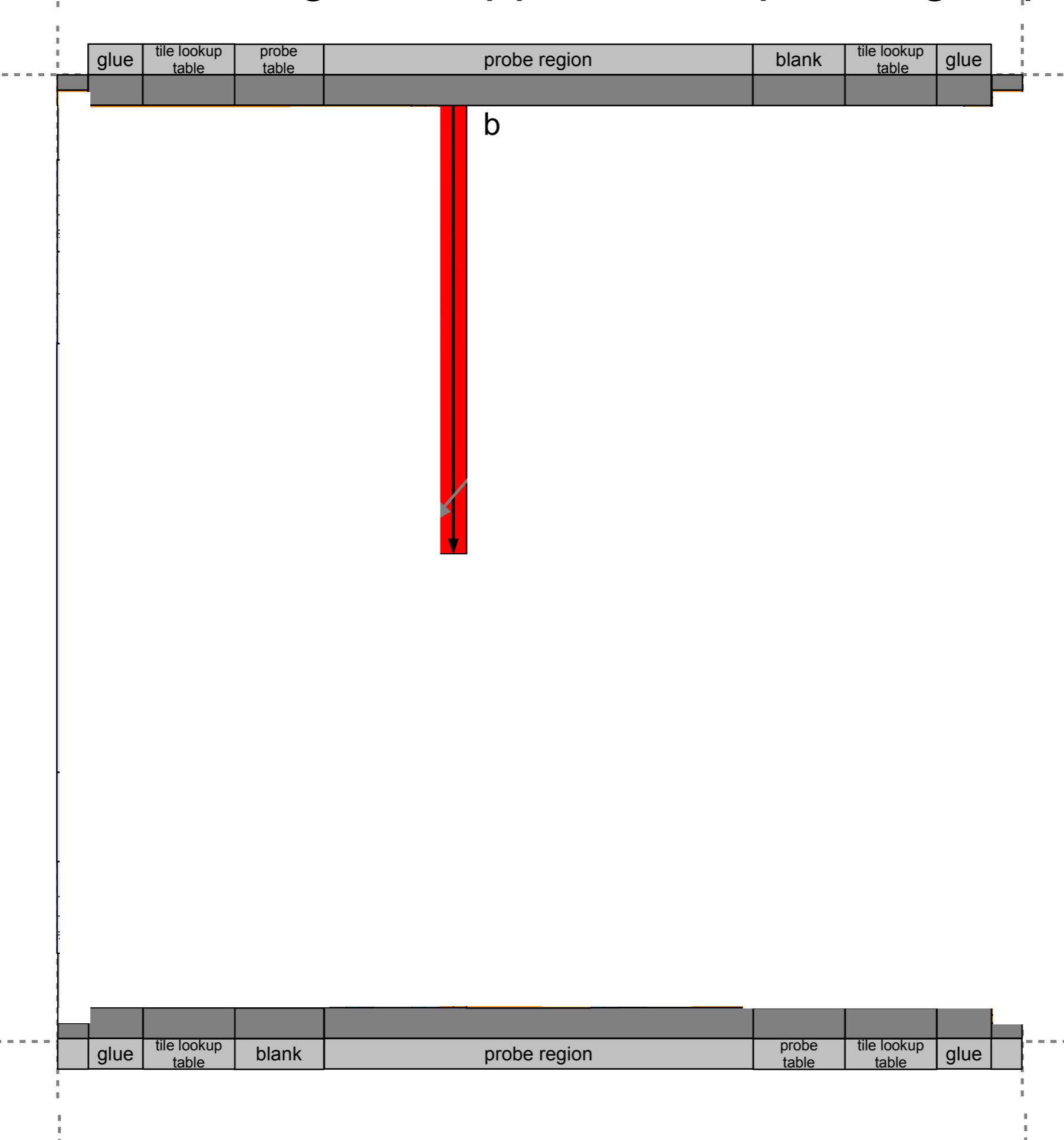
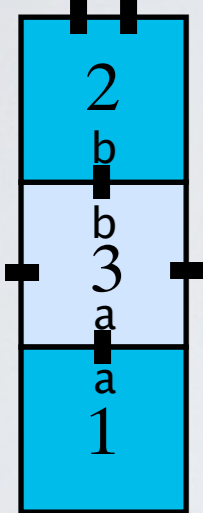

Two-sided binding with opposite cooperating supersides

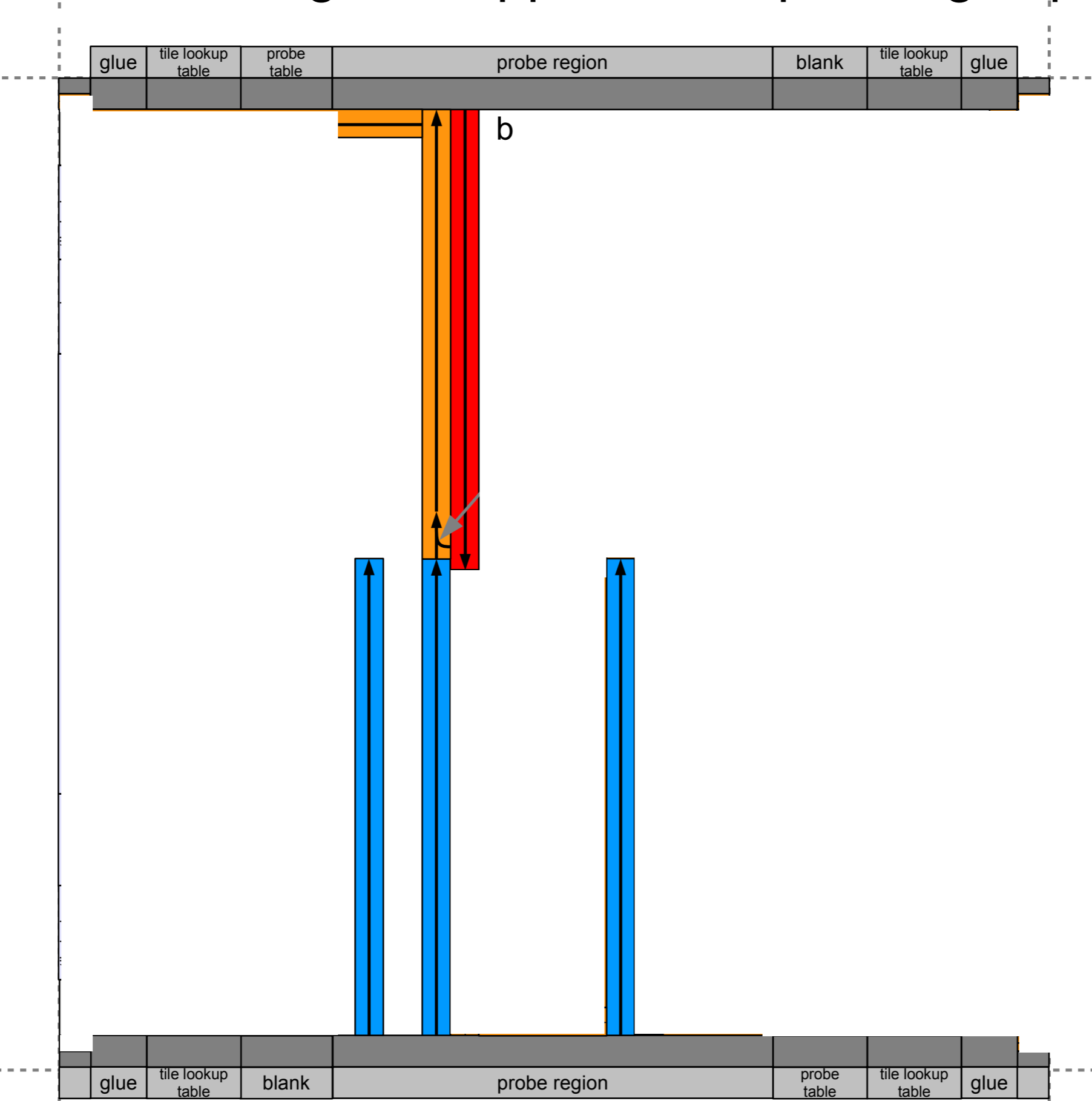
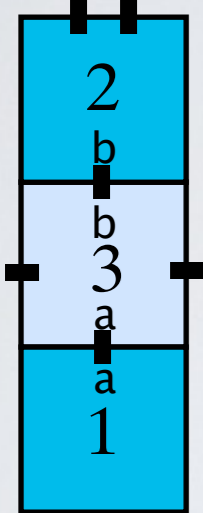

Two-sided binding with opposite cooperating supersides

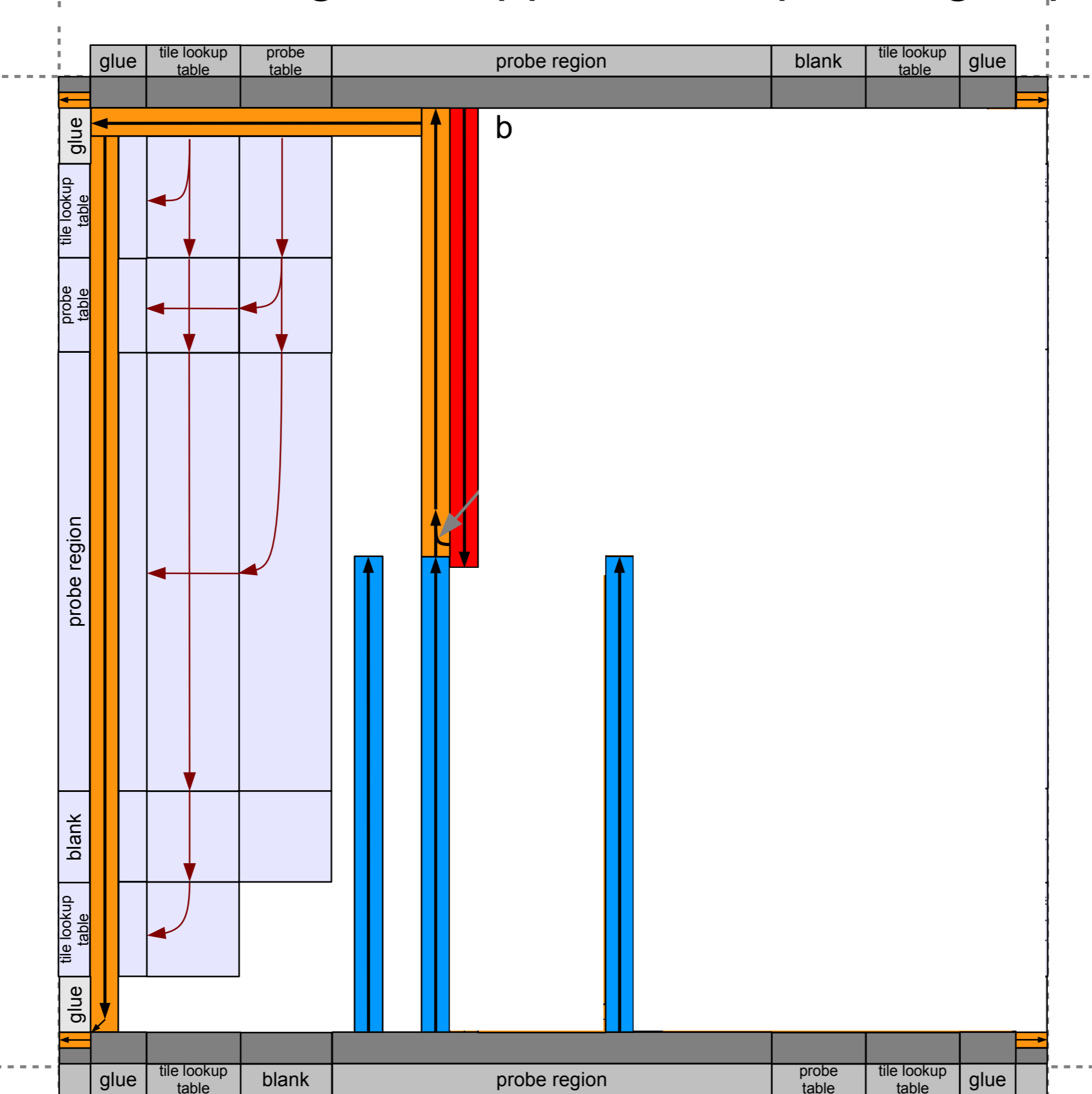
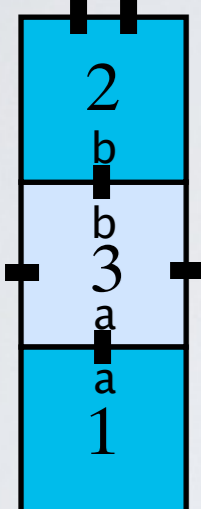

Two-sided binding with opposite cooperating supersides

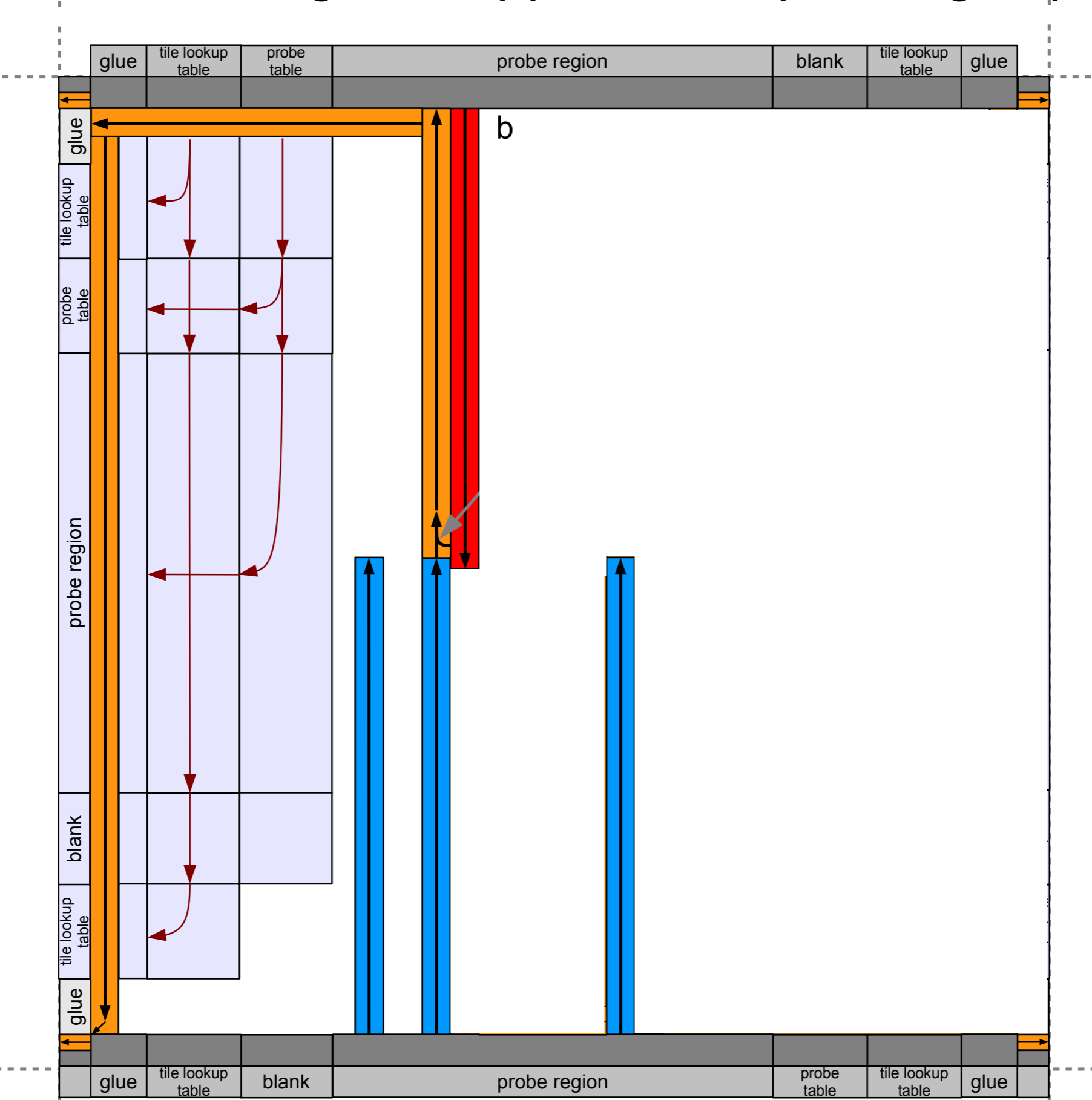
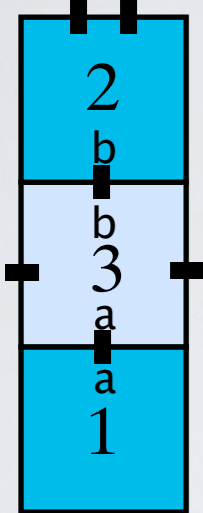

Two-sided binding with opposite cooperating supersides

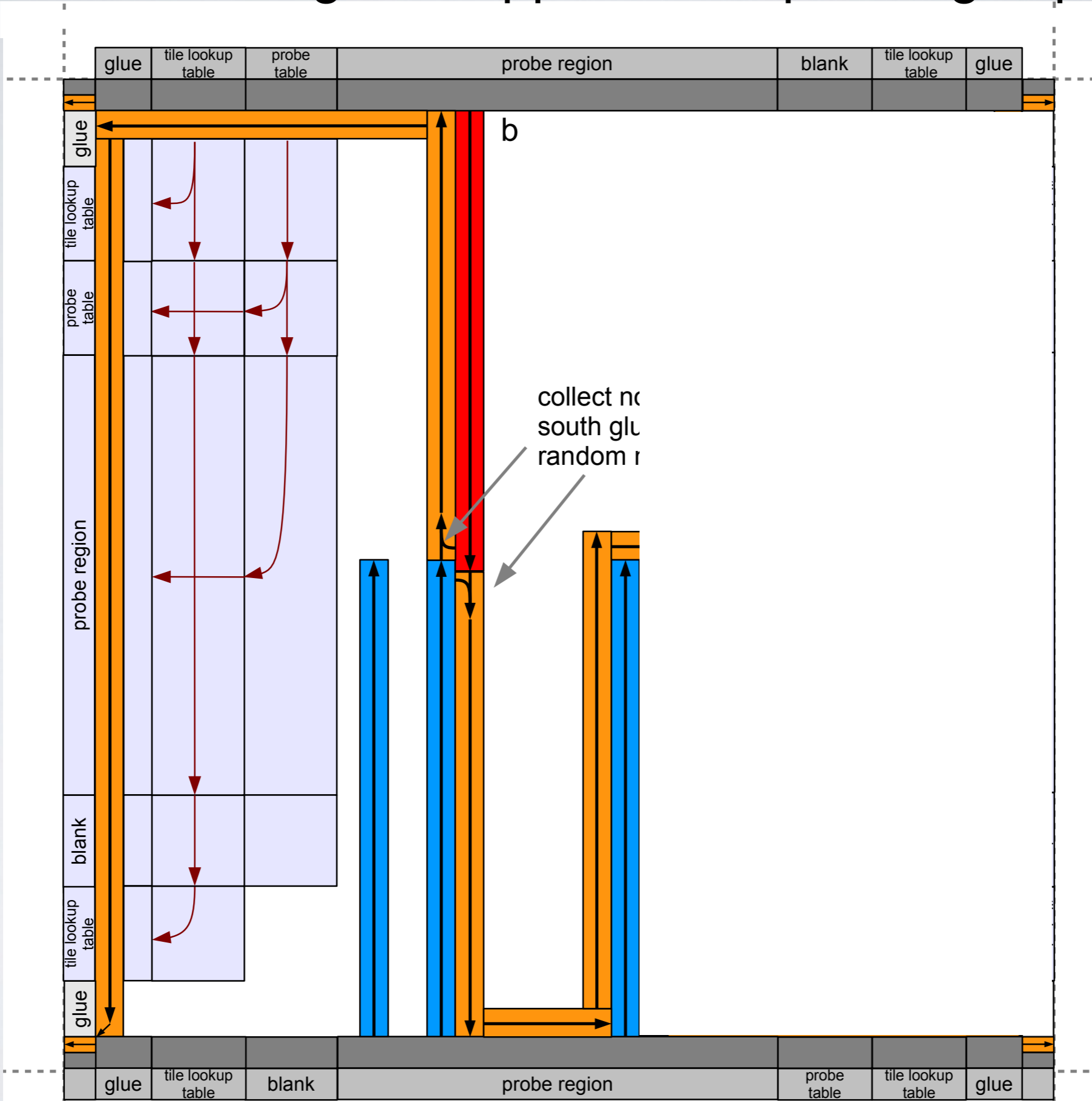
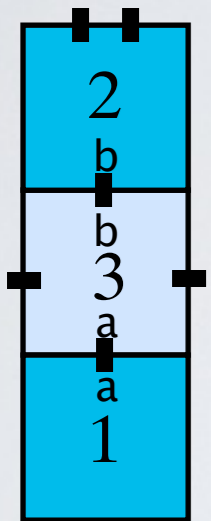

Two-sided binding with opposite cooperating supersides

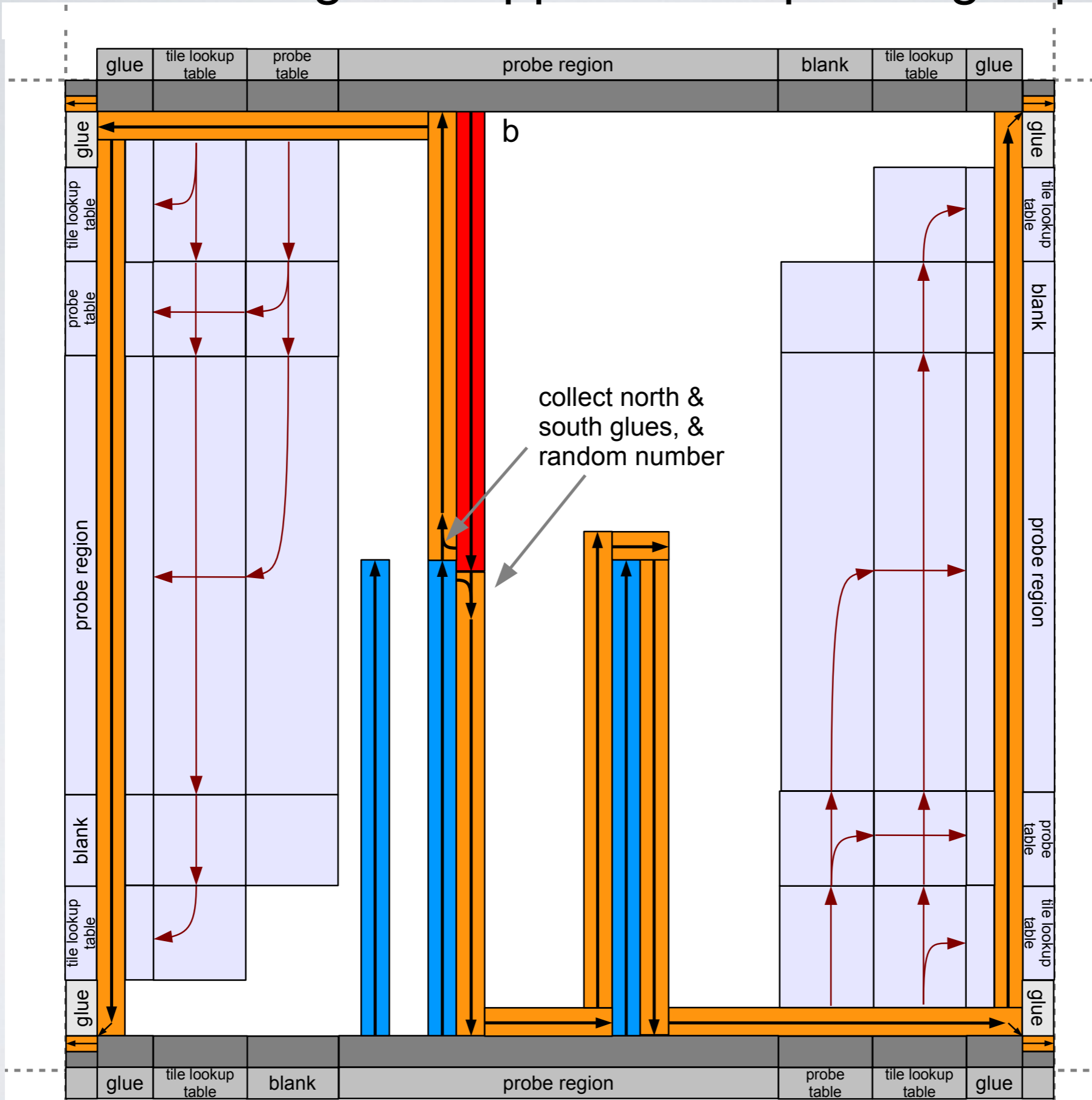
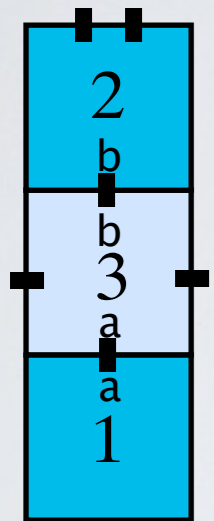

3-sided "uh-oh" example: probes miss each other

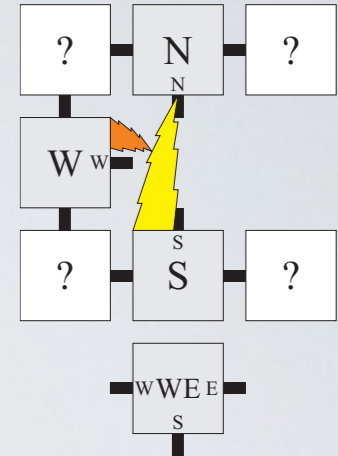
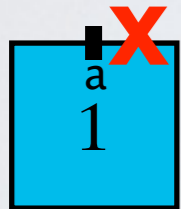
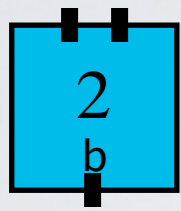
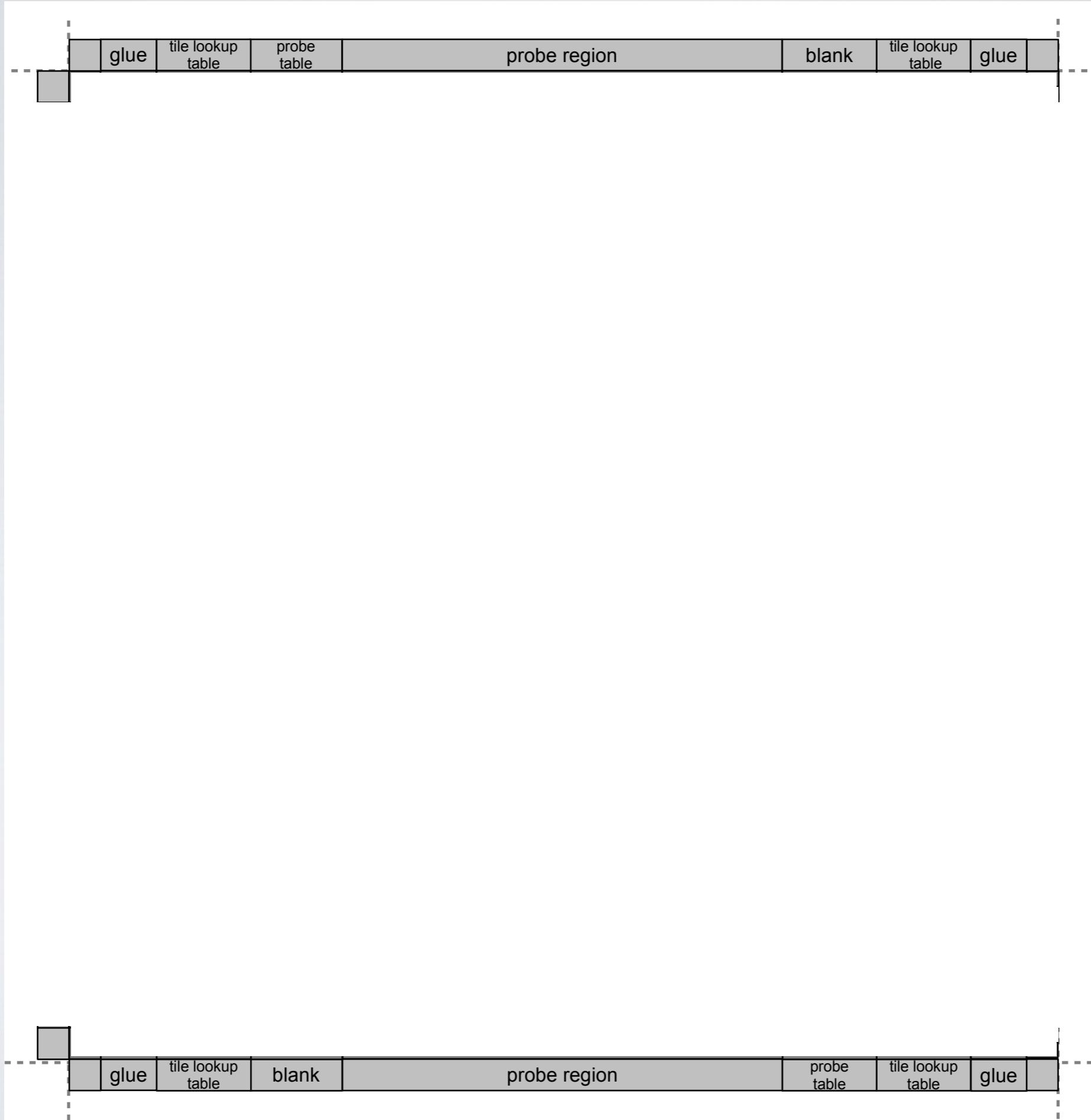

uh oh!

3-sided "uh-oh" example: probes miss each other

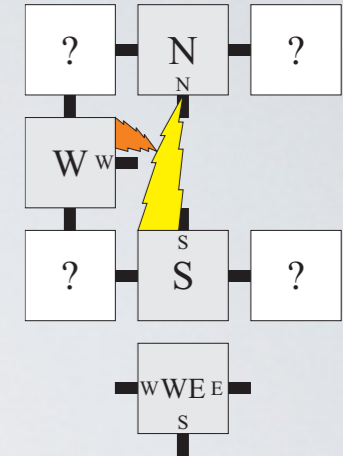
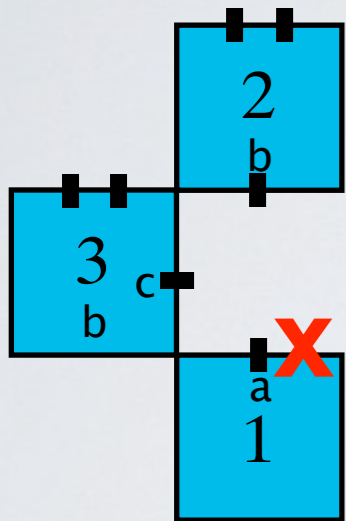
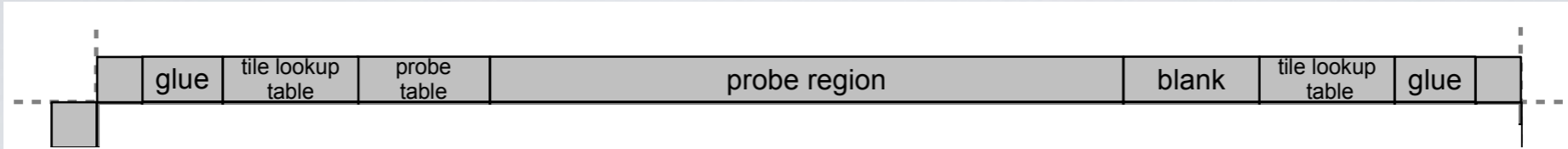

uh oh!

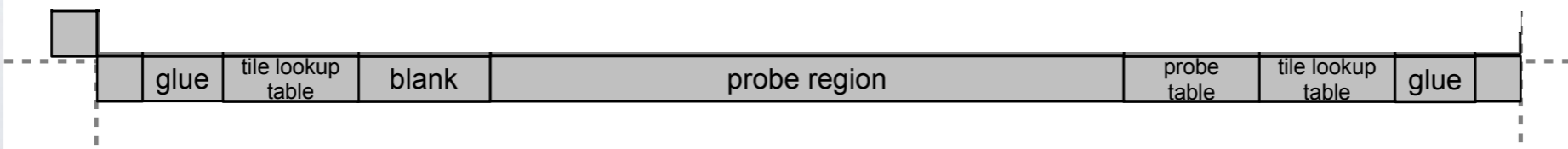

3-sided "uh-oh" example: probes miss each other

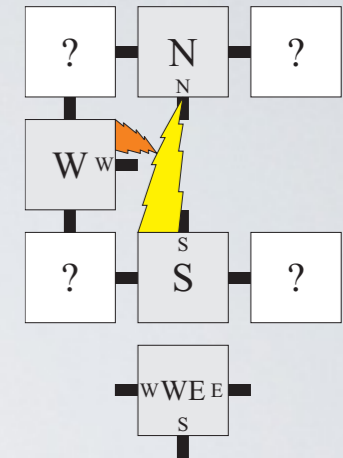
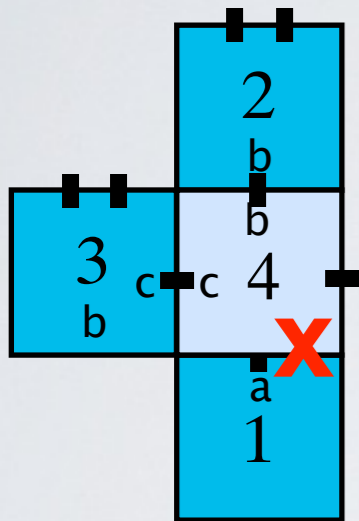
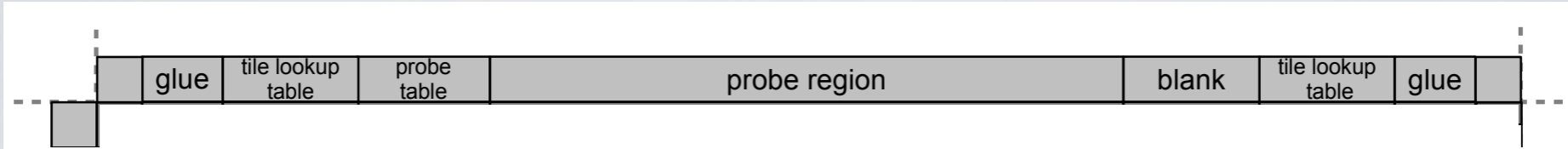

uh oh!

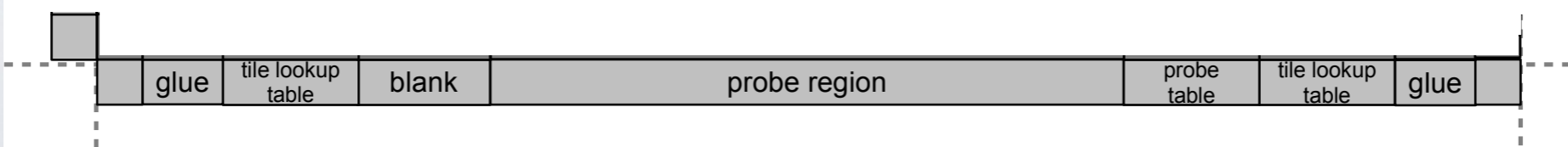

3-sided "uh-oh" example: probes miss each other

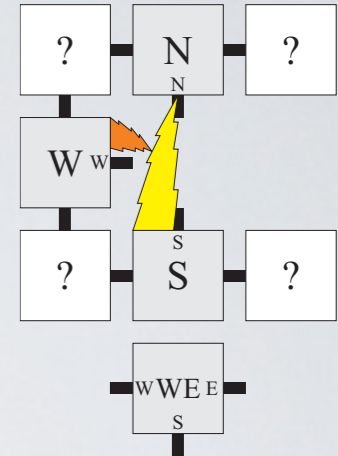
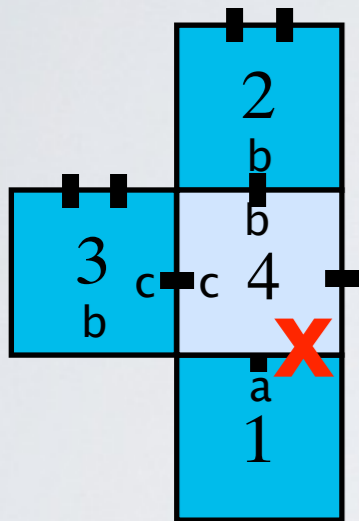
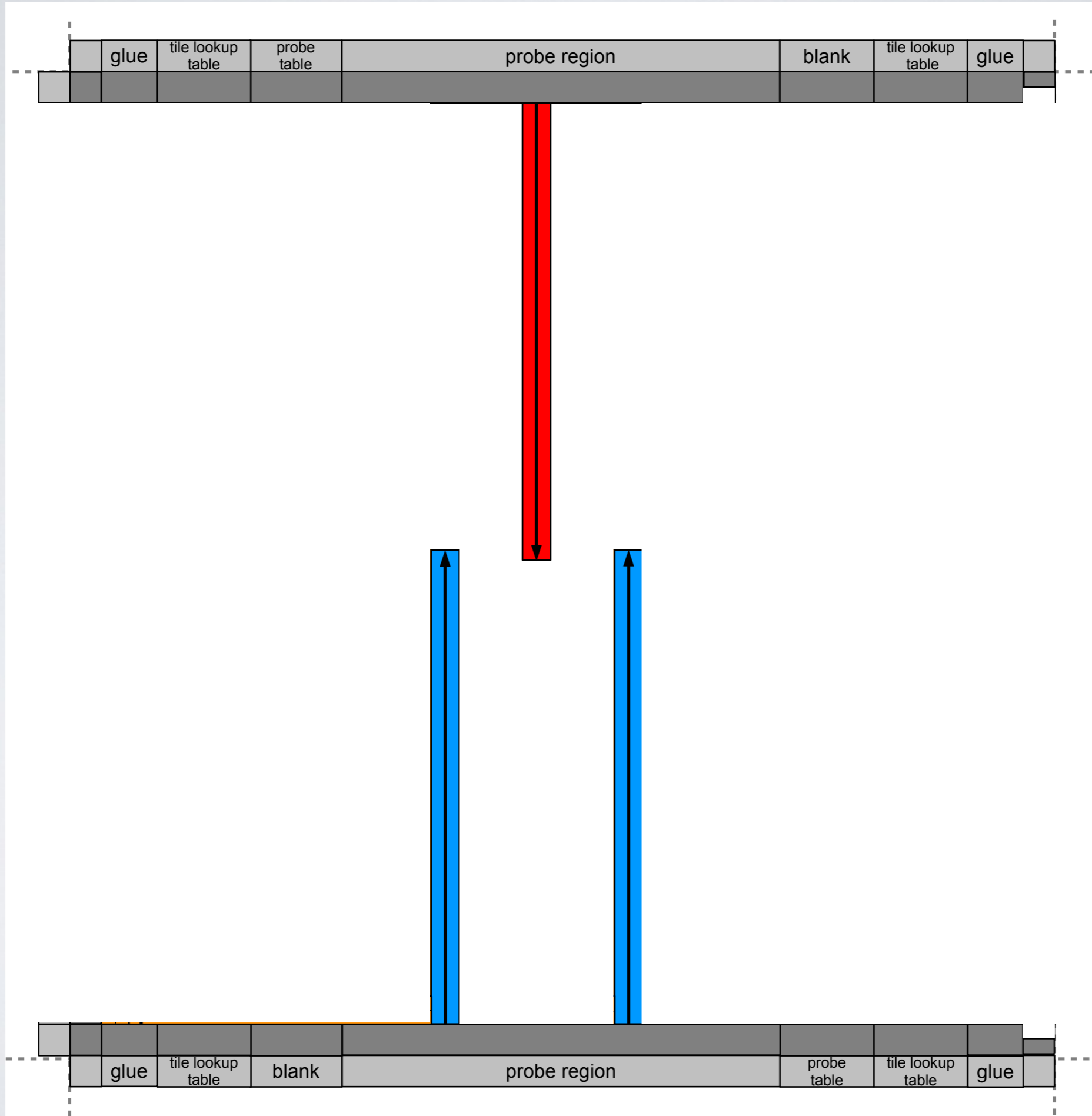

uh oh!

3-sided "uh-oh" example: probes miss each other

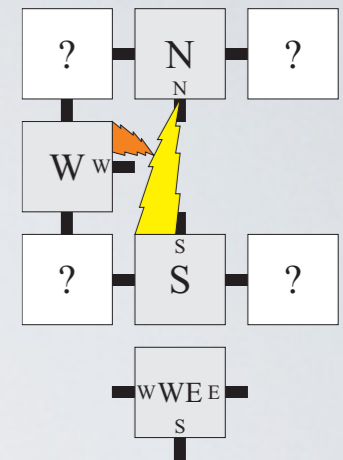
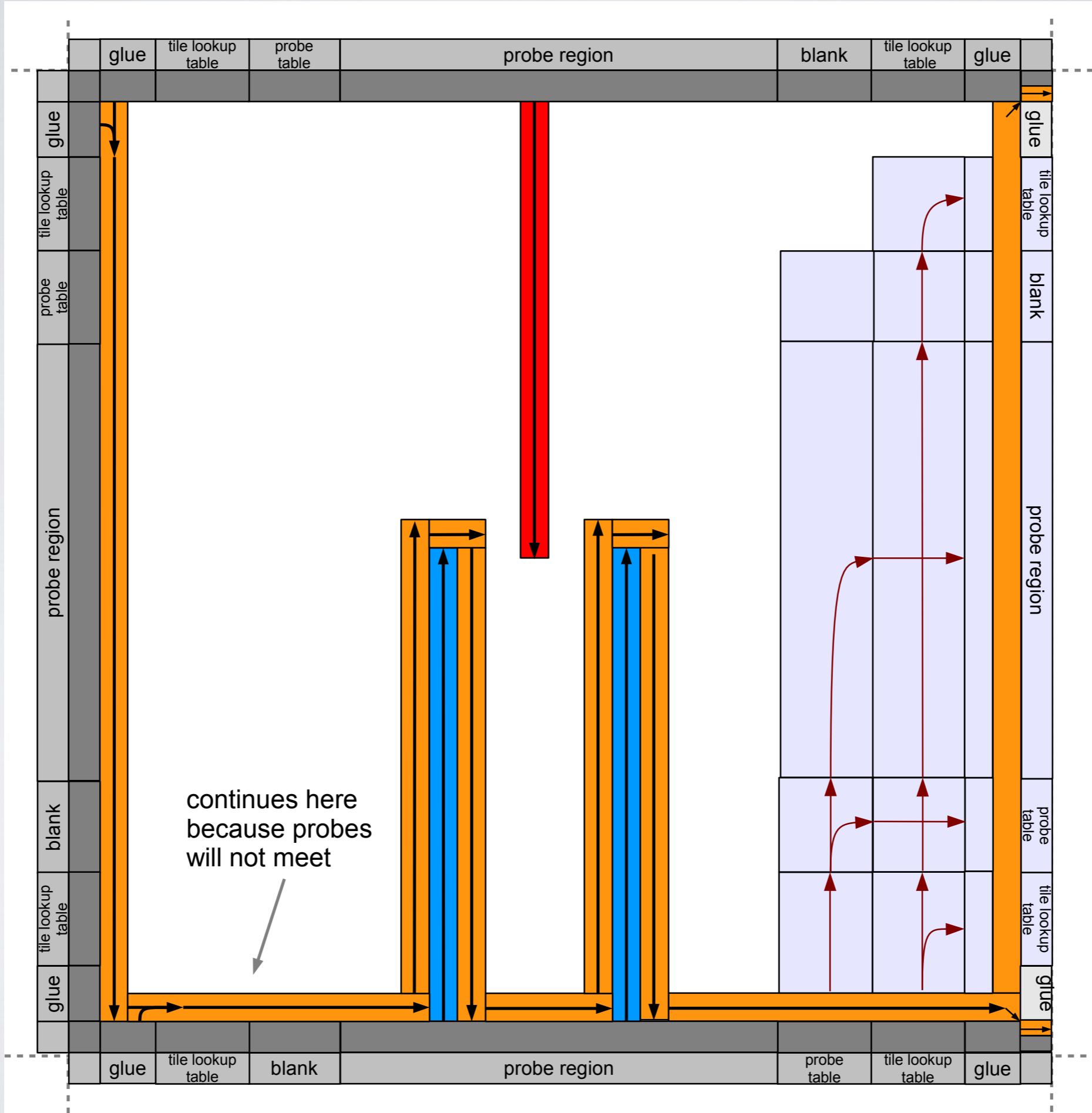
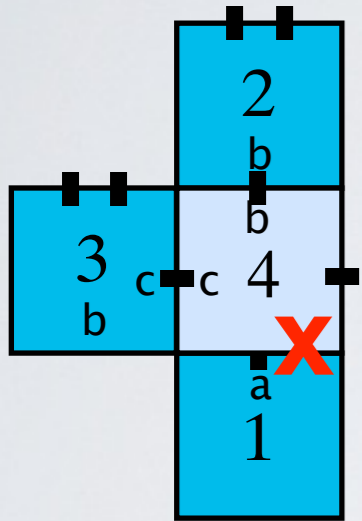

uh oh!

- Variety of cases for different orders of superside arrival
- Superside win/lose configurations and crawler initiation locations (green)
- Proof analogy:
 - Distributed game
 - Computation & geometry
 - Key challenge: make all the tricks work together

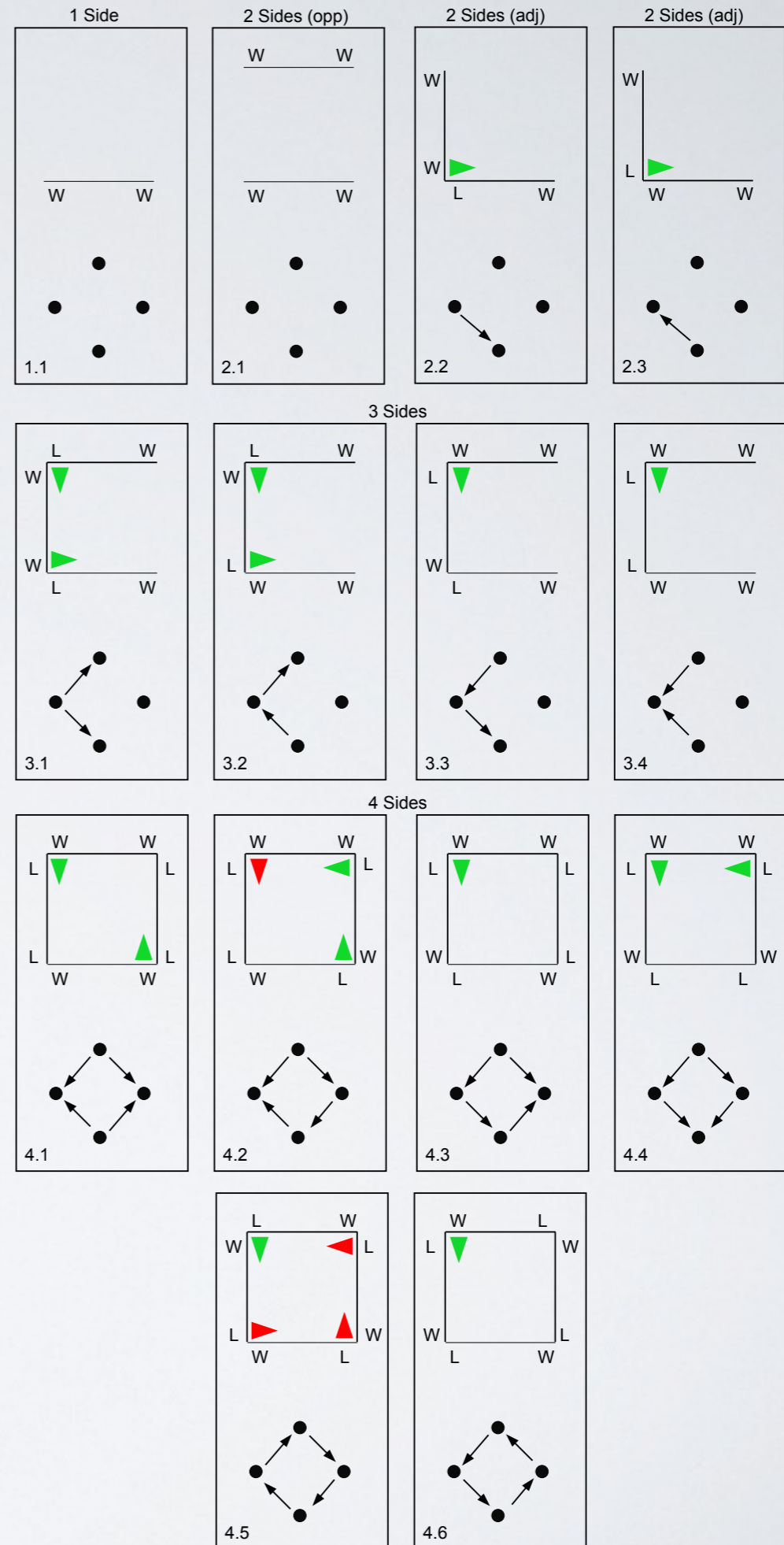

Is the abstract tile assembly model intrinsically universal?

Yes!

Theorem: There is a single universal tile set U that simulates *any* tile assembly system

Doty, Lutz, Patitz, Schweller, Summers, Woods. FOCS 2012

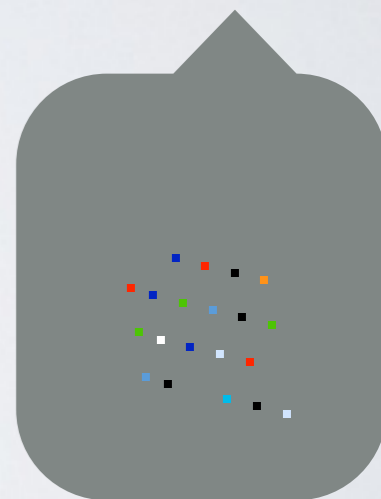

Temperature = 2

Universal
tile set

Our journey



aTAM, $\tau \geq 2$ (IU [11])

Magic dust

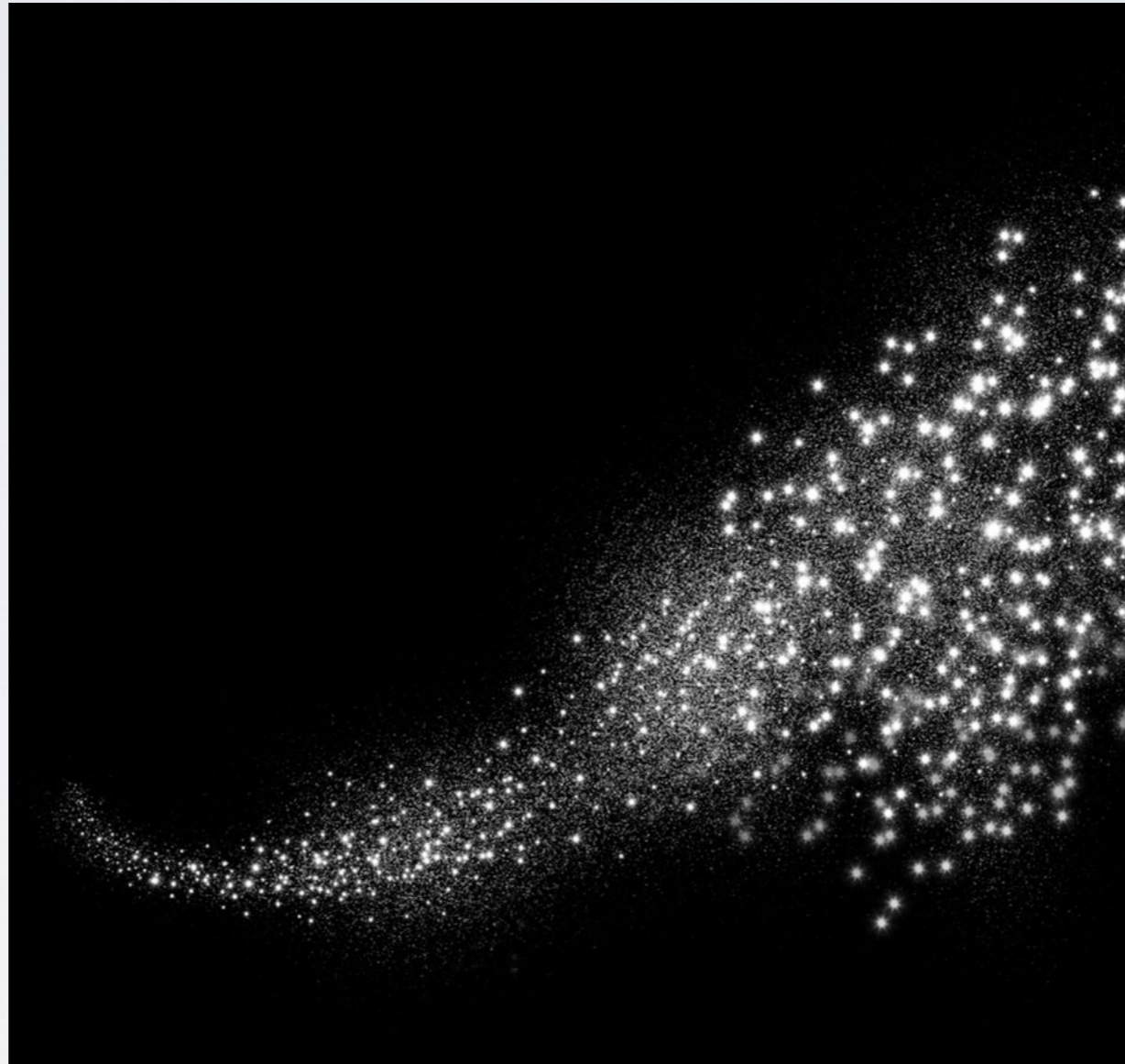

<http://nighthawk101stock.deviantart.com/>

Result: There is a **single** rotatable polygon that simulates **all** tile assembly systems



Result: For each (Wang) plane tile system there is one rotatable polygon that simulates it

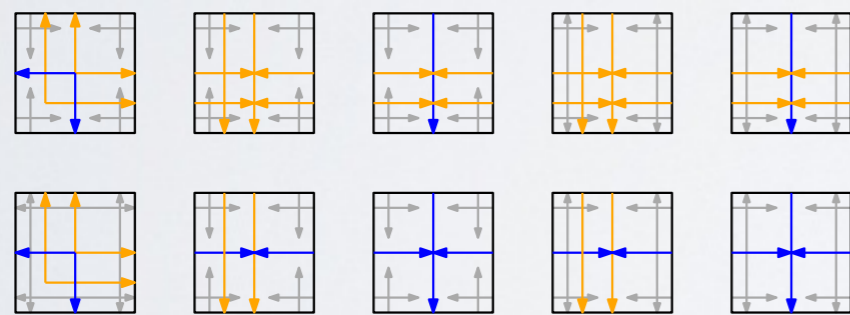

Robinson's 10-tile aperiodic tile set

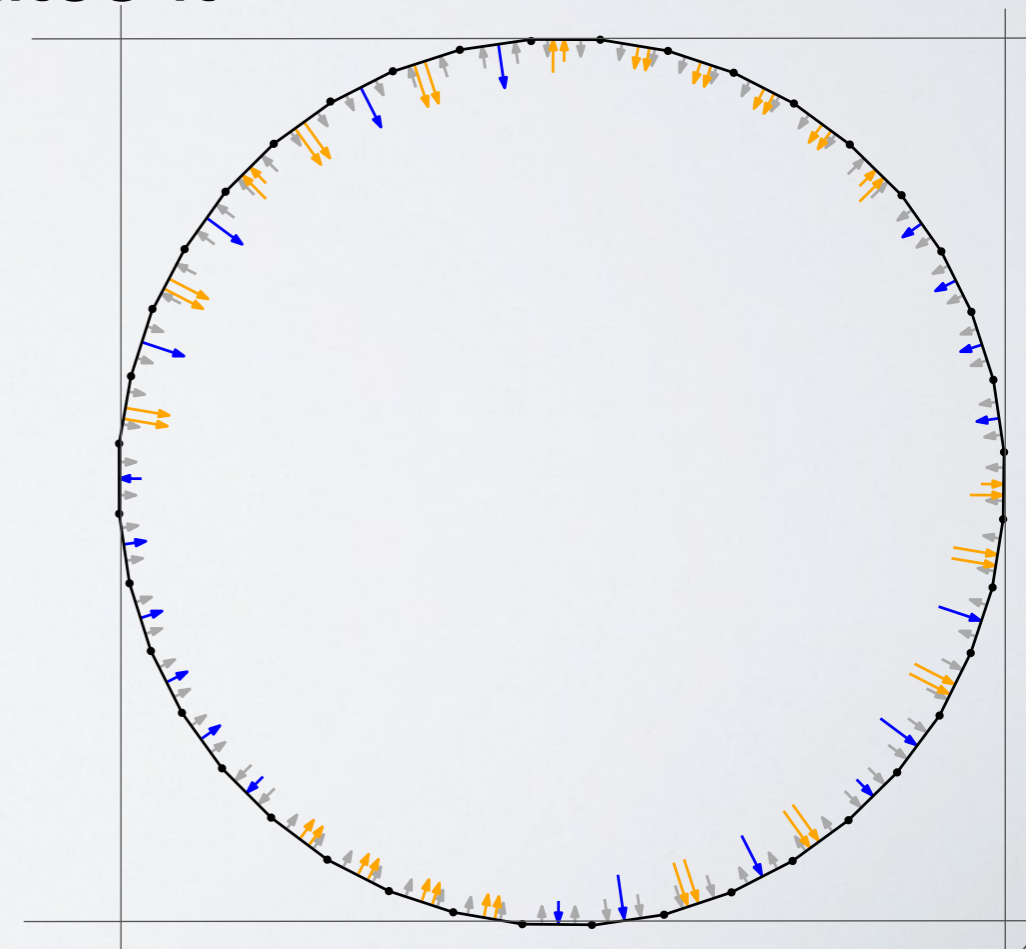

Demaine, Demaine, Fekete, Patitz, Schweller, Winslow, Woods. One Tile to Rule Them All: Simulating Any Turing Machine, Tile Assembly System, or Tiling System with One Rotatable Puzzle Piece. ICALP 2014.

Theorem: For each (Wang) plane tiling system there is one rotatable polygon that simulates it

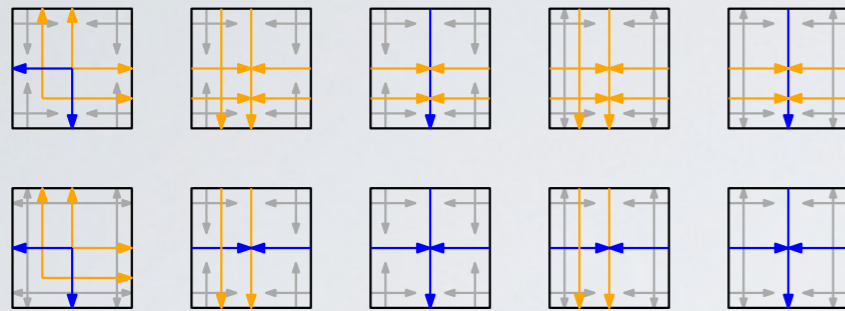

Robinson's 10-tile aperiodic tile set

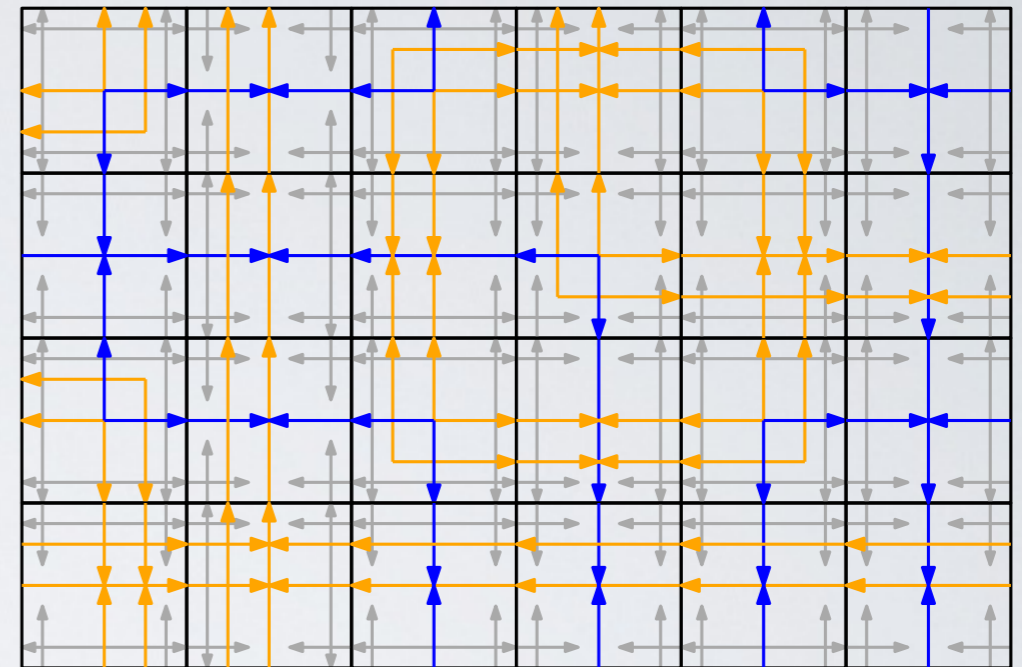

Portion of a tiling of Robinson's 10-tile aperiodic square tile set (with rotations)

- Wang plane tiling system:
 - Try to fill the plane with tiles.
 - All sides must match.
 - We care about the existence of tilings, but not how we made the tiling

Demaine, Demaine, Fekete, Patitz, Schweller, Winslow, Woods.
One Tile to Rule Them All: Simulating Any Turing Machine, Tile
Assembly System, or Tiling System with One Rotatable Puzzle
Piece. ICALP 2014.

A rotatable polygon that simulates a tile set

- For each set of (possibly rotatable, flipable) Wang square/hexagon tiles there is a single rotatable tile that simulates it

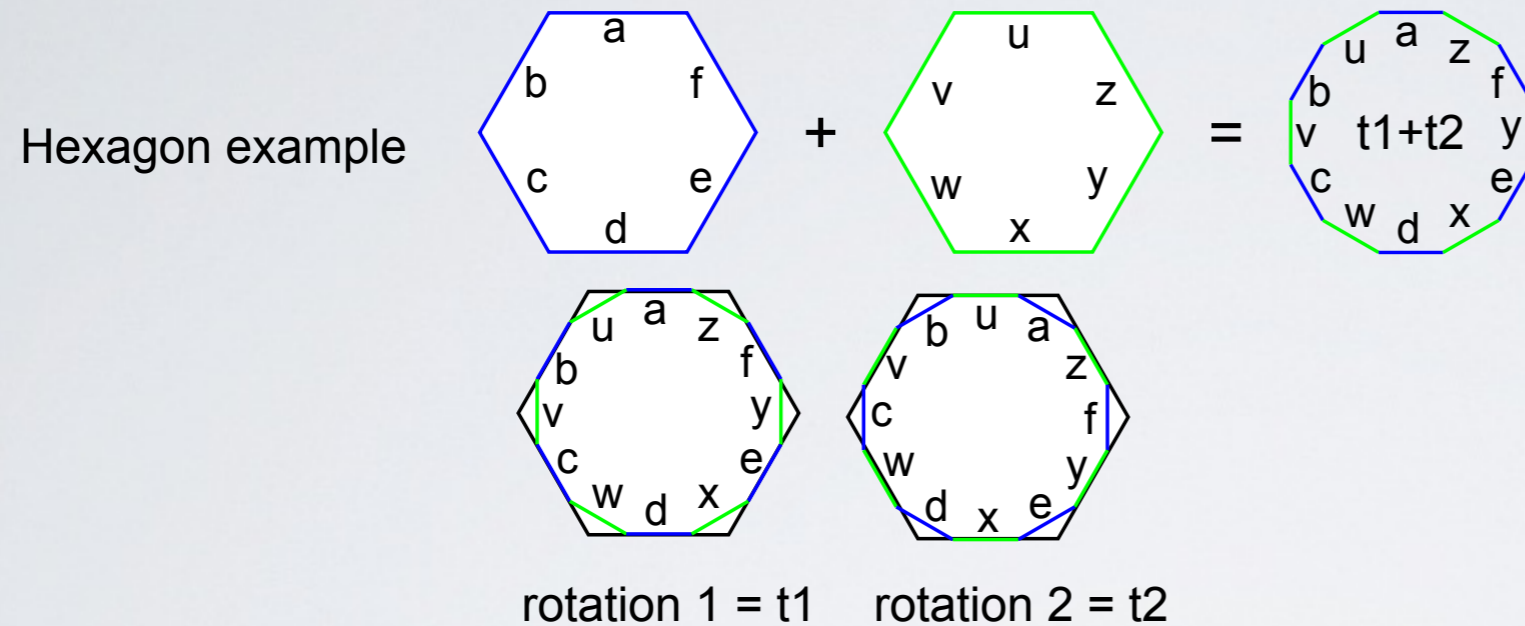

A rotatable polygon that simulates a tile set

- For each set of (possibly rotatable, flipable) Wang square/hexagon tiles there is a single rotatable tile that simulates it

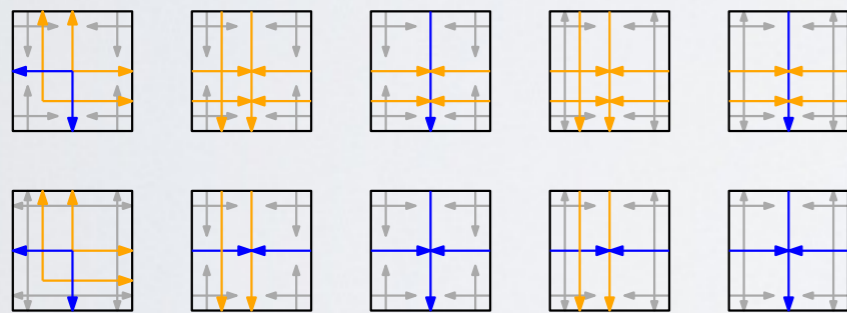
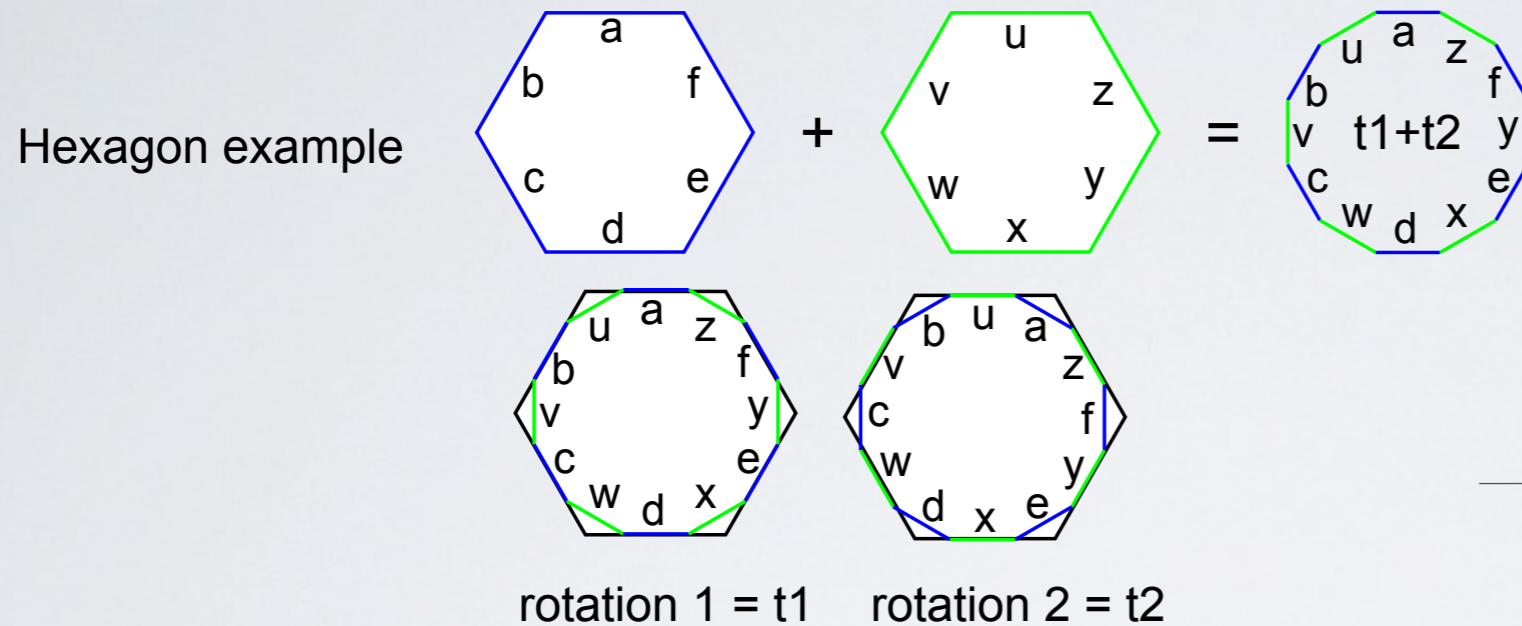

Robinson's 10-tile aperiodic tile set
(complimentary matching constraint)

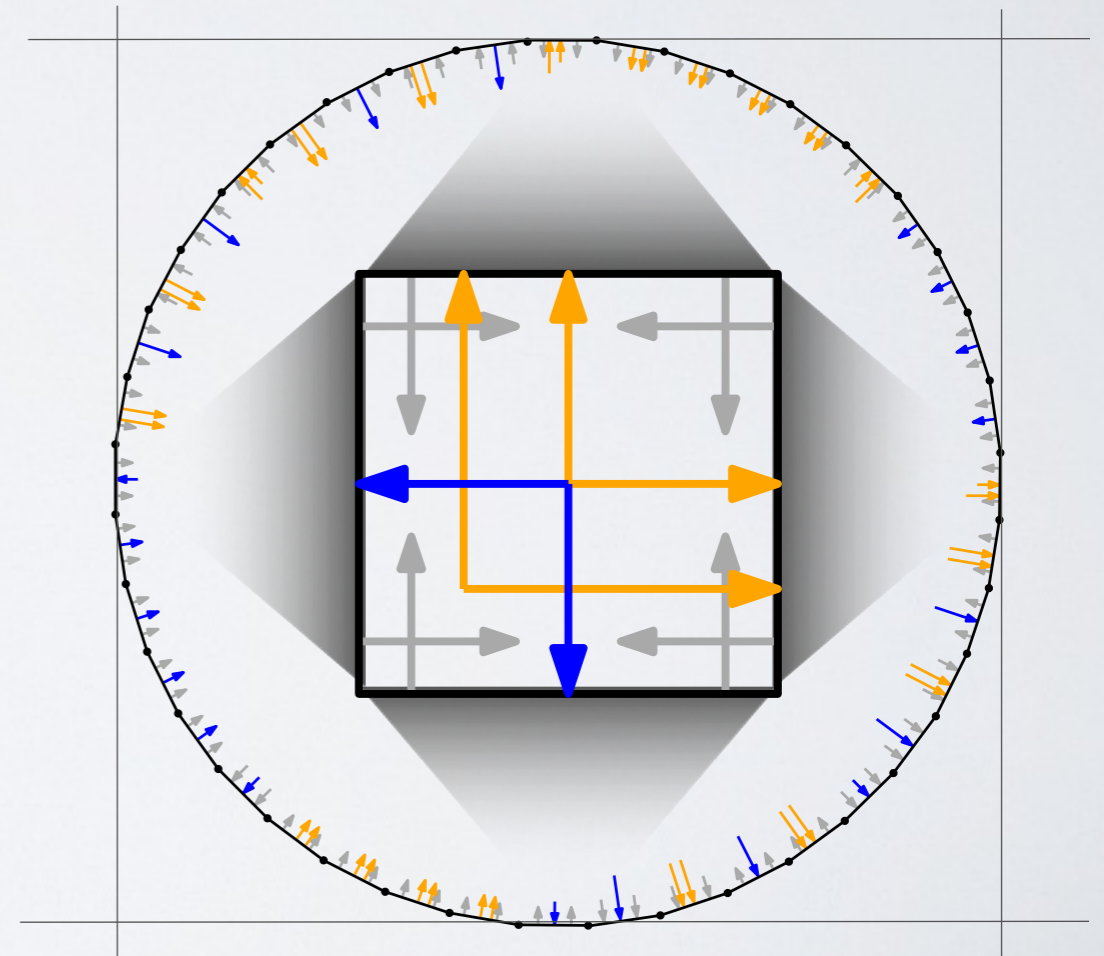

A rotatable polygon that simulates a tile set

- For each set of (possibly rotatable, and/or flipable) square or hexagon tiles there is a single (rotatable, flipable) tile that simulates it

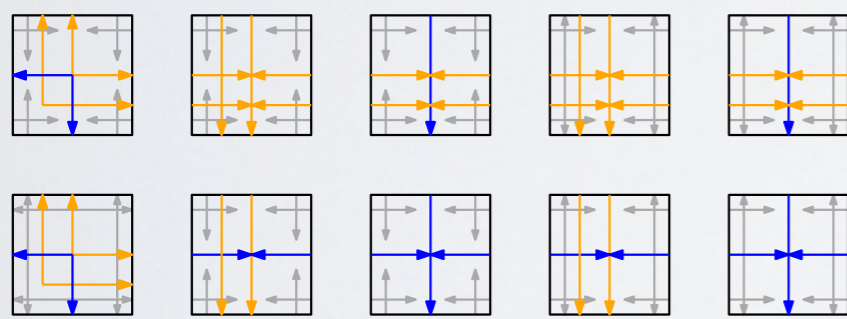
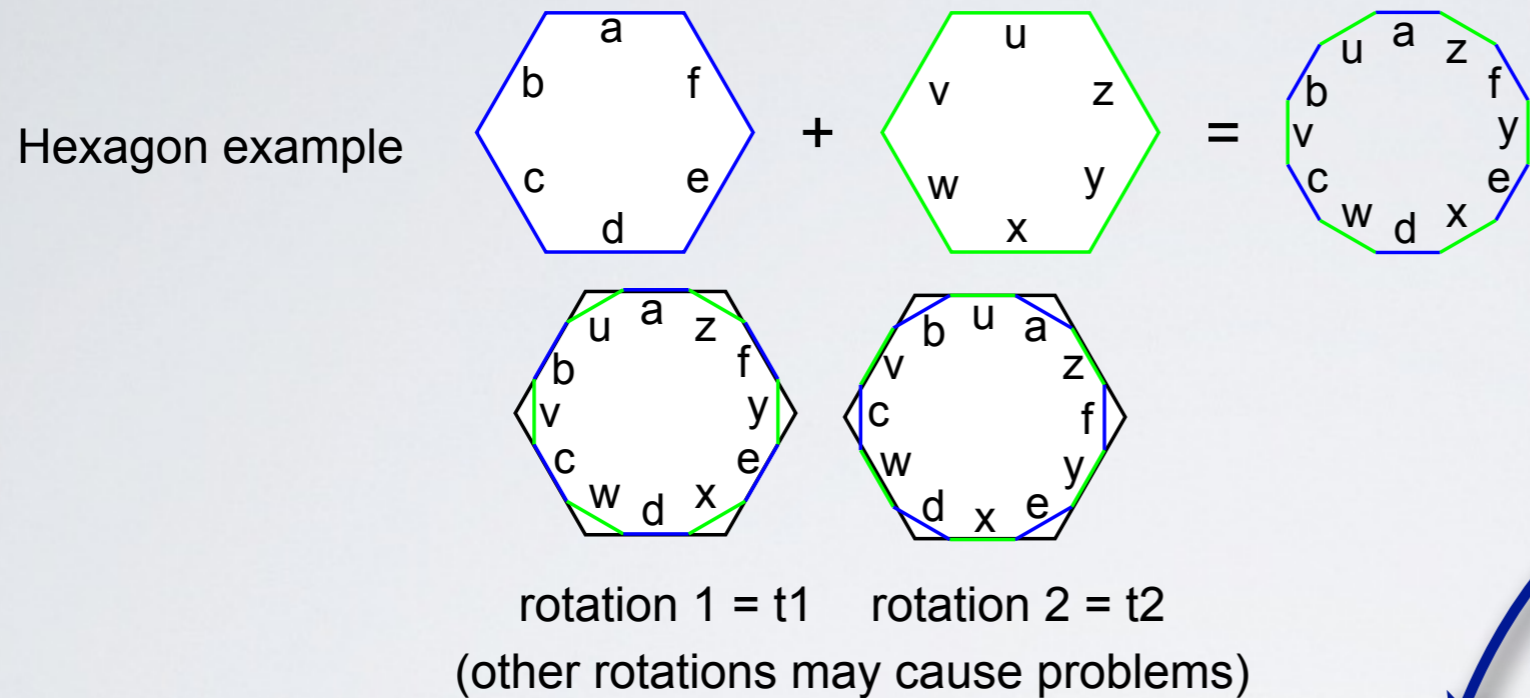

Robinson's 10-tile aperiodic tile set
(complimentary matching constraint)

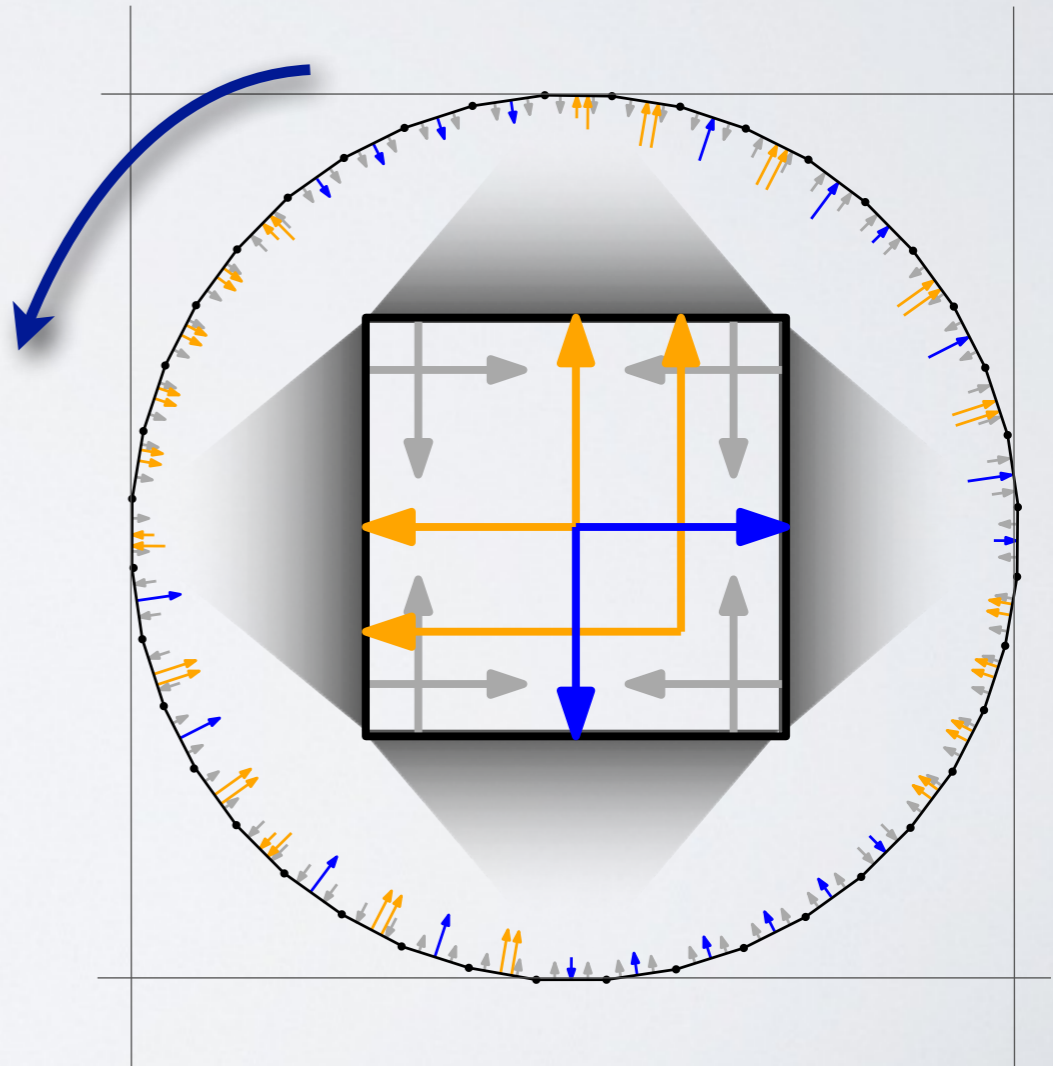

1

- An aperiodic tile set with 1 tile!
- Small gaps (< 1 tile in size) in the tilings
- We have given a general method (a compiler) to convert any square/hexagon plane tiling tile set to a single tile that simulates it
- So we can have a single tile that is aperiodic, or a single tile that simulates a universal Turing machine, etc.

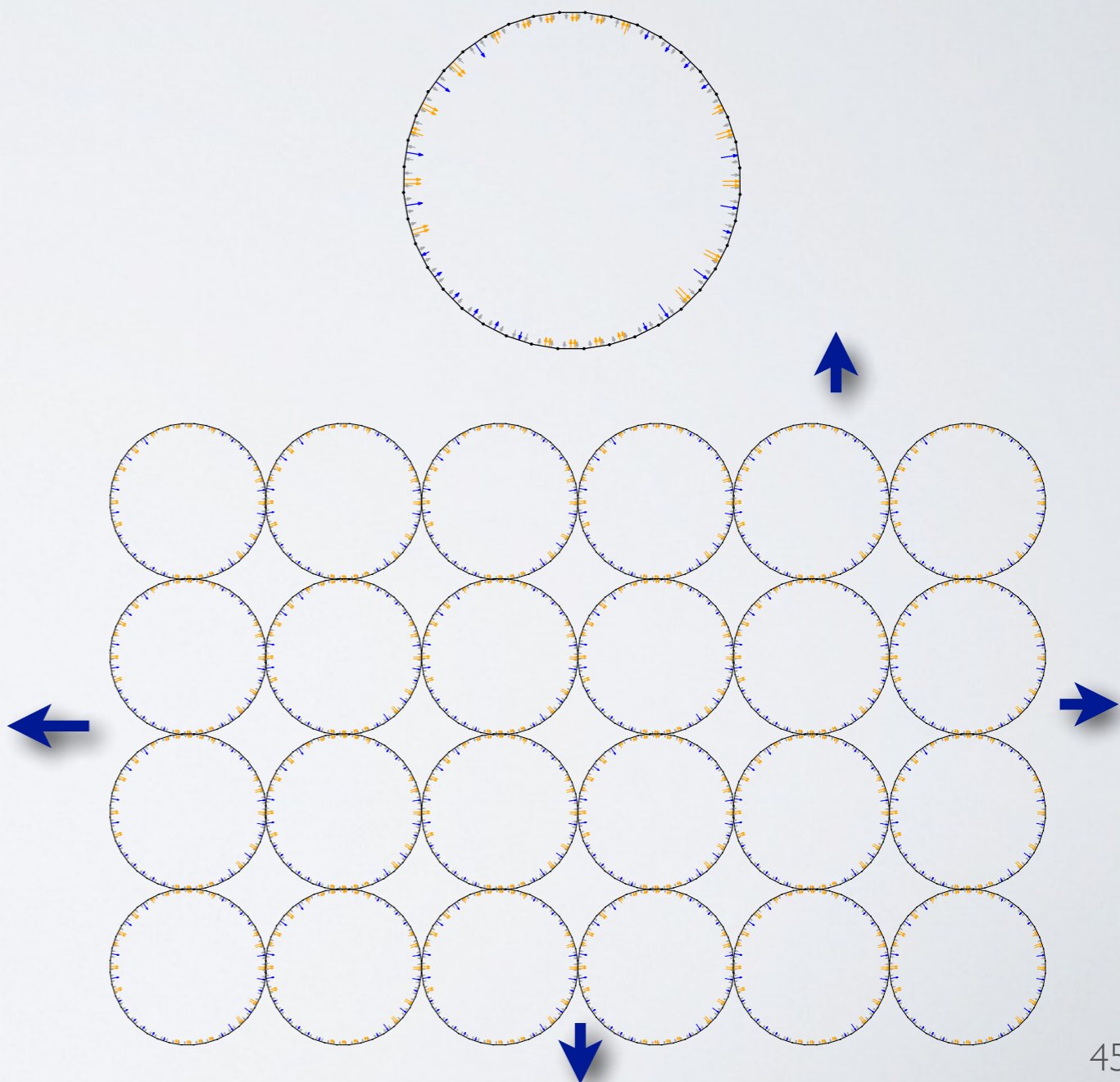
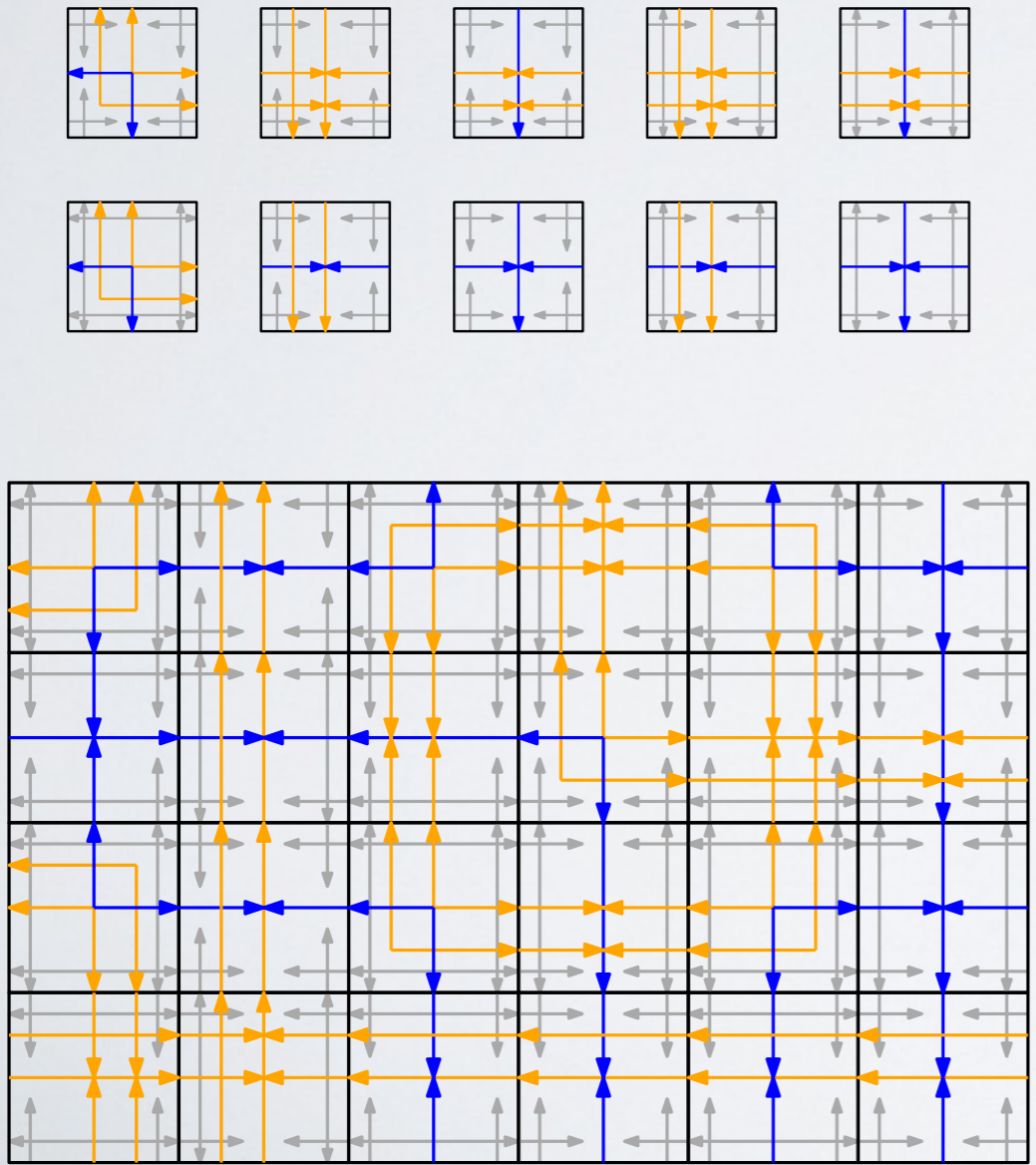

1 aperiodic tile

- An aperiodic tile set with 1 tile!
- Small gaps in the tilings
- We have given a general method (a compiler) to convert any square/hexagon plane tiling tile set to a single tile that simulates it
- So we can have a single tile that is aperiodic, or a single tile that simulates a universal Turing machine, etc.

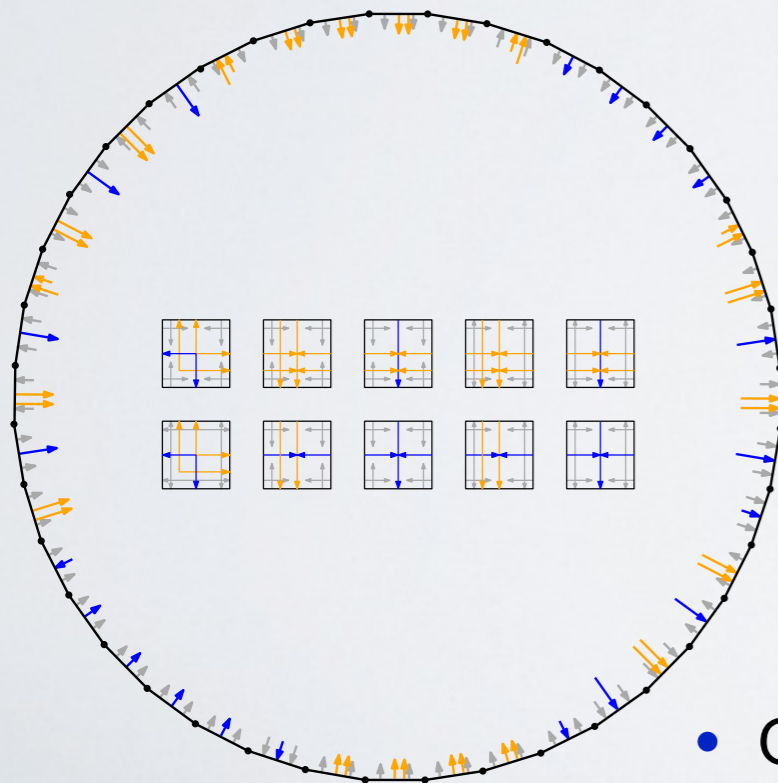

1 aperiodic tile

- Socolar–Taylor disconnected tile. 2012
- All of its tilings are aperiodic
- Rotations + flips

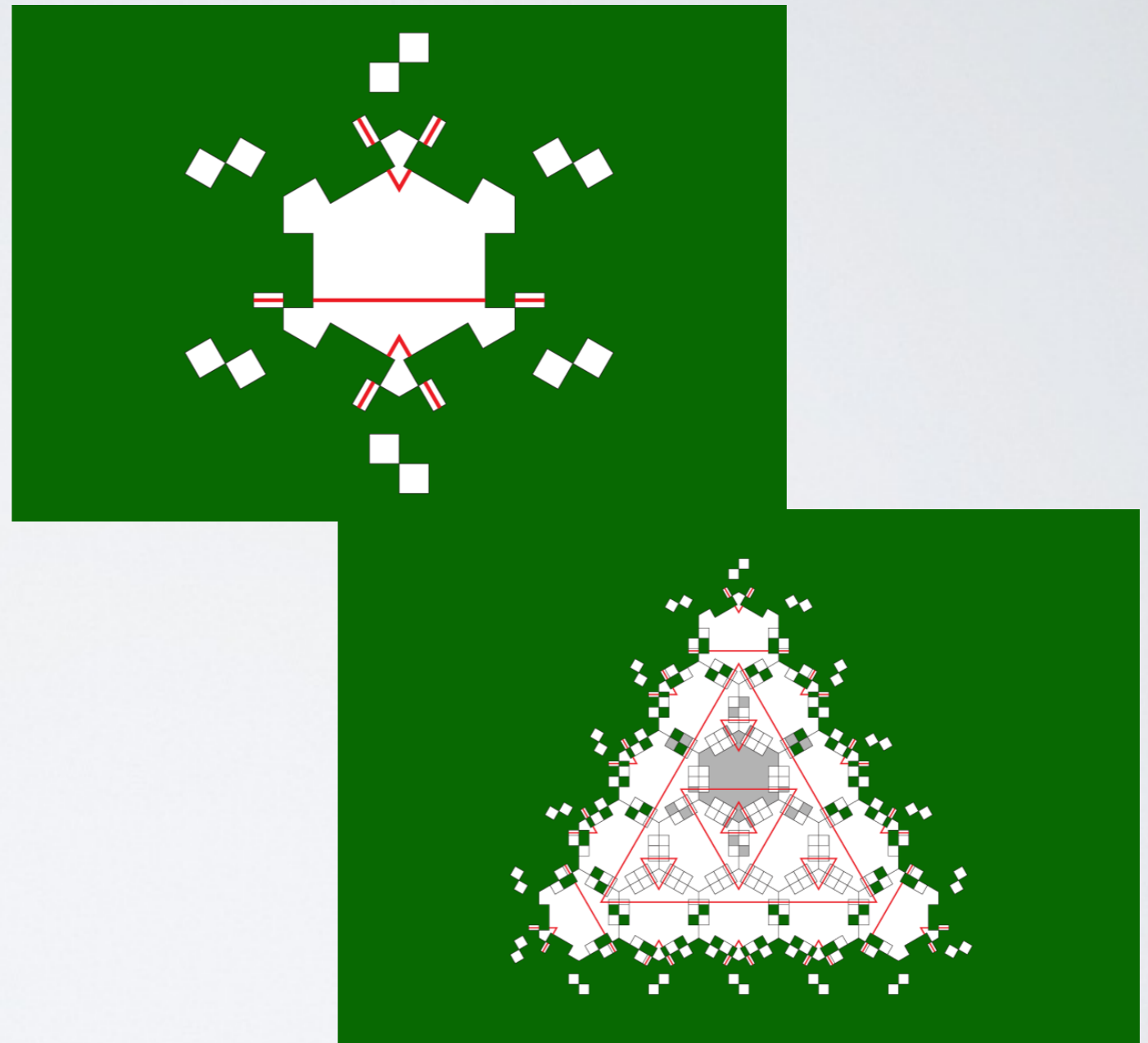

Pic: Edmund Harris

- Open question: Is there a single aperiodic connected 2D tile that makes gap-free tilings of the plane?

http://en.wikipedia.org/wiki/List_of_unsolved_problems_in_mathematics#Euclidean_geometry

But this is not (yet) magic dust

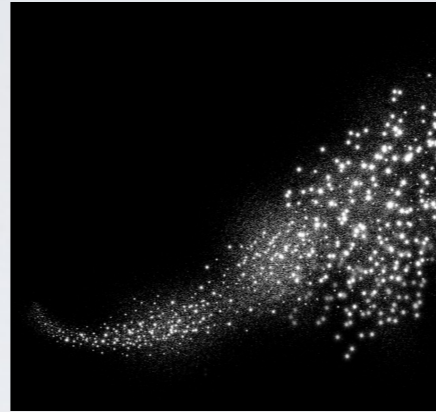

A harder challenge: one tile for all of tile self-assembly

- Simulating tile assembly systems is significantly trickier than plane (Wang) tiling systems
- We want to design a single rotatable, flipable tile that simulates any tile assembly system
- Problem 1:
- Strength τ glues on rotatable tiles => Argh! There's pumpable junk everywhere!
- So lets not use strength τ glues on The One.
- Maybe we could find an intrinsically universal square tile set with strength $< \tau$ glues?
 - No! Any such tile set with a finite seed can not leave the seed's bounding box
 - Lets try hexagons!

Low strength hexes simulate high-strength squares

- Strength 1 or 0 hexagon glues, simulating strength 2, 1 or 0 square glues

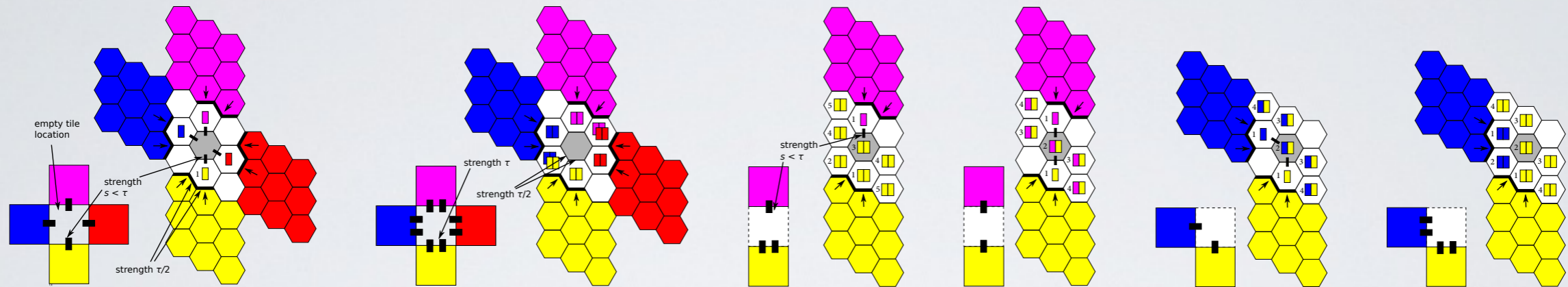

- Then we can simulate a set of low-strength hexagons with a single rotatable polygon
 - Bumps and dents to stop incorrect orientations and incorrect bindings
 - Glues are carefully rearranged on the polygon to allow “self seeding”
 - ...
 - Many details omitted!

Construction overview

Tile assembly system T



Hexagonal tile assembly system that simulates T (using low-strength glues)



One polygon that simulates T

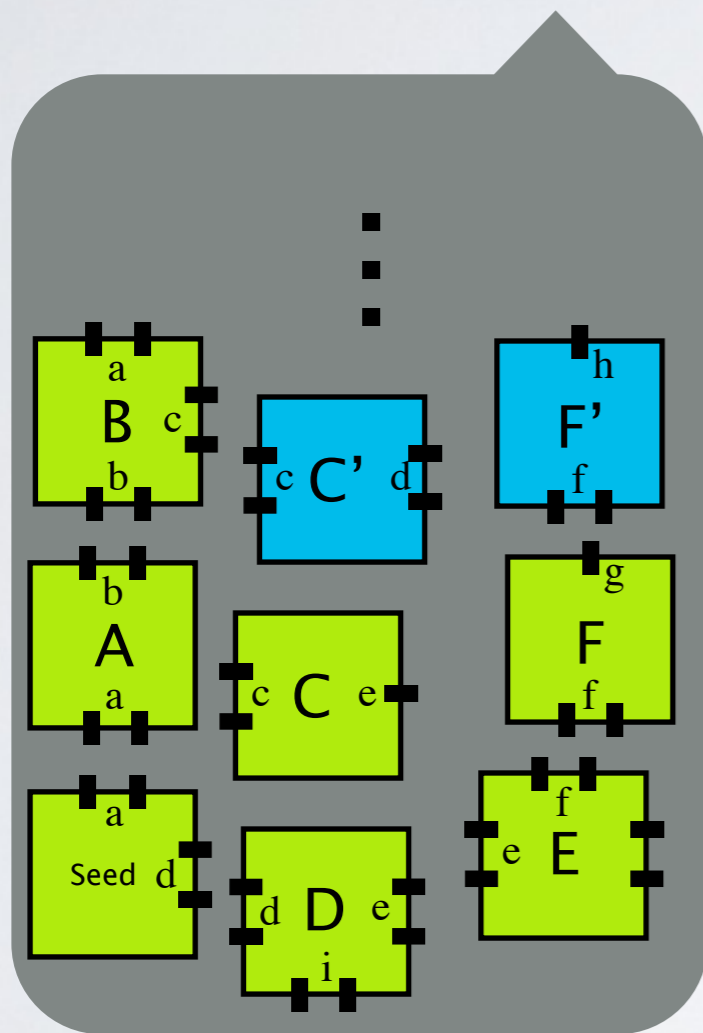

Tile set

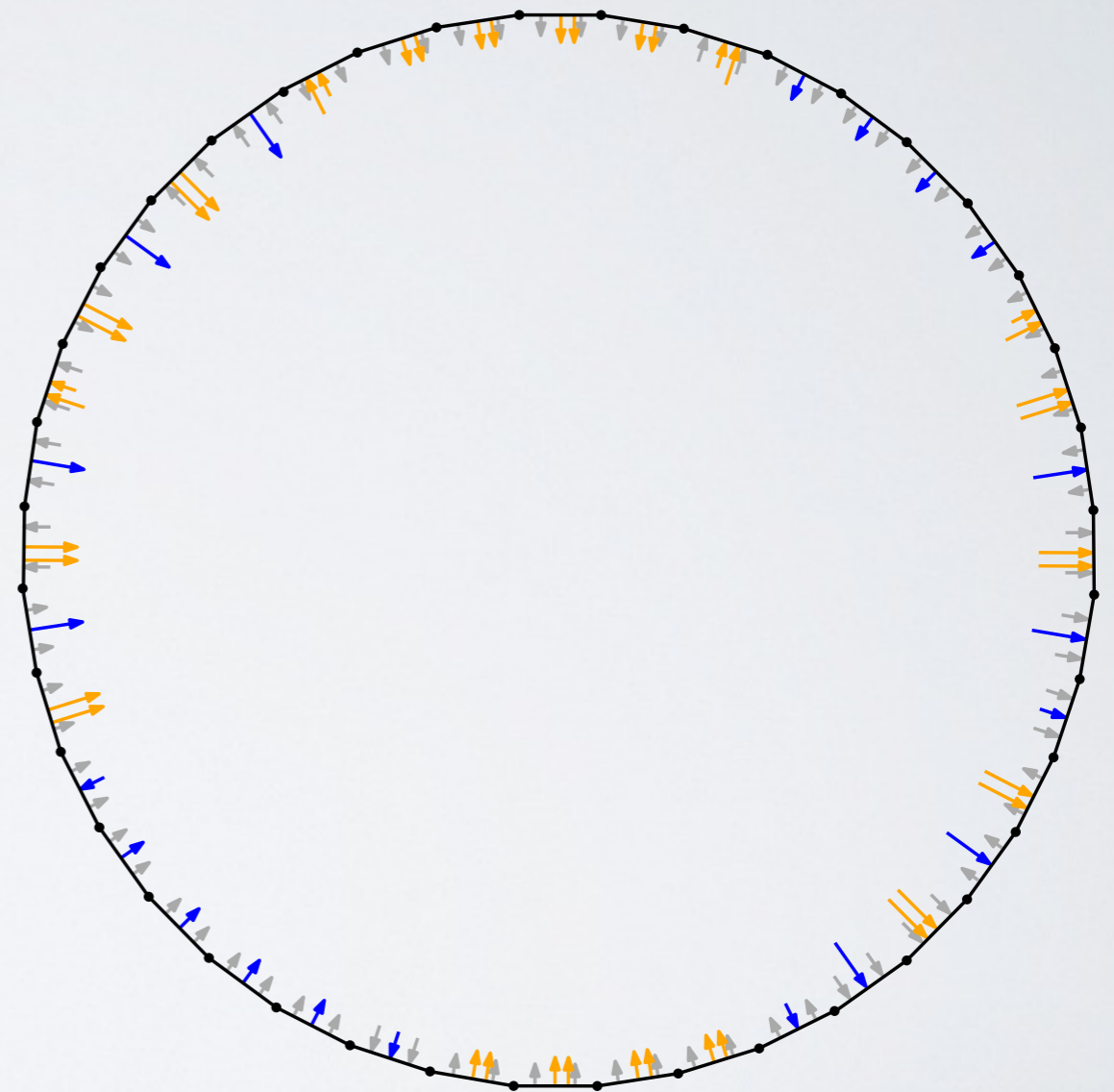

The one

To use The One, simply apply a sequence of tile assembly system simulations:

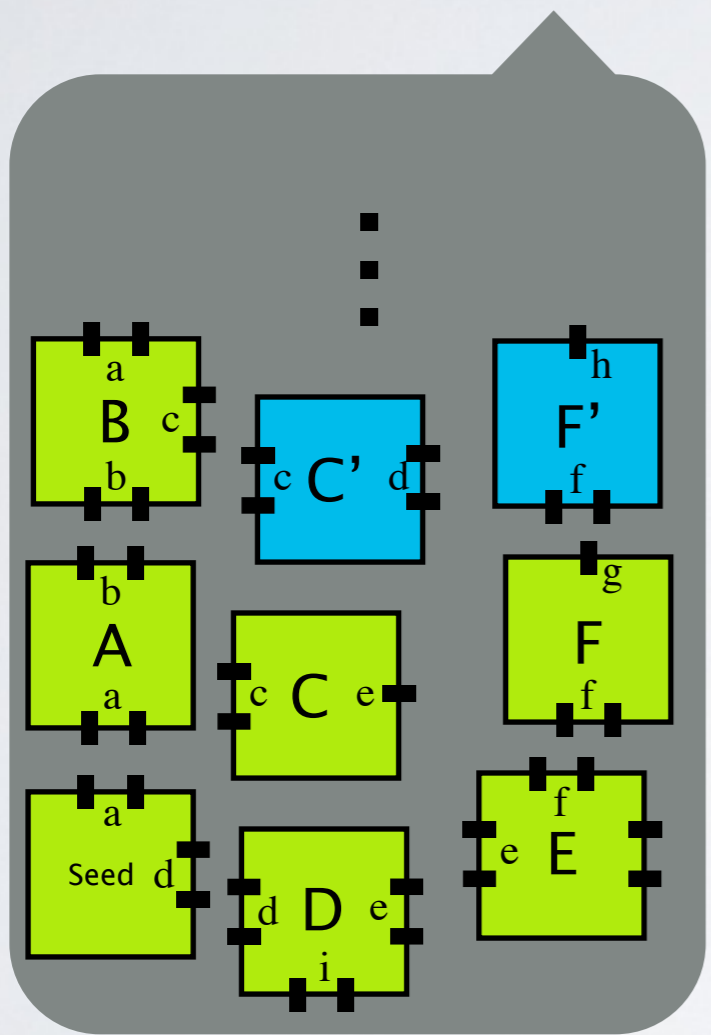
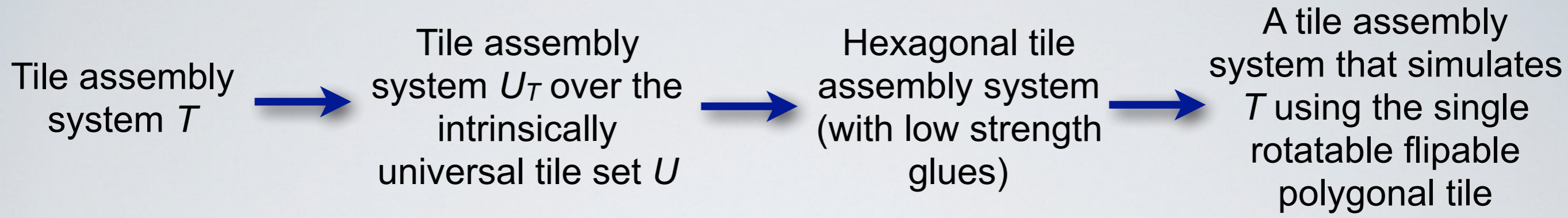

Intrinsically universal tile set

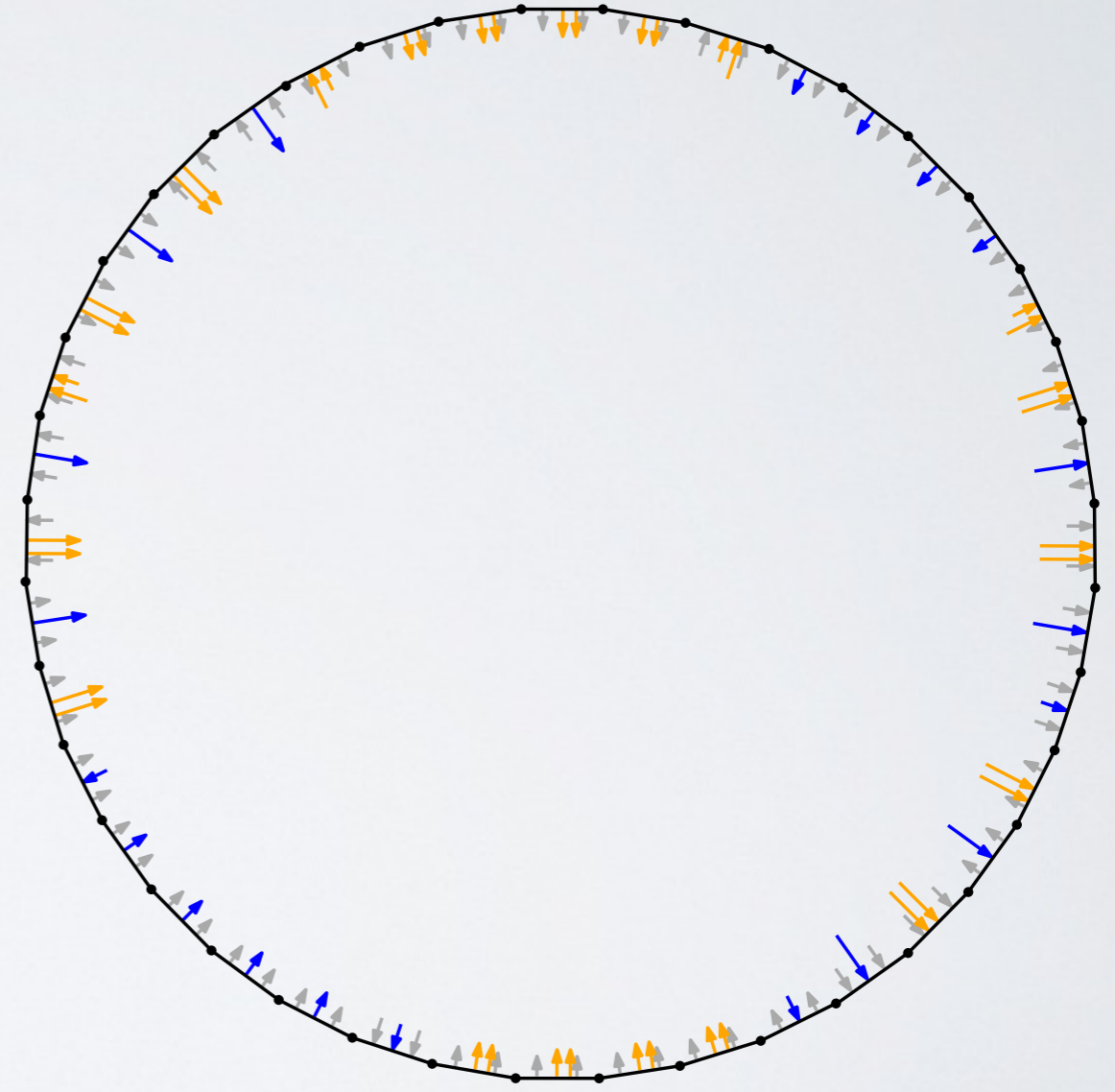

The one

To use The One, simply apply a sequence of tile assembly system simulations:

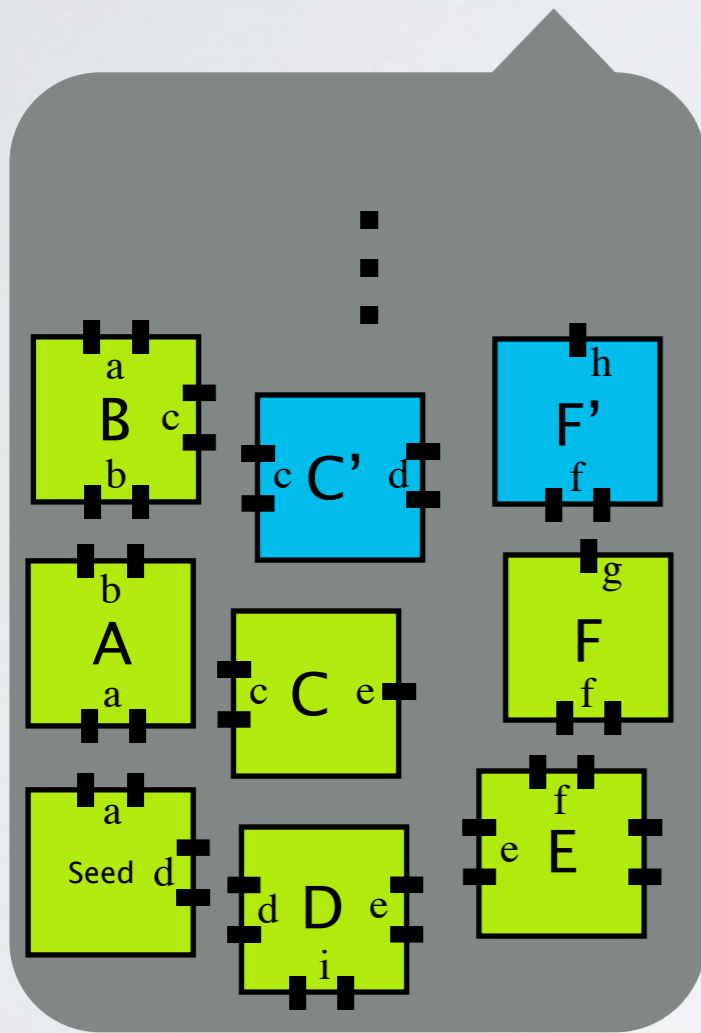
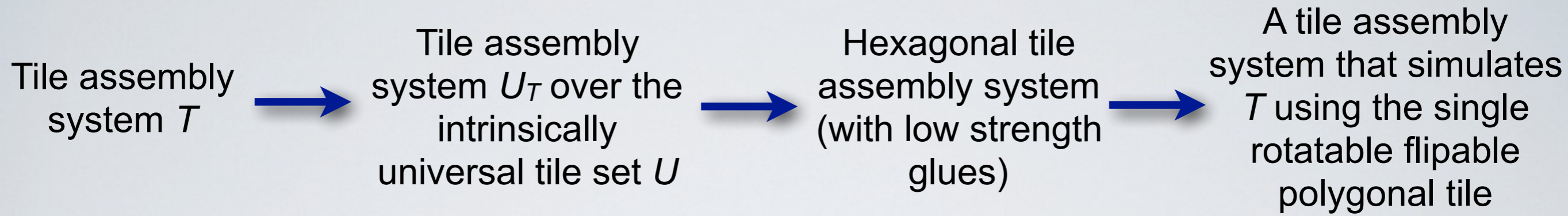

Intrinsically universal tile set



The one

One tile to simulate them all

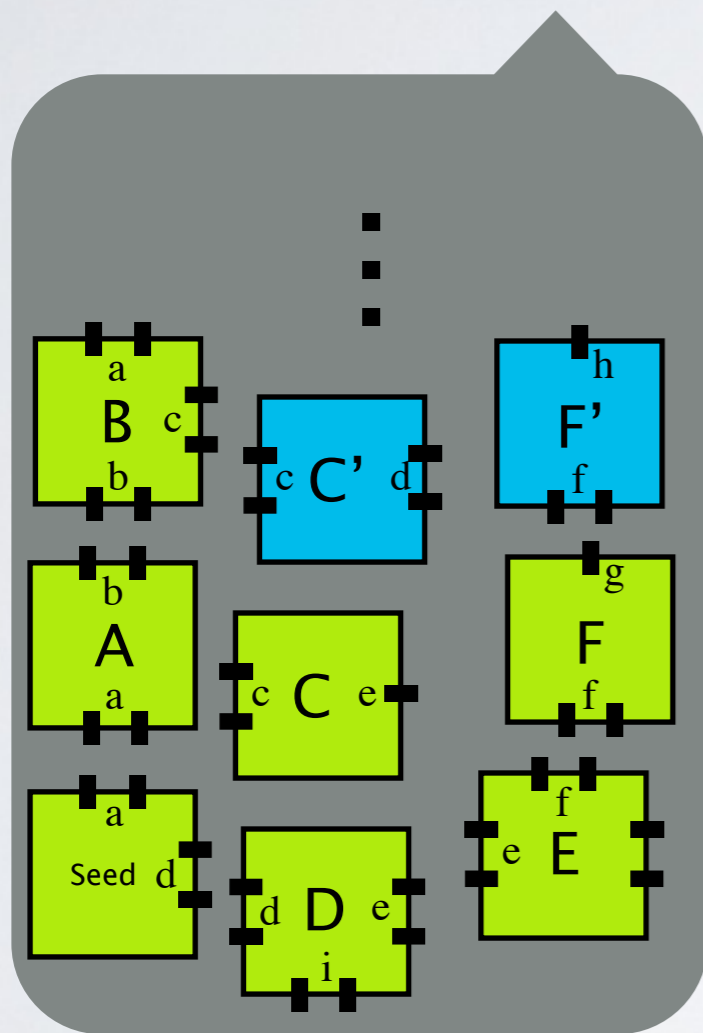

Intrinsically
universal tile set



The one

One tile to simulate them all

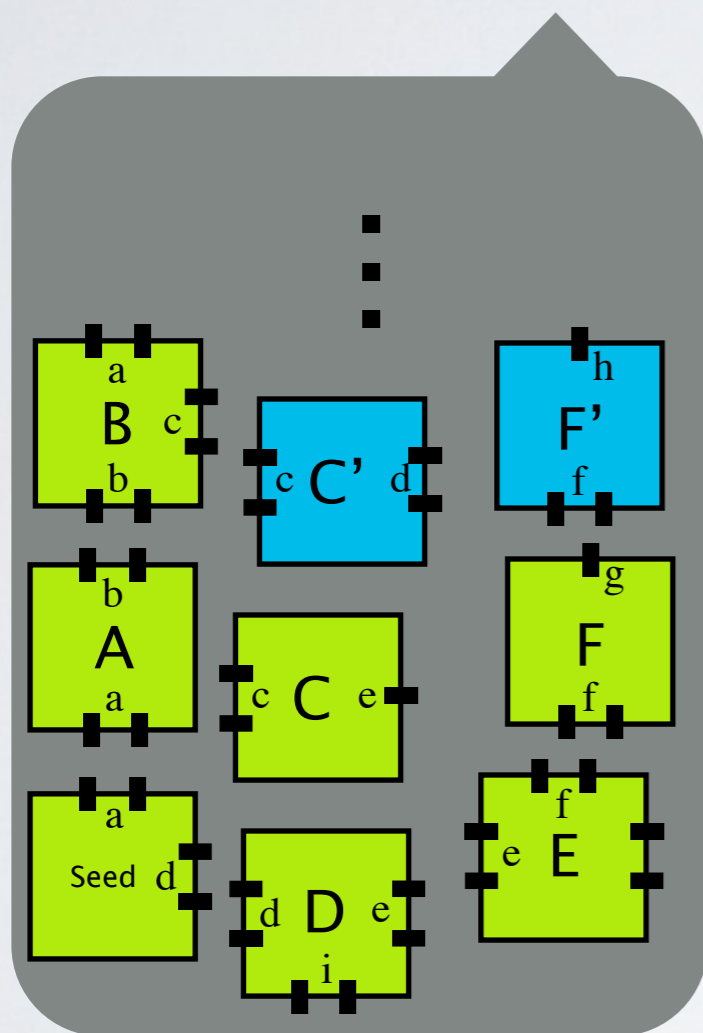

Intrinsically
universal tile set



The one

Magic dust

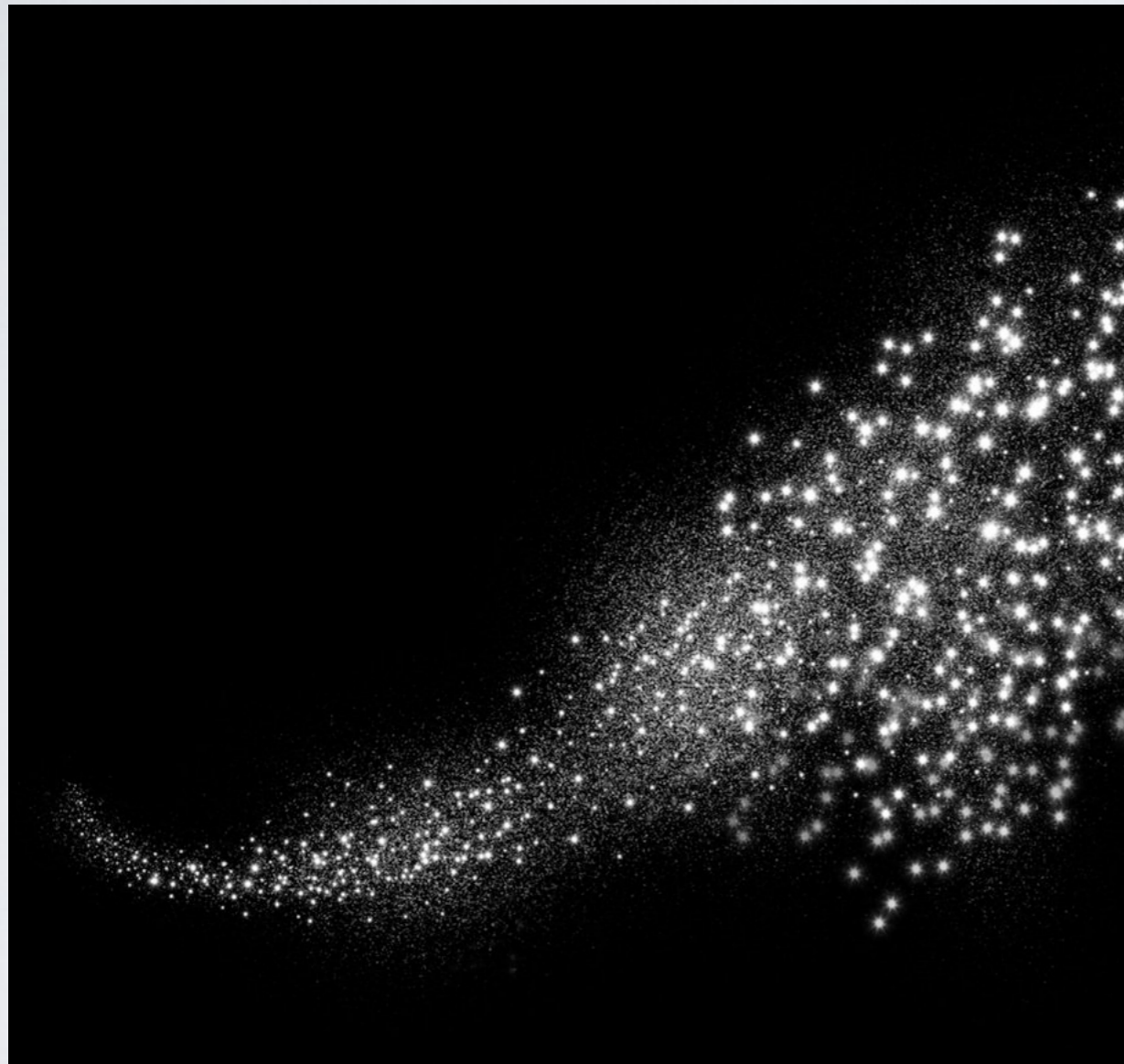

<http://nighthawk101stock.deviantart.com/>

=

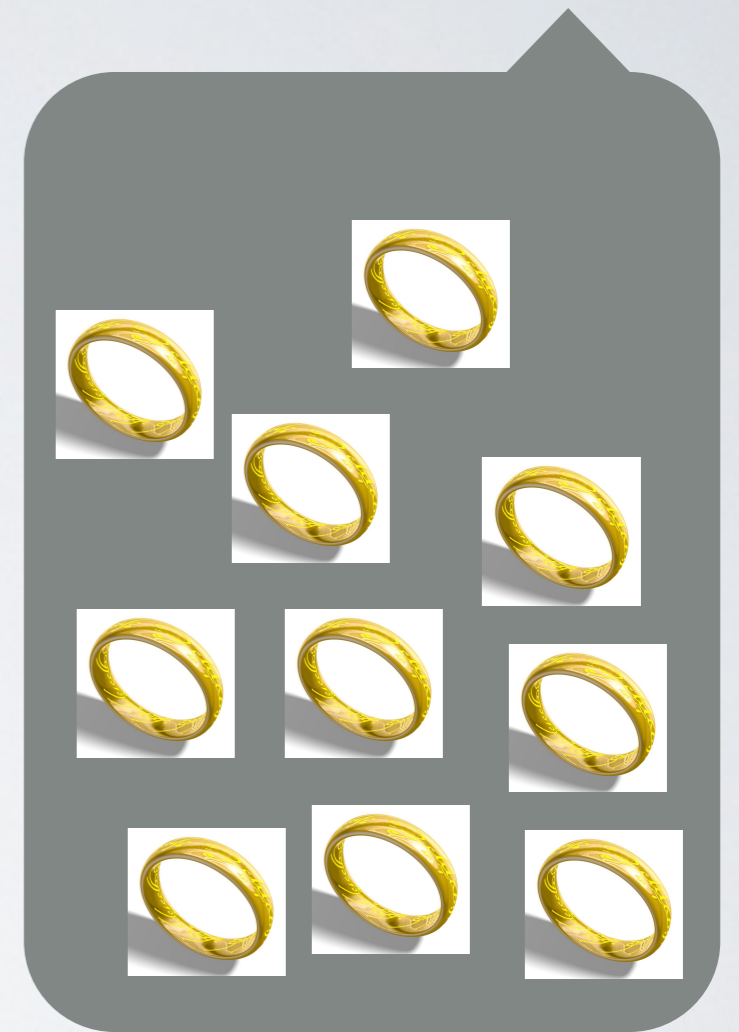

Our journey

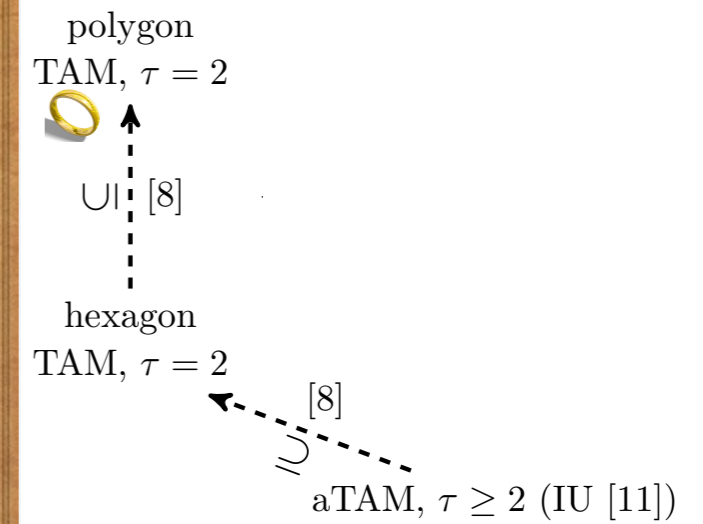

Our journey

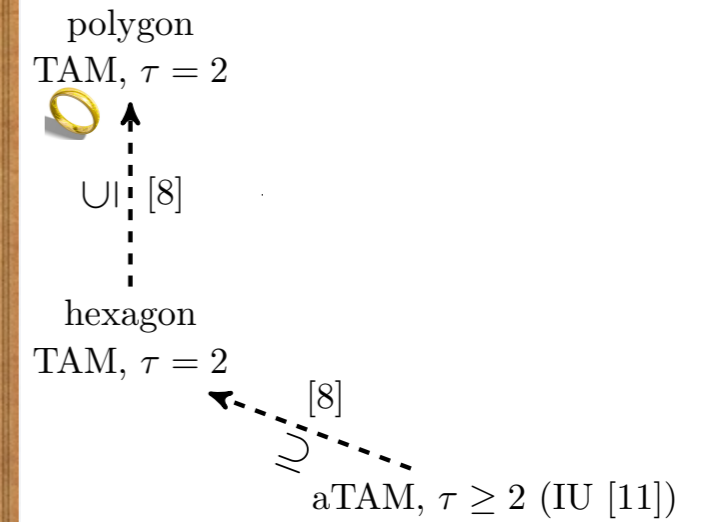

Our journey

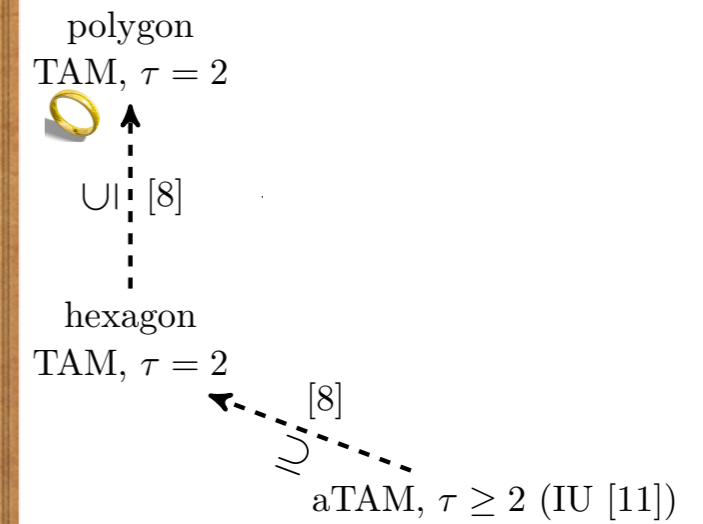

Temperature 1

Temperature 1 tile assembly

- Temperature 1 tile assembly systems:
 - Each glue has strength 0 or 1
 - Tile binds to an assembly if ≥ 1 glues match with strength = 1
 - Snakes on a plane

Temperature 1 tile assembly

- Temperature 1 tile assembly systems:
 - Each glue has strength 0 or 1
 - Tile binds to an assembly if ≥ 1 glues match with strength = 1
 - Snakes on a plane

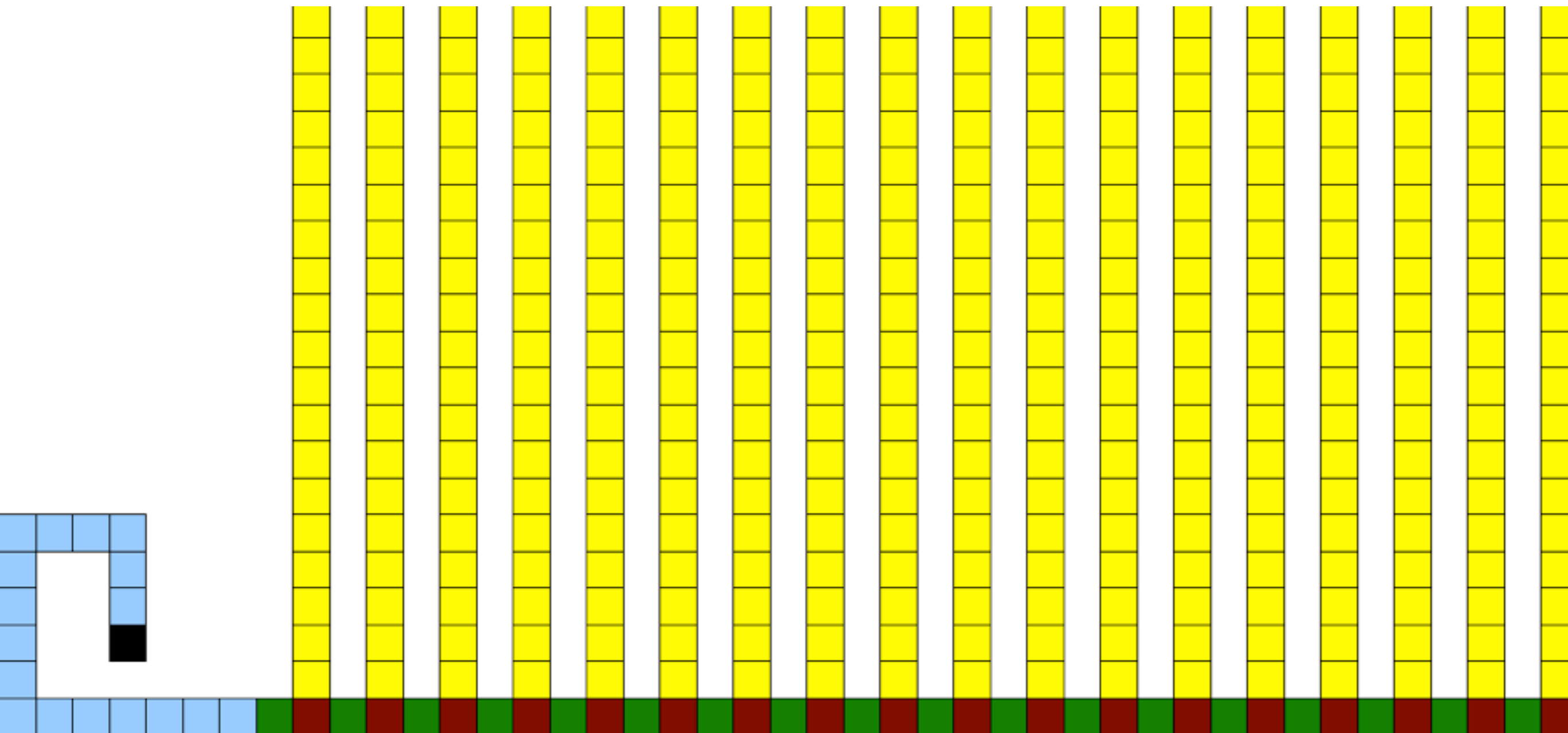

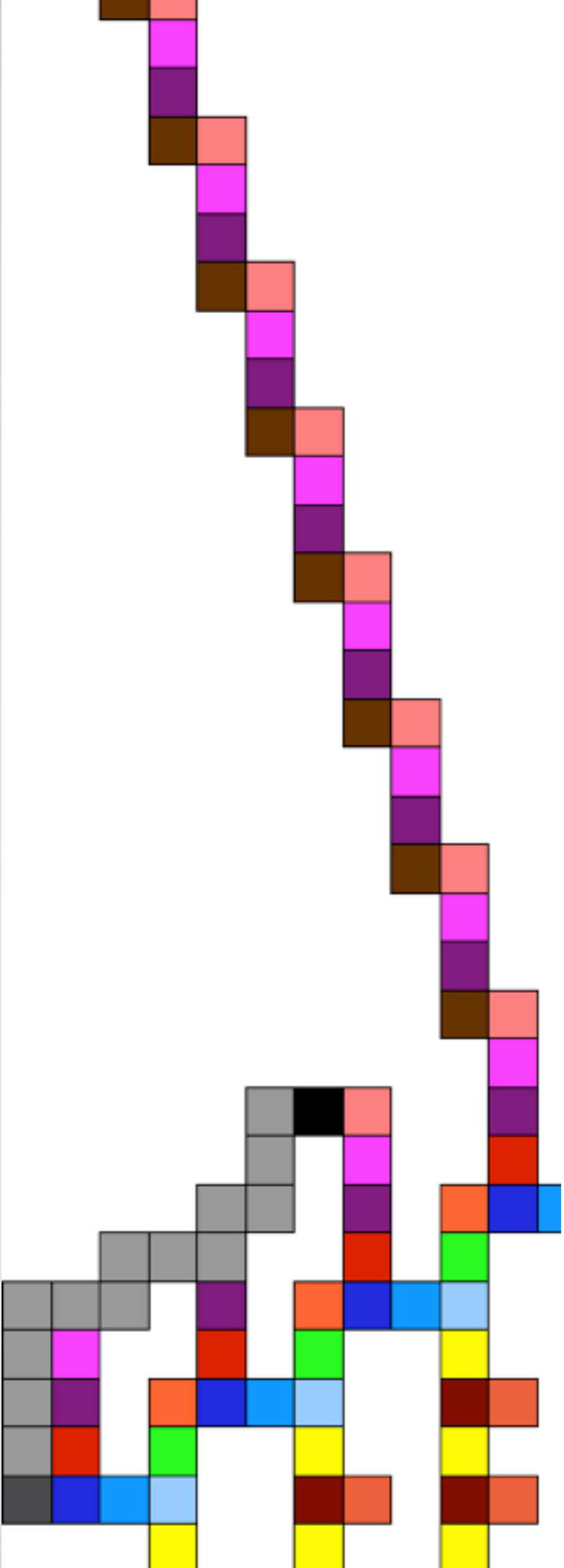

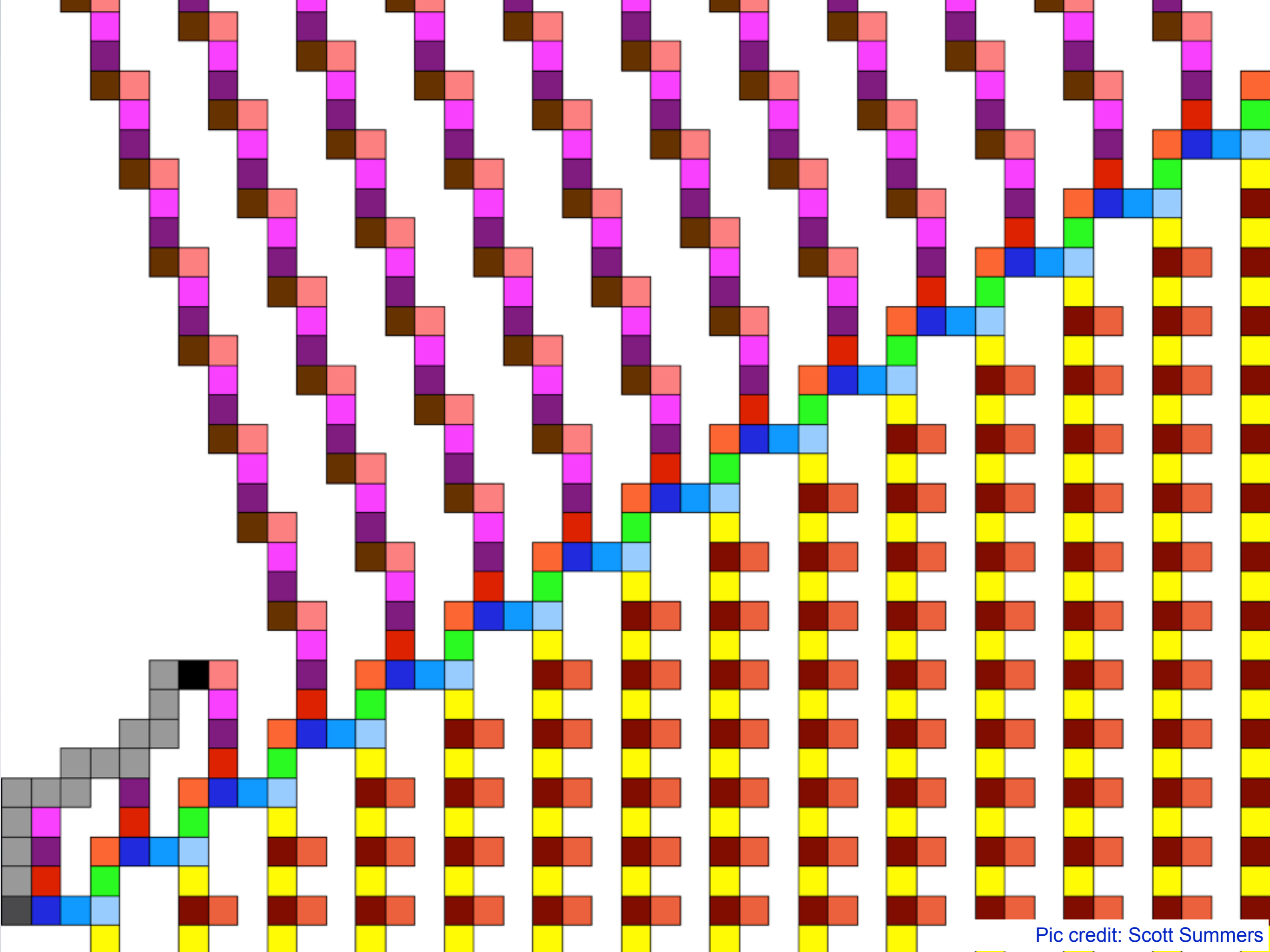

Pic credit: Scott Summers

Is temperature 1 computationally weak?

- “Cooperation is the key to computing with self-assembly”
 - Scott Summers. Yesterday.

Is temperature 1 computationally weak?

- “Cooperation is the key to computing with self-assembly”
 - Scott Summers. Yesterday.

- “Cooperation is* the key to computing with self-assembly”
 - Scott Summers. Yesterday.

Is temperature 1 computationally weak?

- It has been conjectured (since 2000) that temperature 1 systems are “computationally weak” [Rothemund, Winfree. STOC 2000](#)
- Some negative results:
 - Temperature 1 systems that build **fully connected** $n \times n$ squares require at least n^2 tile types [Rothemund, Winfree. STOC 2000](#)
 - **Pumpable** temperature 1 systems produce only periodic structures [Doty, Patitz, Summers. TCS 2011](#)
 - Temperature 1 with **no mismatches** require $2n-1$ tile types to assemble an $n \times n$ square [Manuch, Stacho, Stoll. J Comp. Bio. 2010](#)
- Positive results:
 - 3D deterministic temperature 1 simulates Turing machines [Cook, Fu Schweller. SODA 2011](#)
 - 2D temperature 1 simulates Turing machine, but with some error [Cook, Fu Schweller. SODA 2011](#)
- Plus very recent negative and positive results by Pierre-Etienne Meunier
- It remains open whether temperature 1 (aka noncooperative) tile assembly systems can simulate Turing machines deterministically in 2D
- But can temperature 1 aTAM systems **do tile assembly**? I.e. can they simulate cooperative tile assembly?
- No! [Meunier, Patitz, Summers, Theyssier, Winslow, Woods. SODA 2014](#)

Temperature 1 is not IU for the aTAM

- We will show that no temperature 1 system simulates the following simple temperature 2 system

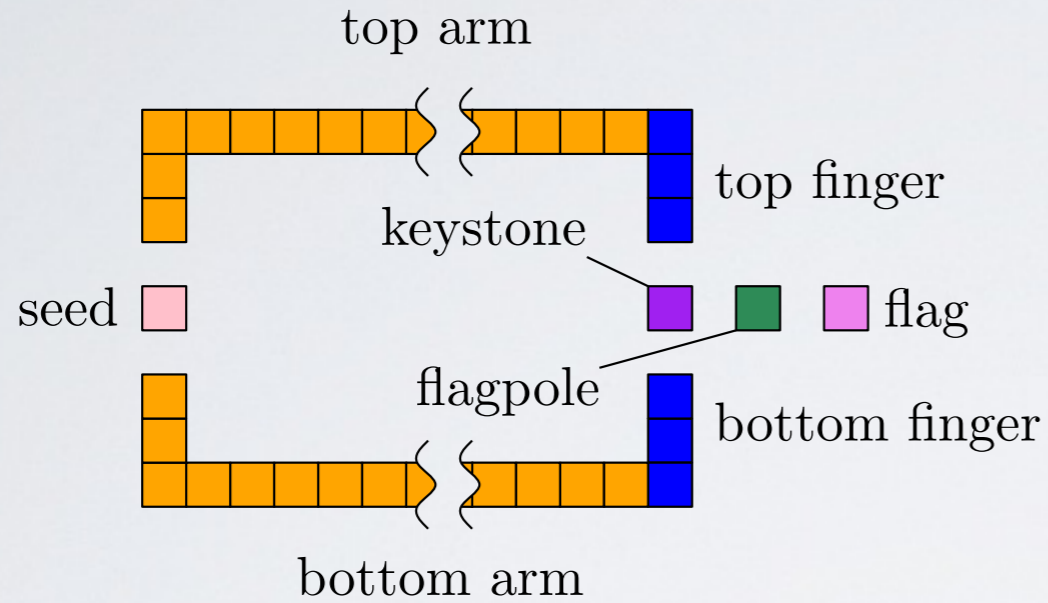

(a)

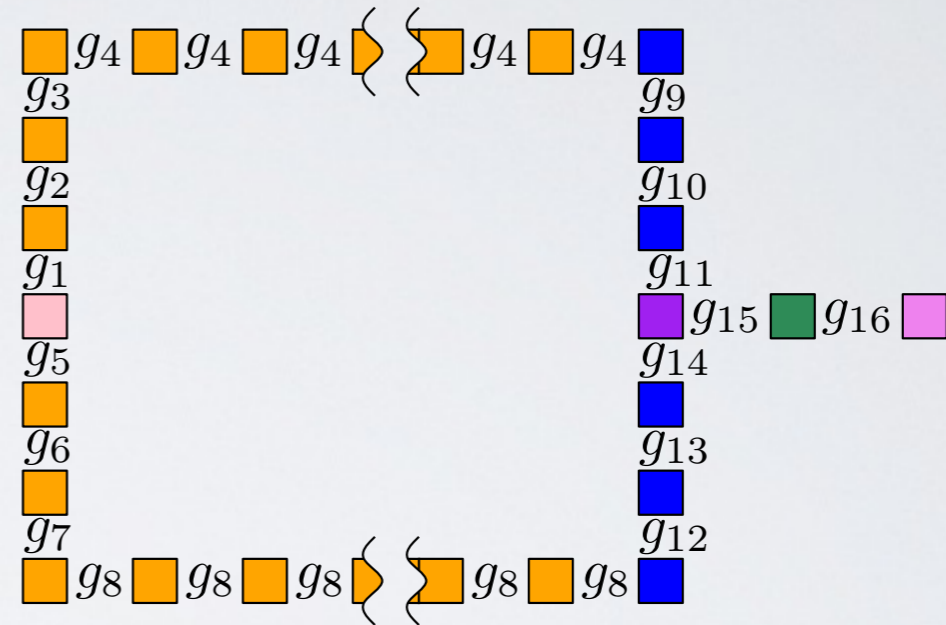

(b)

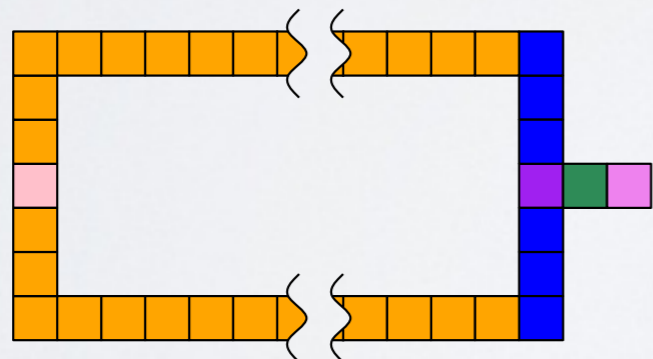

(c)

Equal arm lengths

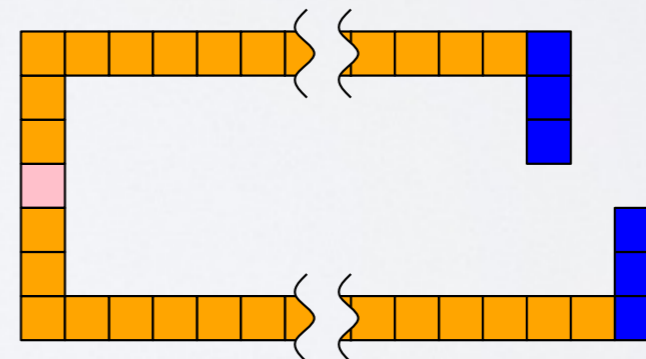

(d)

Unequal arm lengths

Temperature 1 is not IU for the aTAM

- First we prove a simple and general pumping lemma for tile assembly at any temperature (the window movie lemma)

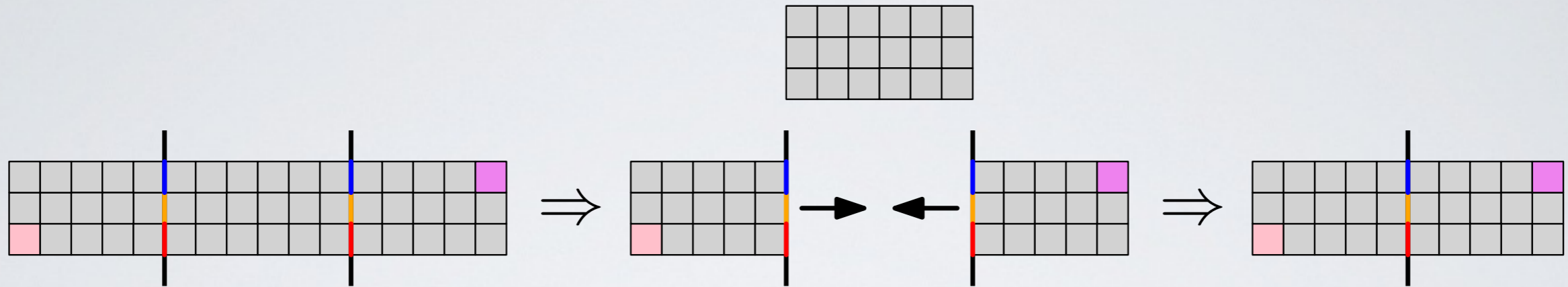

- We then use this pumping lemma to “fool” any claimed temperature 1 simulator into exposing its inability to simulate cooperation

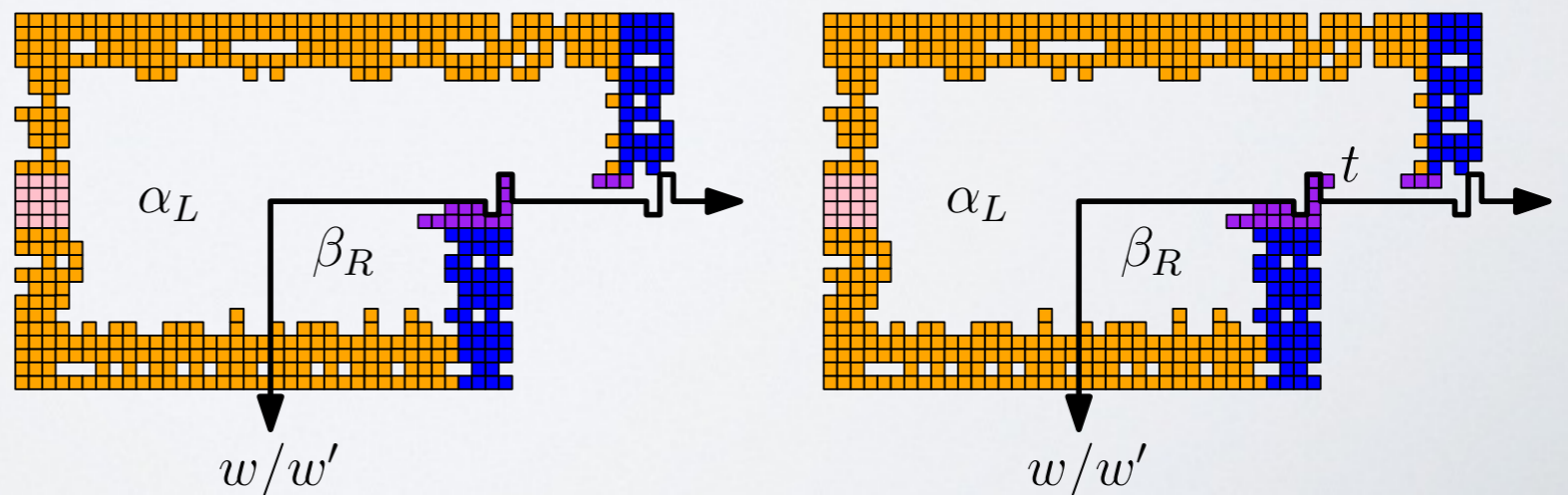
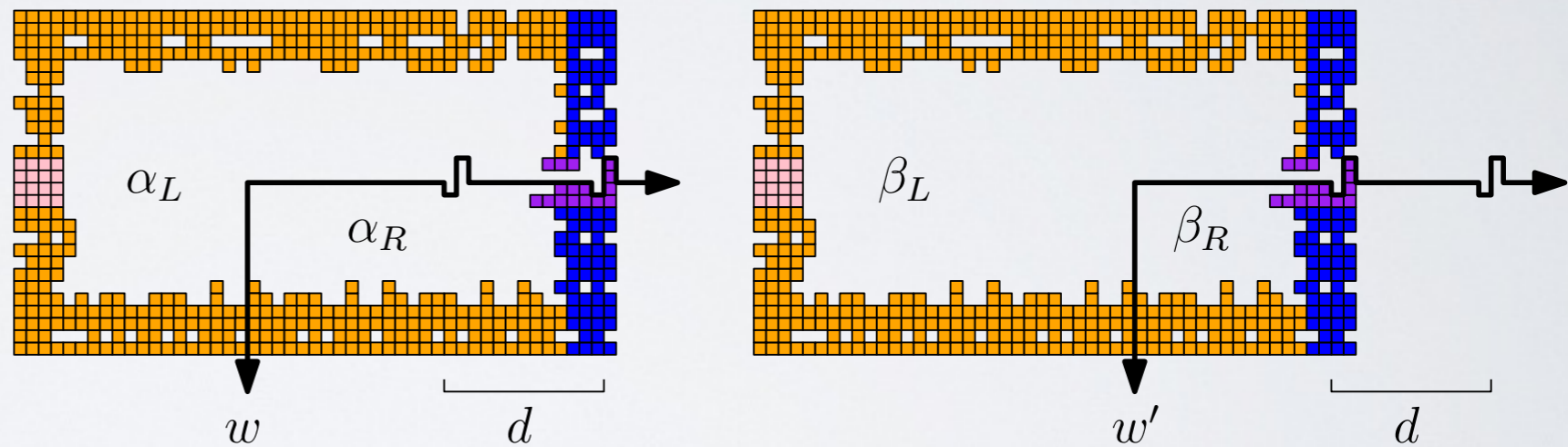

Temperature 1 is not IU for the aTAM

- There are simple temperature 2 systems that can not be simulated by any temperature 1 system Meunier, Patitz, Summers, Theyssier, Winslow, Woods. SODA 2014
- First fully-general negative result on temperature 1 (no restrictions on the model)
- This negative result holds in 2D and 3D
- Recall: Deterministic 3D temperature 1 systems can simulate Turing machines! Cook, Fu, Schweller. SODA 2011
- So these Turing-universal (powerful!) tile assembly systems can not simulate tile assembly
- **Turing universal algorithmic behaviour in self-assembly provably does not imply the ability to simulate arbitrary algorithmic self-assembly processes**
- **Temp 1 3D can compute, but can't handle geometry**
- We walked into Mordor, and survived

Our journey

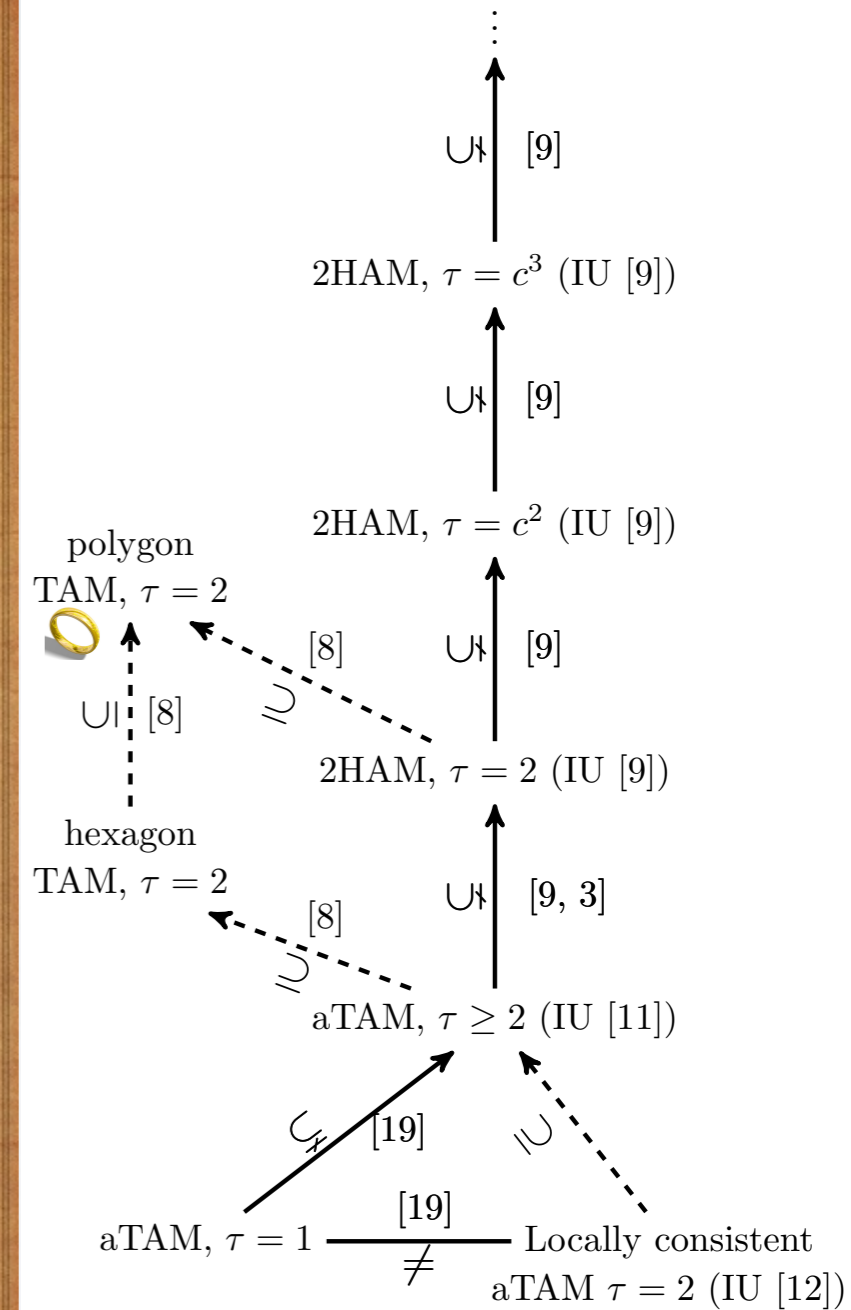

Conclusions

- 1. There is an intrinsically universal tile set
- 2. There is a single rotatable polygon that can simulate any tile assembly system, or Turing machine
- 3. There is an aperiodic rotatable polygonal tile
- 4. Intrinsic universality can be used to separate, and classify, the power of self-assembly systems:
 - Temperature 1 can not simulate temperature 2 and above
 - Infinite set, of infinite hierarchies of hierarchical self-assembly systems (2HAM)
 - There are many other cool results that I have not mentioned

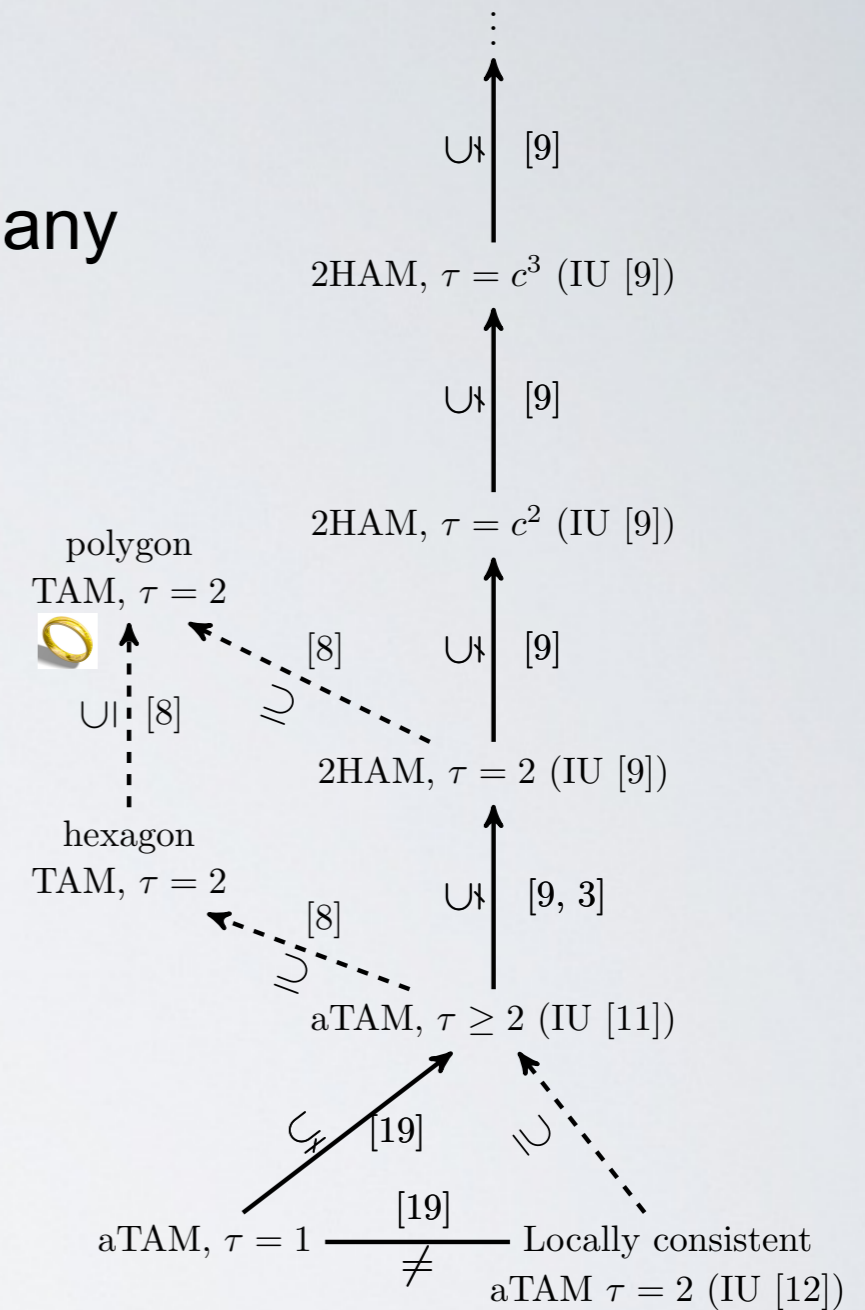

Related results

- Other cool results that I have not mentioned:
 - Simulations between tile assembly and CA
 Hendricks, Patitz, MCU, 2013
 - Two-handed 3D tile set is IU for the 2D Signal-Passing tile assembly model
 Hendricks, Padilla, Patitz and Rogers, DNA, 2013
 - 3D Temperature 1 can simulate 2D Temperature 1
 Meunier, Patitz, Summers, Theyssier, Winslow, Woods. SODA 2014
 - The restricted “locally consistent” tile assembly systems are intrinsically universal
 Doty, Lutz, Patitz, Summers, Woods, STACS 2010
 - Doubles and Negatives are Positive (in Self-Assembly)
 Hendricks, Patitz, Rogers. UCNC 2014
 - The Power of Duples (in Self-Assembly): It's Not So Hip To Be Square,
 Hendricks, Patitz, Rogers, Summers. COCOON 2014
 - Scaled tree fractals do not strictly self-assemble
 Summers, Furcy, Barth, Totzke, Summers. UCNC 2014

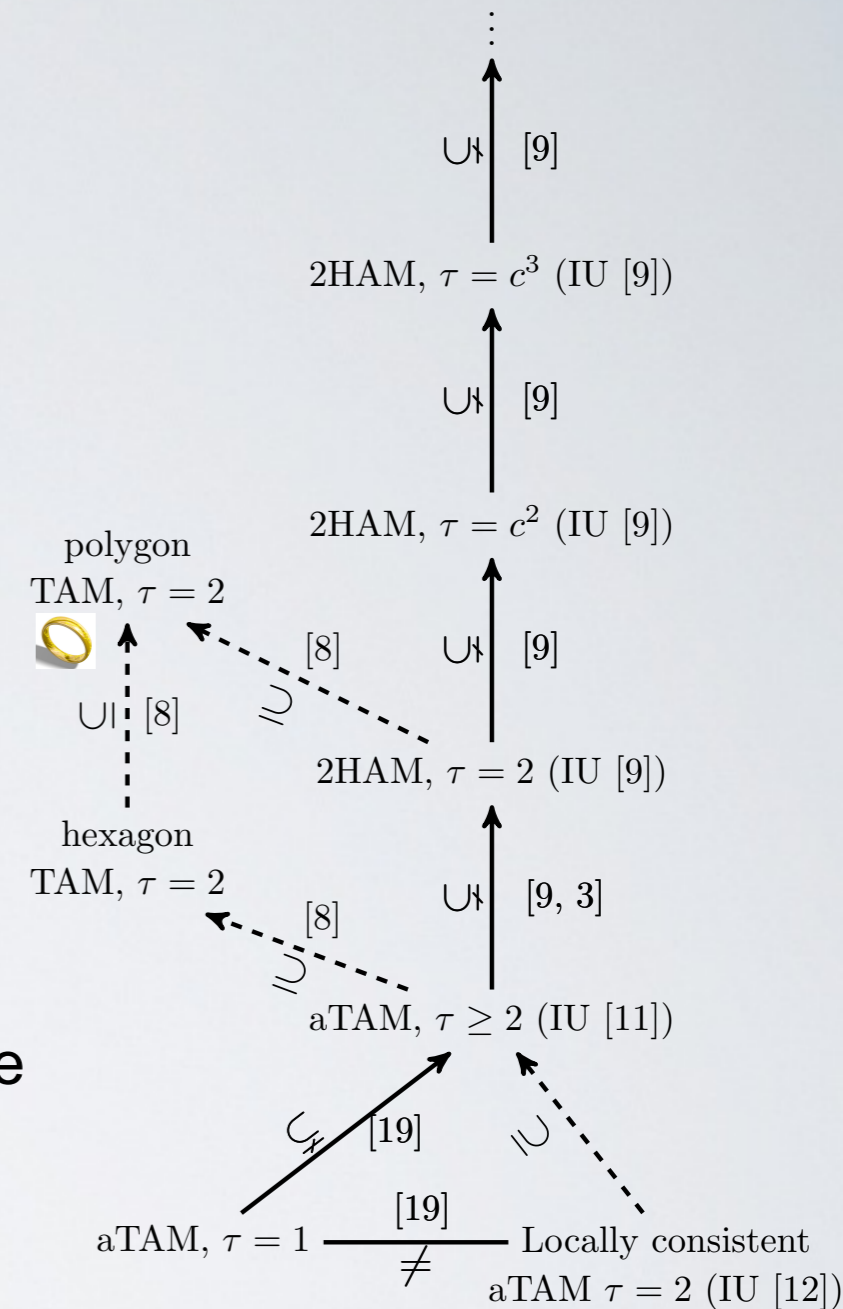

Open questions

- 1. Is your favourite model intrinsically universal?
 - hexagonal tile assembly model, polygonal tile assembly model, nubots, signal-passing tile assembly model
- 2. Can we show that no 2D temperature 1 system can deterministically (correctly) simulate temperature 2 “zig-zag” tile assembly systems?
- And many others!
- Come to the workshop for more!

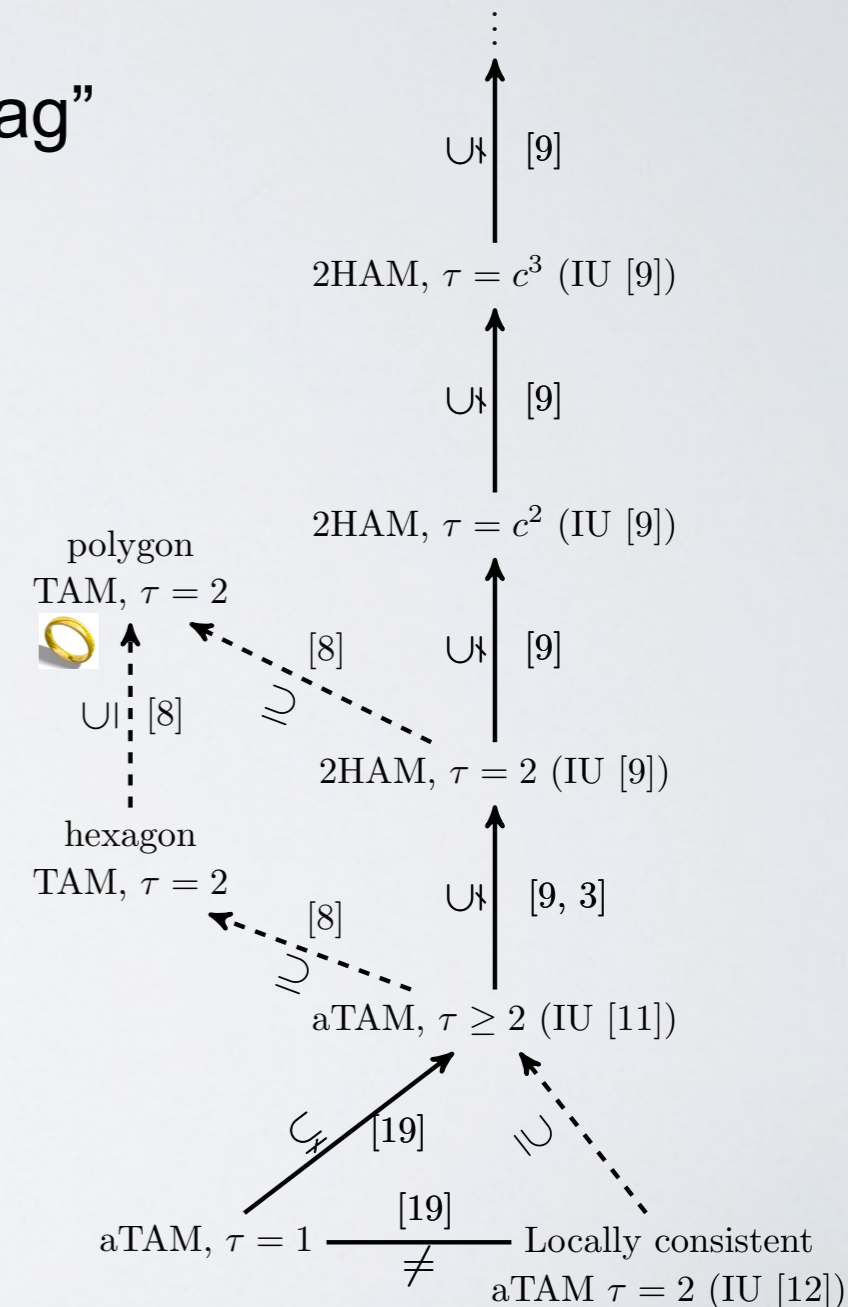

Thanks!

The tile assembly model is intrinsically universal. Doty, Lutz, Patitz, Schweller, Summers, Woods. FOCS 2012



Jack Lutz Matthew Patitz Dave Doty Scott Summers Robert Schweller



Pierre-Étienne Meunier



Guillaume Theyssier



Andrew Winslow

Intrinsic universality in tile self-assembly requires cooperation. Meunier, Patitz, Summers, Theyssier, Winslow, Woods. SODA 2014



Erik Demaine



Martin Demaine

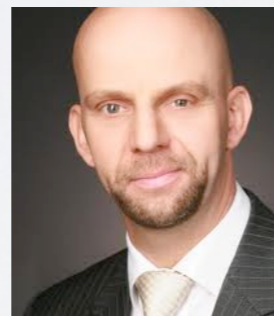

Sándor Fekete

One Tile to Rule Them All: Simulating Any Turing Machine, Tile Assembly System, or Tiling System with One Rotatable Puzzle Piece. Demaine, Demaine, Fekete, Patitz, Schweller, Winslow, Woods. ICALP 2014.

- Who paid? NSF: Molecular programming project grant 0832824, CCF-1219274 and CCF-1162589; Science Foundation Ireland, Junta de Andalucia Spain, Canada.
- Special thanks: Erik Winfree, Paul Rothemund, Matthew Cook, Turlough Neary, Niall Murphy, David Soloveichik, Shuki Bruck. Also the members of Erik Winfree's, Paul Rothemund's and Shuki Bruck's groups at Caltech



f i n ?

Our journey must continue...

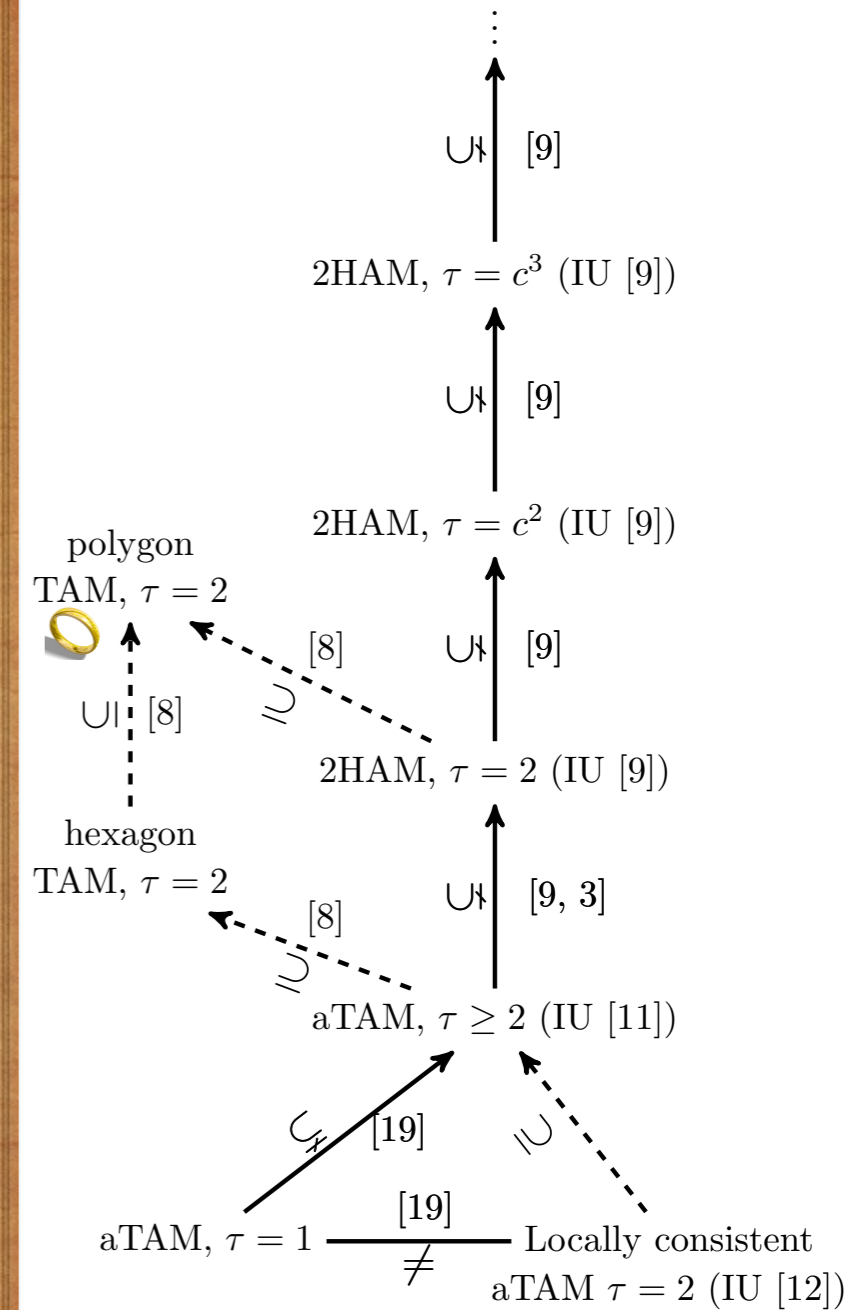

Temperature 1